



Evaluation Report CCMC 13329-R FlexGard Aspire™, PermaGuard™, PermaGard™, Dri-Shield™ II, Xmark Housewrap, Grip-Rite® Housewrap, NovaWrap™ Aspire™ - Air Barrier Material

MasterFormat: 07 27 09.02

Evaluation issued: 2008-08-25

Re-evaluated: 2018-01-17

1. Opinion

It is the opinion of the Canadian Construction Materials Centre (CCMC) that “FlexGard Aspire™, PermaGuard™, PermaGard™, Dri-Shield™ II, Xmark Housewrap, Grip-Rite® Housewrap, NovaWrap™ Aspire™ - Air Barrier Material,” when used as an air barrier material in accordance with the conditions and limitations stated in Section 3 of this Report, complies with the National Building Code (NBC) of Canada 2015:

- Clause 1.2.1.1.(1)(a) of Division A, as an acceptable solution from Division B:
 - Sentence 9.36.2.10.(1), Construction of Air Barrier Details
- Clause 1.2.1.1.(1)(b) of Division A, as an alternative solution that achieves at least the minimum level of performance required by Division B in the areas defined by the objectives and functional statements attributed to the following applicable acceptable solutions:
 - Article 9.25.3.2., Air Barrier System Properties

This opinion is based on CCMC’s evaluation of the technical evidence in Section 4 provided by the Report Holder.

Ruling No. 09-32-231 (13329-R), authorizing the use of this product in Ontario, subject to the terms and conditions contained in the Ruling, was made by the Minister of Municipal Affairs and Housing on 2009-12-02 (revised on 2012-10-11) pursuant to s.29 of the *Building Code Act*, 1992 (see Ruling for terms and conditions). This Ruling is subject to periodic revisions and updates.

2. Description

This report addresses the performance of the products as an air barrier material within the Intertape Polymer Corporation-specified “FlexGard® Aspire™, PermaGuard™, PermaGard™, Dri-Shield™ II, Xmark Housewrap, Grip-Rite® Housewrap, NovaWrap™ Aspire™” air barrier system. The air barrier system has not been evaluated, but is covered in Appendix A of this Report for the convenience of building officials and designers.

If the products are installed as part of the designated air barrier system, it will serve a dual function in the wall assembly. Use of the products as a sheathing membrane to control incidental water infiltration behind cladding is covered under a separate CCMC Evaluation Report (see CCMC 13292-R).

The products are produced from spun-bonded polypropylene, non-woven fabric with a monolithic polymer coating on one side. The products resist the passage of water, but permit the passage of water vapour.

The products are 0.43 mm thick and are available in various colours, including a standard teal. They are available in rolls ranging in widths from 0.91 m to 3.05 m and in lengths from 7.62 m to 2 800 m.

3. Conditions and Limitations

CCMC’s compliance opinion in Section 1 is bound by “FlexGard Aspire™, PermaGuard™, PermaGard™, Dri-Shield™ II, Xmark Housewrap, Grip-Rite® Housewrap, NovaWrap™ Aspire™ - Air Barrier Material” being used in accordance with the conditions and limitations set out below.

- The products have demonstrated a sufficiently low air permeance equivalent to the materials outlined in Table A-9.25.5.1.(1), Air and Vapour Permeance Values, and Sentence 9.36.2.10.(1) of Division B of the NBC 2015 to be the principal plane of airtightness in an air barrier system.
- Generally, when the products are installed as part of the airtight element of the proponent’s proprietary air barrier system, the vapour barrier only needs to comply with Sentences 9.25.4.2.(1) and (5), Vapour Barrier Materials, of Division B of the NBC 2015. In cases where another low water vapour permeance element has been installed in the wall assembly, Article 9.25.5.1., General (Properties and Position of Materials in the Building Envelope), of Division B of the NBC 2015 must apply.
- The products must be installed:
 - with the printed side facing outward and protected from exposure to ultraviolet (UV) radiation from the sun within 60 days;
 - with a minimum 10-mm air space between the sheathing membrane and the cladding, unless the cladding has been deemed not to require an air space (e.g., by CCMC or by building officials based on past cladding performance); and
 - according to Intertape Polymer Corp.’s “FlexGard Aspire®, PermaGuard™, PermaGard™, Dri-Shield™ II, Xmark Housewrap, Grip-Rite® Housewrap, NovaWrap™ Aspire™” Installation Manual (sheathing membrane, air barrier and header wrap). Examples of the installation details are presented as “Additional Information” in Appendix A.
- A concealed air space exceeding 25 mm in width must contain proper fire stopping in accordance with Subsection 9.10.16., Fire Blocks, of Division B of the NBC 2015.
- CCMC-evaluated sheathing tape in accordance with MasterFormat 07 25 20 must be used to seal all joints.
- The product must be clearly identified with the phrase “CCMC 13329-R.”

4. Technical Evidence

The Report Holder has submitted technical documentation for CCMC’s evaluation. Testing was conducted at laboratories recognized by CCMC. The corresponding technical evidence for this product is summarized below.

The durability assessment of “FlexGard Aspire®, PermaGuard™, PermaGard™, Dri-Shield™ II, Xmark Housewrap, Grip-Rite® Housewrap, NovaWrap™ Aspire™” is covered under CCMC 13292-R, and additional aging in CAN/ULC-S741-08, “Standard for Air Barrier Materials – Specification.”

4.1 Performance Requirements

Table 4.1.1 Results of Testing of the Performance Requirements for the Products

Test	Requirement	Result
Tested as per CAN/ULC-S741-08 with five 1-m ² membrane specimens and measured for air permeance at a minimum of six air pressure differentials (ΔP) between 0 and 300 Pa – Unconditioned (Prior to UV and Heat Aging).	Air leakage rate at 75 Pa ΔP (based on linear regression of 30 data points) ≤ 0.02 L/(s·m ²)	0.0036 L/(s·m ²)
Five 1-m ² membrane specimens tested and measured for air permeance at a minimum of six air pressure differentials (ΔP) between 0 and 300 Pa – Conditioned (After UV and Heat Aging).	Where less than 0.01 L/(s·m ²) for unconditioned specimens, the increase of the air leakage rate at 75 Pa ΔP for conditioned specimens ≤ 0.001 L/(s·m ²).	0.0046 L/(s·m ²) ⁽¹⁾
		0.001 L/(s·m ²) ⁽²⁾
Water Vapour Permeance (Infiltration Direction)	When less than 60 ng/(Pa·s·m ²), the location of the product installation is restricted by the requirements listed in Article 9.25.1.1. of Division B of the NBC 2015.	332 ng/(Pa·s·m ²)
Water Vapour Permeance (Exfiltration Direction)		373 ng/(Pa·s·m ²)

Notes to Table 4.1.1:

1. Test result (air leakage rate) for the conditioned specimens after UV and heat aging.
 2. Increase of the air leakage rate for conditioned specimens after UV and heat aging.
-

Report Holder

Intertape Polymer Corp.
50 Abbey Avenue
Truro, NS B2N 6W4

Telephone: 902-895-1686

Fax: 902-893-4790

E-mail: info@itape.com

Web site: www.intertapepolymer.com

Plant(s)

Truro, NS

Disclaimer

This Report is issued by the Canadian Construction Materials Centre, a program of NRC Construction at the National Research Council of Canada. The Report must be read in the context of the entire CCMC Registry of Product Evaluations, including, without limitation, the introduction therein which sets out important information concerning the interpretation and use of CCMC Evaluation Reports.

Readers must confirm that the Report is current and has not been withdrawn or superseded by a later issue. Please refer to http://www.nrc-cnrc.gc.ca/eng/solutions/advisory/ccmc_index.html, or contact the Canadian Construction Materials Centre, NRC Construction, National Research Council of Canada, 1200 Montreal Road, Ottawa, Ontario, K1A 0R6. Telephone 613-993-6189. Fax 613-952-0268.

NRC has evaluated the material, product, system or service described herein only for those characteristics stated herein. The information and opinions in this Report are directed to those who have the appropriate degree of experience to use and apply its contents. This Report is provided without representation, warranty, or guarantee of any kind, expressed, or implied, and the National Research Council of Canada (NRC) provides no endorsement for any evaluated material, product, system or service described herein. NRC accepts no responsibility whatsoever arising in any way from any and all use and reliance on the information contained in this Report. NRC is not undertaking to render professional or other services on behalf of any person or entity nor to perform any duty owed by any person or entity to another person or entity.

Date modified:

2018-01-17

Appendix A

Additional Information

An air barrier material as part of an air barrier system

CCMC has not evaluated the performance of the Intertape Polymer Corporation's "FlexGard Aspire[®], PermaGuard[™], PermaGard[™], Dri-Shield[™] II, Xmark Housewrap, Grip-Rite[®] Housewrap, NovaWrap[™] Aspire[™]" air barrier system as to its conformance with Article 9.25.3.2., Air Barrier System Properties, of Division B of the NBC 2015. However, CCMC's opinion is that an air barrier system using this material and installed in conformance with the details outlined below, as well as in Intertape Polymer Corp.'s Installation Manual should satisfy the requirements for continuity of the air barrier system in Articles 9.25.3.1., Required Barrier to Air Leakage, and 9.25.3.3., Continuity of the Air Barrier System, of Division B of the NBC 2015.

Discussion

Authorities having jurisdiction (AHJ) should be aware that this system differs from the typical air barrier approach, which uses a flexible membrane as the principal plane of airtightness. In the typical approach, the membrane (i.e. a polyethylene sheet) is normally sandwiched between two other materials so that it is not required to resist, on its own, the full force of indoor/outdoor pressure differences induced by stack effect, mechanical systems and, most importantly, wind.

In a system in which the membrane is applied to the outer surface of the wall sheathing, as it is in the proposed air barrier system, that membrane does not have continuous support against outward air pressure and must, therefore, have adequate strength to resist that pressure by spanning between points of support, such as its own fastening points or the points where strapping or cladding is fastened to the wall. CCMC's evaluation of this material does not include the evaluation of this strength or the strength of the continuity details. The AHJ must, therefore, determine whether the product's air barrier system, described herein, meets the intent of Sentence 9.25.3.2.(1) of Division B of the NBC 2015, as being an effective barrier for the proposed construction in the proposed geographical/climate area. For example, the AHJ may deem the proposed air barrier system adequate for buildings in urban areas, sheltered sites or areas of low wind, based on their experience, but inadequate in areas of high wind and exposed sites in rural or coastal areas.

An air barrier system checklist for the AHJ to consider is the following:

An air barrier system must:

- (i) have an acceptable low air leakage rate;
- (ii) be continuous;
- (iii) be durable;
- (iv) have sufficient strength to resist the anticipated air pressure load; and
- (iv) be buildable in the field.

Installation details

The product's material is applied over exterior wood-based wall sheathing material complying with the NBC 2015. It does not contribute to an air barrier system until it is joined to the other components that make up the air barrier system of the building. Intertape Polymer Corp.'s Installation Manual outlines how the product's material must be joined to the foundation wall, windows and doors, penetrations in the wall and the ceiling air barrier in order to form the system.

A successful air barrier system installation is predicated on sequencing during construction. Coordination is required during erection of framing and after completion of the air barrier system to ensure that no other trade breaches the integrity of the installed air barrier system.

The proposed air barrier system is defined as possessing the following features:

- (i) "FlexGard Aspire[®], PermaGuard[™], PermaGard[™], Dri-Shield[™] II, Xmark Housewrap, Grip-Rite[®] Housewrap, NovaWrap[™] Aspire[™]" material as the principal plane of airtightness;
- (ii) accessories, including: sealants and CCMC-evaluated sheathing tape to maintain continuity at junctions with penetrations in the wall assembly (i.e., windows, doors, pipes, ducts, electrical outlets, etc.) and in accordance with continuity details in the Intertape Polymer Corp.'s Installation Manual;
- (iii) durability, meeting UV- and heat-aging requirements; and

- (iv) exterior sheathing with specified fasteners and fastening schedule of the product for structural support against anticipated pressure loads.

The air barrier system is to be built in the field by informed builders and reviewed by building officials.

Figures 1 to 7 outline typical construction details on the installation of the product as an air barrier system in the field. See Intertape Polymer Corp.'s "FlexGard Aspire[®], PermaGuard[™], PermaGuard[™], Dri-Shield[™] II, Xmark Housewrap, Grip-Rite[®] Housewrap, NovaWrap[™] Aspire[™] - Air Barrier Material" Installation Manual for additional details.

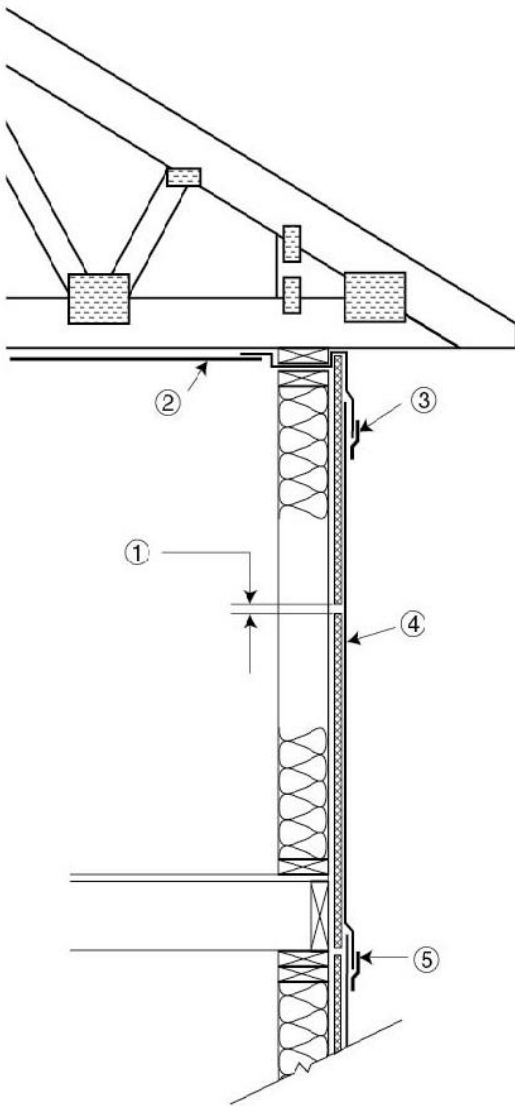

Figure 1. Exterior wall cross-section of the product – top wall/ceiling continuity:

- 1. wood-based sheathing installed with open horizontal gap**
- 2. ceiling air/vapour barrier**
- 3. CCMC-evaluated sheathing tape**
- 4. proprietary air barrier material**
- 5. typical overlap of 100 mm of the proprietary air barrier material and tape**

All horizontal joints in the material must be overlapped 100 mm and taped with CCMC-evaluated sheathing tape. To maintain continuity of the plane of airtightness, the material must be sealed to the roof by using an appropriate transition membrane. The material should be secured underneath the transition membrane to ensure proper shingling. Wood-based sheathing, glass-fibre-faced exterior gypsum board, or exterior gypsum board having a water vapour permeance of less than $60 \text{ ng/Pa}\cdot\text{s}\cdot\text{m}^2$ must be installed in accordance with Article 9.25.5.2., Position of Low Permeance Materials, of Division B of the NBC 2015.

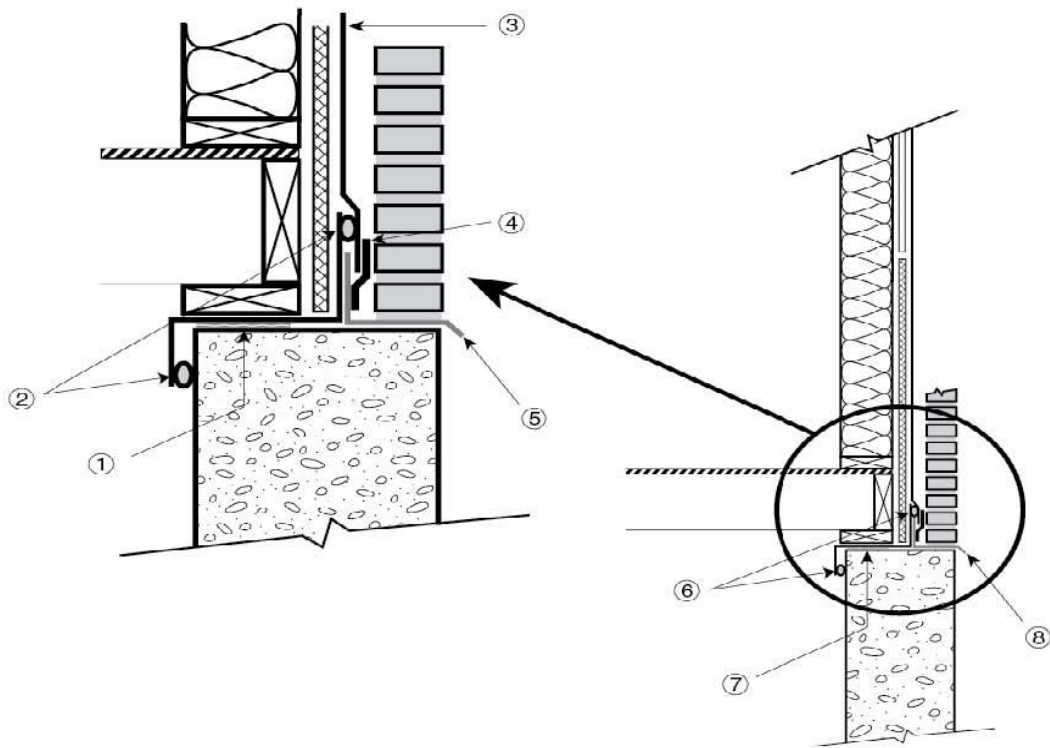

Figure 2. Bottom foundation detail for the product:

1. sill plate gasket
2. sealant
3. proprietary air barrier material
4. tape
5. flashing
6. sealant
7. sill plate gasket
8. flashing

Since the foundation wall is part of the air barrier system, the product must be sealed to the foundation wall to maintain the continuity of the plane of airtightness. The sealant used must be compatible with the product. For example, silicone-based sealants must not be used. To maintain watertightness, the product's sheathing membrane must be installed over the flashing and taped to properly drain any rain penetration breaching the cladding.

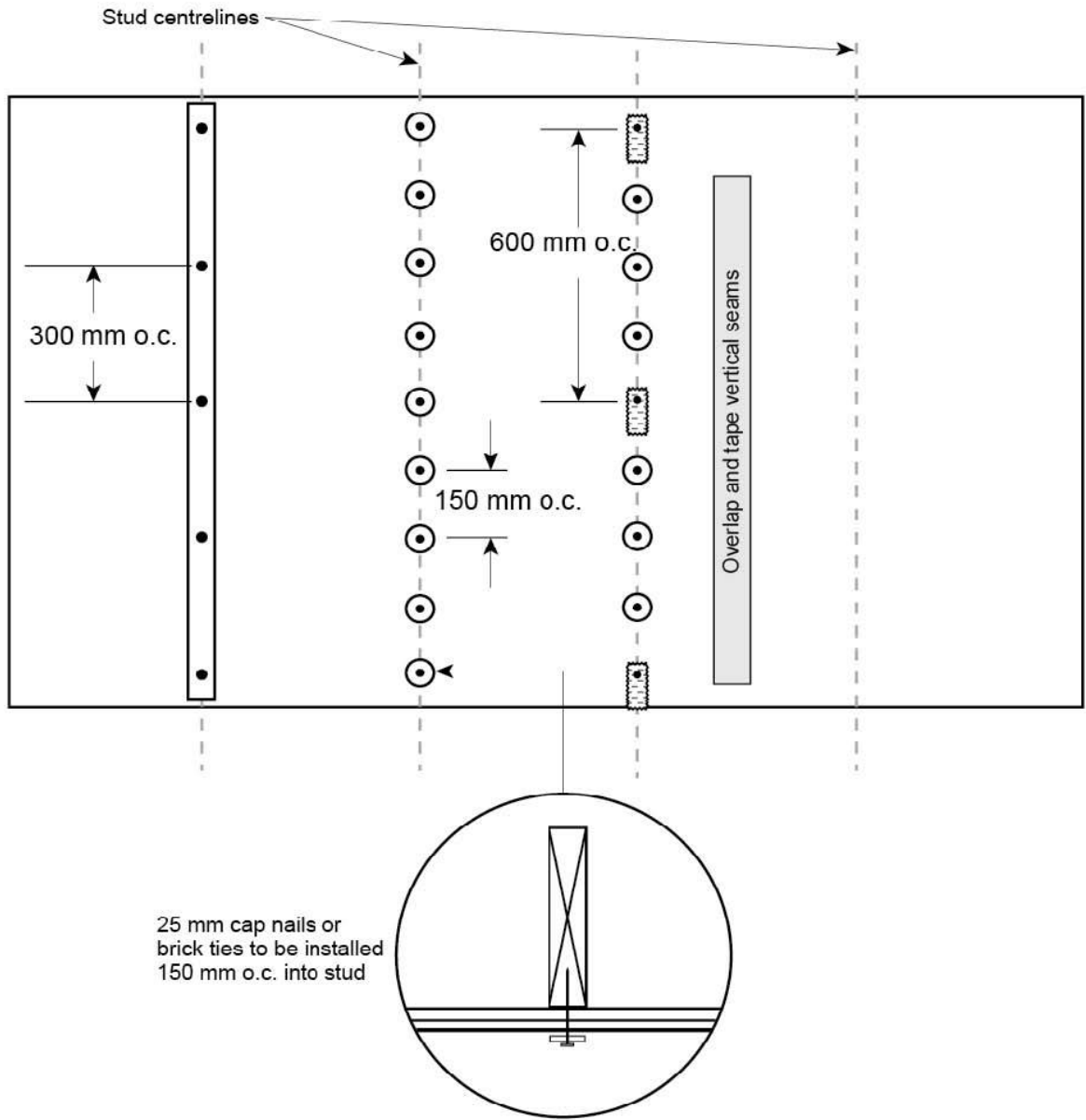

Figure 3. Structural fasteners for the product

When installed as the principal plane of airtightness the product must be structurally attached using nails with plastic washers, screws with plastic washers, or appropriate brick tie anchors.

For wood-framed construction where the sheathing is either plywood, insulated board, glass-fibre-faced exterior gypsum, or exterior gypsum board, use nails with plastic washers and brick tie anchors.

For steel-framed construction where the sheathing is either glass-fibre-faced exterior gypsum or exterior gypsum, use screws with washers and brick tie fasteners.

All seams require a 100-mm minimum overlap and both vertical and horizontal seams should be secured with a CCMC-evaluated sheathing tape.

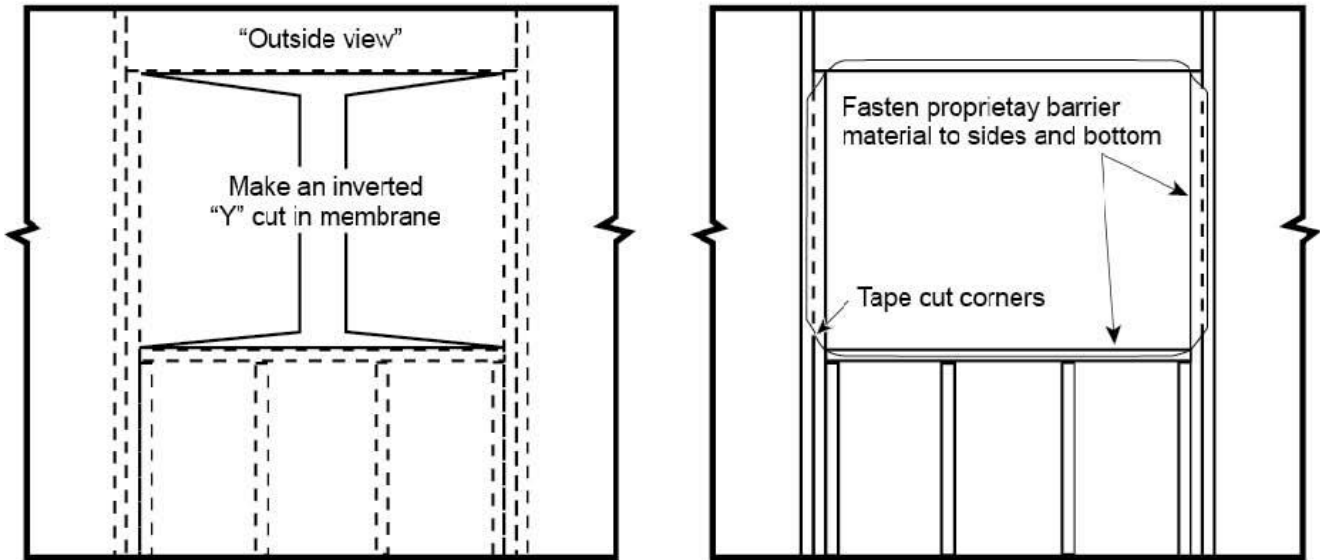

Figure 4. Window and door openings

The material must be cut and wrapped around framing at openings (see Figure 4). Cut ends should then be taped or caulked to the inside frame. To ensure continuity at this junction, a seal must be established with the window or door element (see Figure 5).

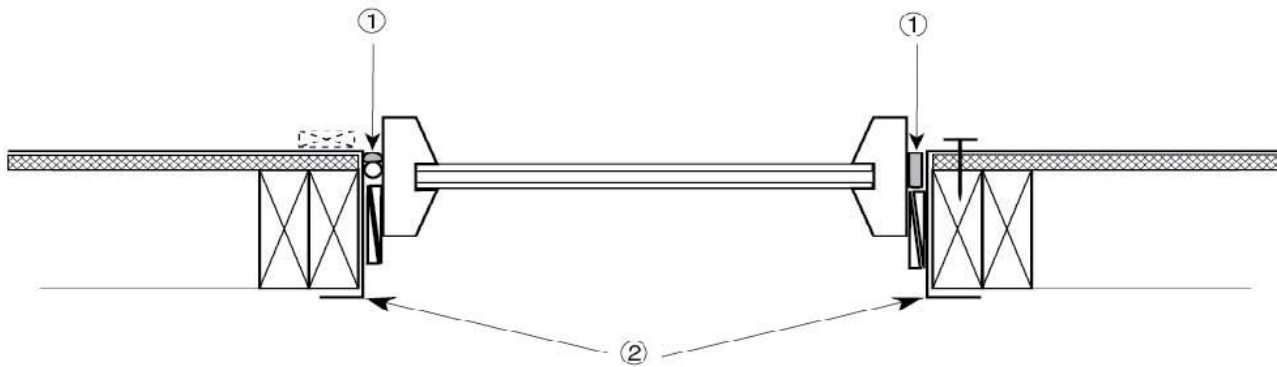

Figure 5. Window frame cross-section:

- 1. seal to window with sealant or foam compatible with proprietary air barrier material and wood/vinyl/aluminum frames**
- 2. proprietary air barrier material**

The plane of airtightness of the material must be made continuous with windows and doors that are part of the air barrier system for the building envelope. The material must be sealed to the window or door frames with either sealant/backer rod or filled with sealant foam. Sealants must be compatible with the material and adhere to the framing material.

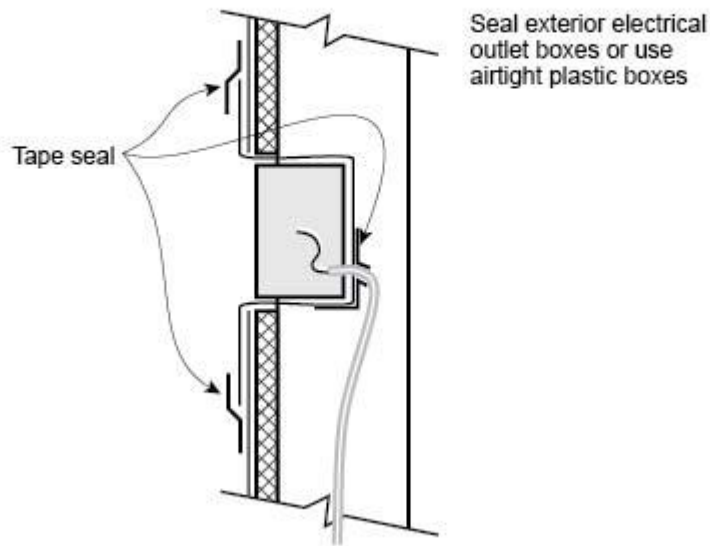
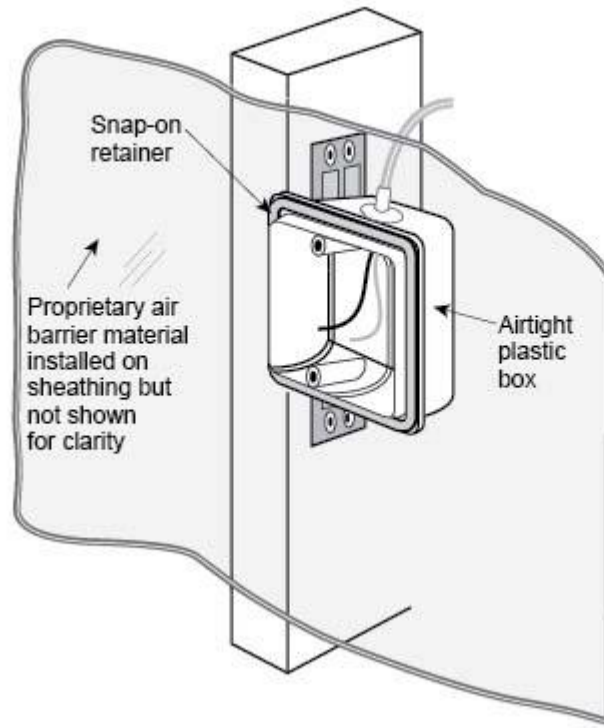

Figure 6. Exterior electrical boxes

All exterior electrical boxes or other penetrations through the material must be rendered airtight to maintain the plane of airtightness of the air barrier system. All electrical boxes must be wrapped and taped to the product's membrane, or airtight electrical boxes can be used.

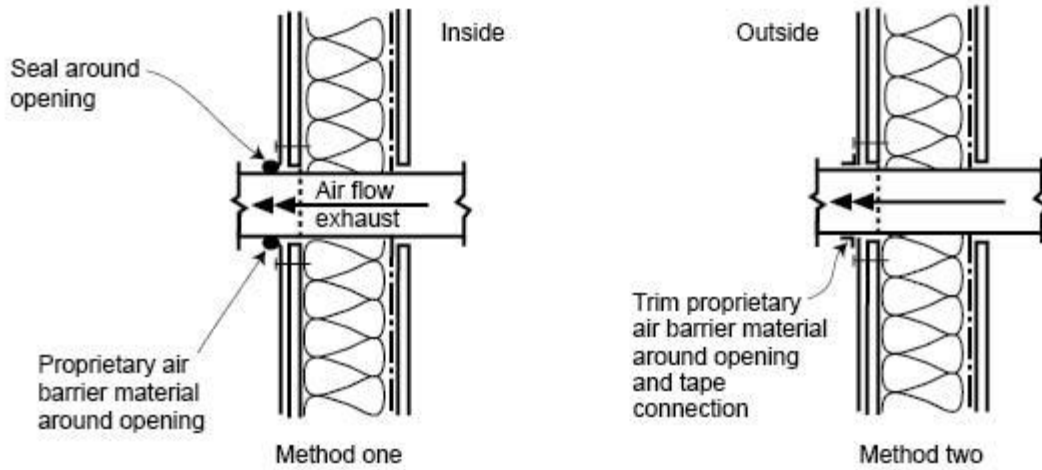

Figure 7. Sealing at wall penetrations

Where pipes and ducts may breach the product's membrane, they must be sealed to the membrane. A sealant bead or CCMC-evaluated sheathing tape compatible with the product and the pipe or duct material is recommended.