

OPENSTACK

tminn.com

PORTABLE, GUARDLESS
PALLETIZER



SCAN



Full Pallets, Fast.

The **Tishma Technologies Openstack Palletizer** is compact and portable, allowing your production to minimize operator involvement and move pallets out the door quickly.

- ▶ Less clutter in your plant with an open, guardless layout.
- ▶ Move and deploy quickly between your production lines.
- ▶ Fast cycle times to accommodate your throughput rates.
- ▶ Dual pallet docks allow for palletizing two different patterns or as buffer for full pallet storage.



CONTACT

847.884.1805

info@tminn.com

Information presented is subject to change as product improvements are made.
Contact your account representative for current specifications. Rev A.5

TECHNICAL SPECIFICATION

PAYLOAD CAPACITY	Up to 40 lbs
CYCLE TIME	Up to 15 Picks/Minute
OVERALL DIMENSIONS	W:5' L:11½' (deployed); W:5' L:3' (folded)
OVERALL MASS	2200 lbs
FRAME	Stainless Steel 304
POWER REQUIREMENT	20A 480V 3PH
AIR REQUIREMENT	100psi, 1/2" line
DRIVE	Yaskawa YRC1000 (robot controller)
ELECTRICAL CONTROLS	Keyence/SICK
HMI	Yaskawa Smart Pendant
SAFETY	Area Safety Sensors Type3, SIL2, Cat3, and PLd
ENVIRONMENT REQs.	Low Dust
ROBOT	Yaskawa GP25
FLOOR MOUNT	Four Floor Anchor Bolts
EOAT	Vacuum Gripper
MAX. PALLET HEIGHT	7'
PALLET SIZES	All Standard Pallets

WORK AREA SAFETY ZONES

Laser scanners will trigger various operation states if an operator or a foreign object enters the safety zones.

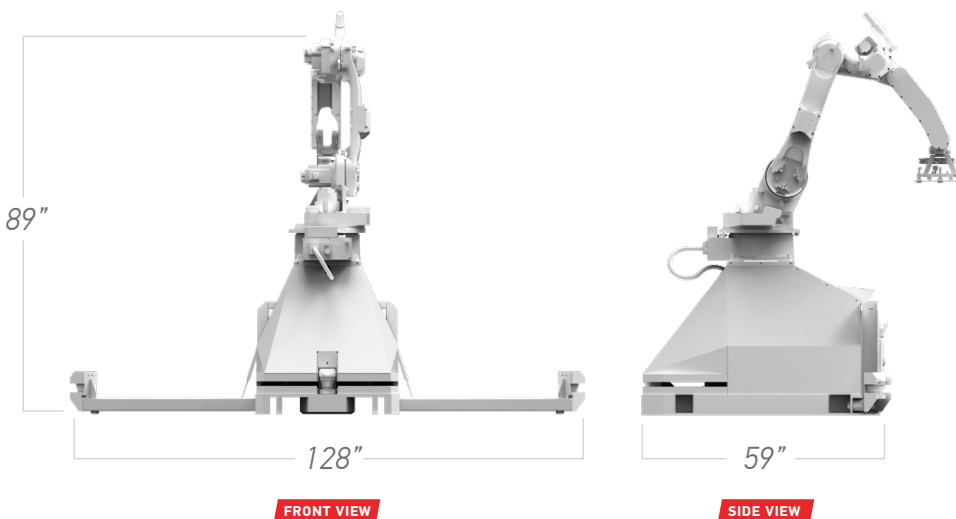
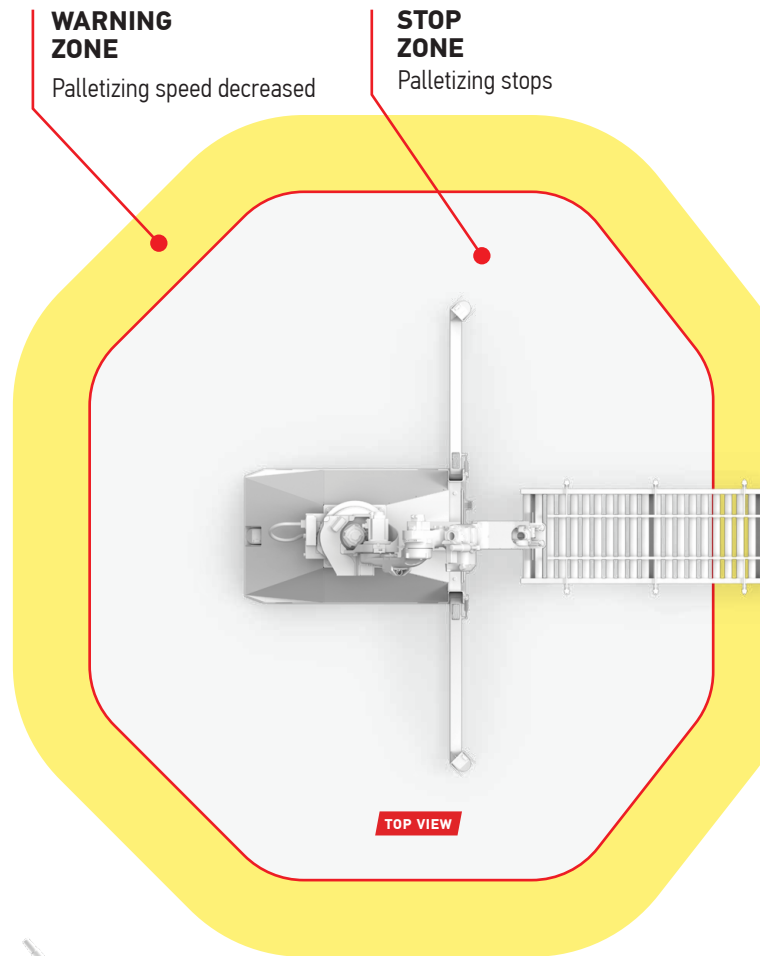

OPTIONS

- ▶ Slip/Tier Sheet Handling
- ▶ Custom EOAT Design
- ▶ Radar Micromovement Sensor for Auto-Reset

CONTACT

847.884.1805

info@tminn.com

