

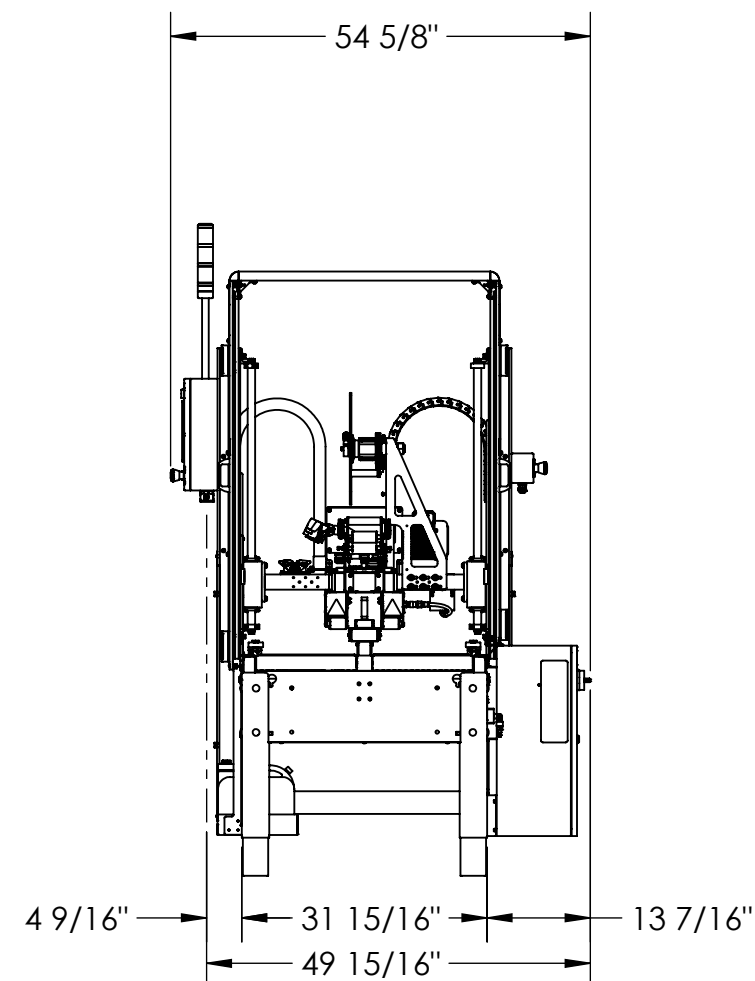

REV.	DESCRIPTION	ECN	DATE	APPD
A				

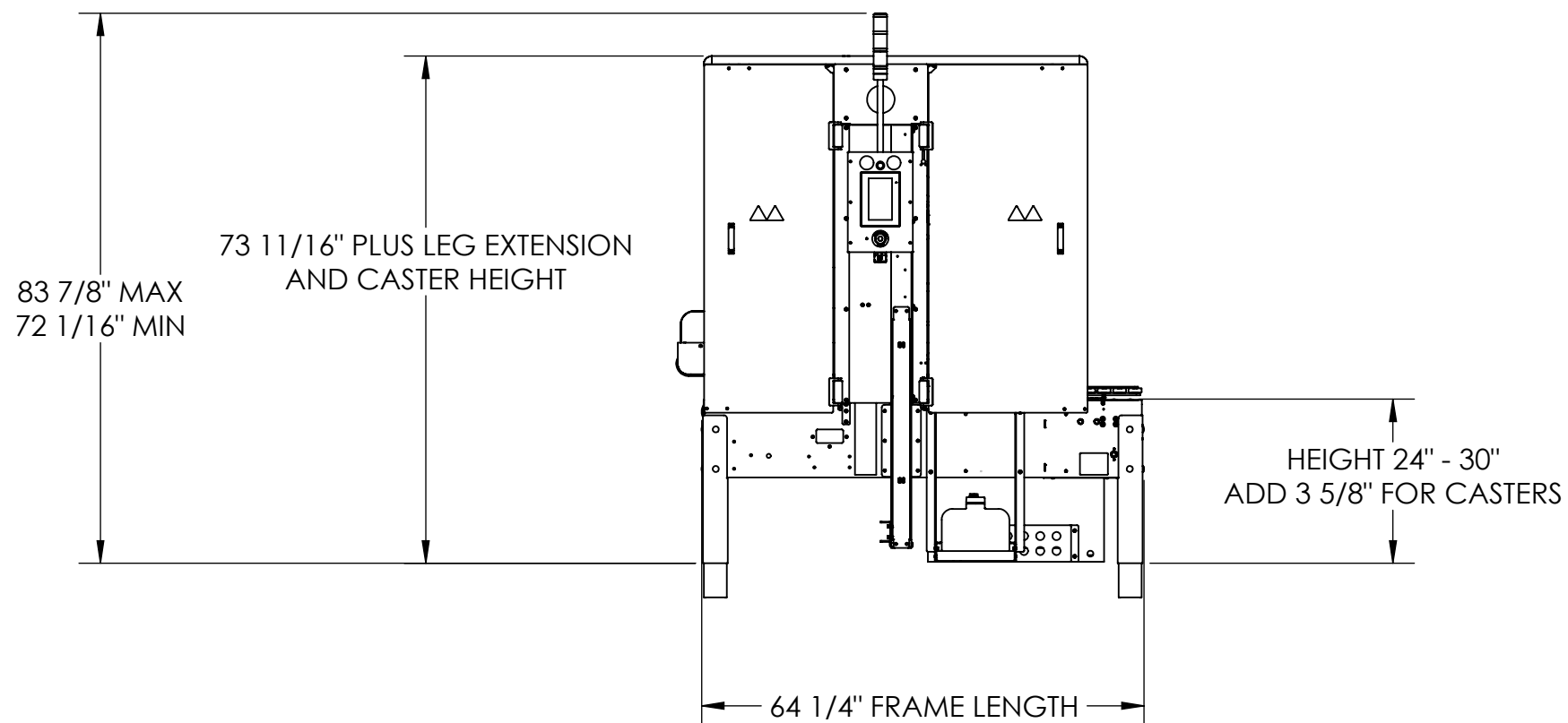
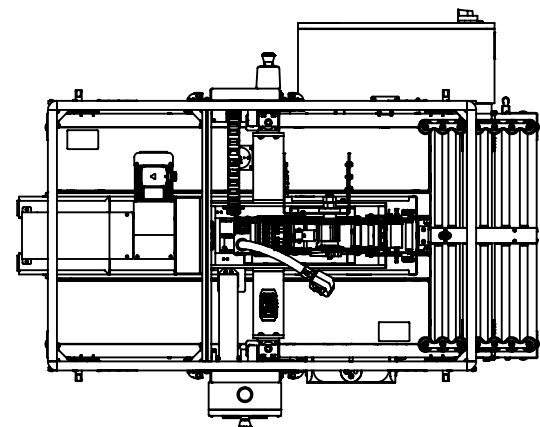

NOTES

- CASTERS (NOT SHOWN) ADD 3 5/8" TO HEIGHT
- LONGER LEGS AVAILABLE
- STACK LIGHT IS REMOVABLE FOR TRANSPORT

PROPRIETARY AND CONFIDENTIAL
 THIS DOCUMENT CONTAINS INFORMATION WHICH IS PROPRIETARY AND THE PROPERTY OF INTERTAPE POLYMER GROUP, INC. AND MAY NOT BE REPRODUCED, USED OR DISCLOSED IN WHOLE OR IN PART WITHOUT THE WRITTEN CONSENT OF INTERTAPE POLYMER GROUP, INC.

THIRD ANGLE PROJECTION

B size
 SCALE 1:25

RoHS COMPLIANCE REQUIRED

DO NOT SCALE
 DIMENSIONS ARE MILLIMETERS (INCHES) AND APPLY AFTER FINISH. BREAK AND DEBURR ALL EDGES

STANDARD TOLERANCES: INCHES ARE REFERENCE ONLY
 X [.XXX] ±0.75 [±0.030]
 .X [.XXX] ±0.25 [±0.010]
 .XX [.XXX] ±0.13 [±0.005]
 ANGLES: ± 1°

SURFACE FINISH (PRE-COATING): (UNLESS OTHERWISE SPECIFIED):

MACHINED PARTS: 1.6 Ra µm [63 Ra µin] MAX
 SHEET METAL: No. 4 SATIN MAX



intertape polymer group
 machinery division

DRAWING NO. PART NO.
 TITLE **RSA2626-TB-WAT TOP ONLY**

MATERIAL: SEE BOM

FINISH: N/A

DRAWN BY	DATE	APPROVED	DATE	REV.	SHEET
				A	1 OF 1