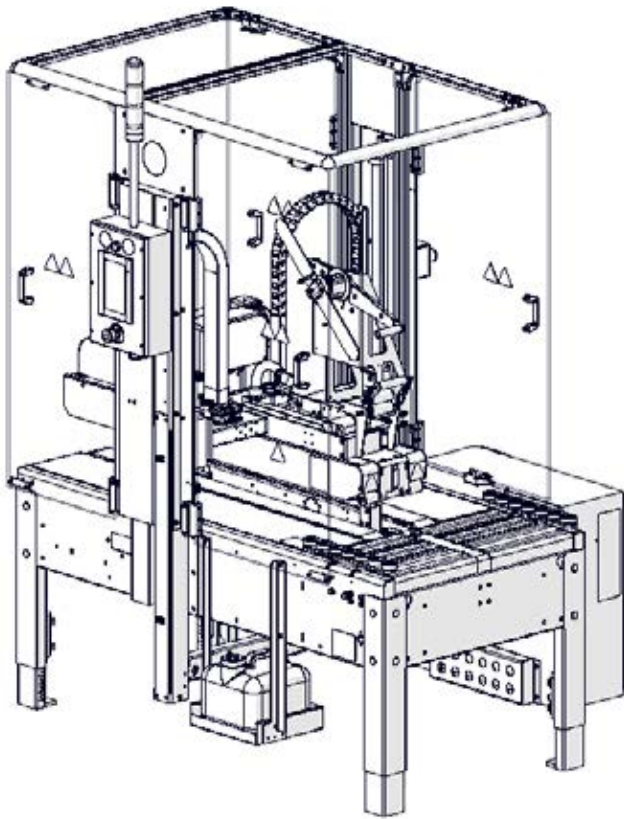




# USER MANUAL RSA 2626-WAT-TB TOP ONLY



For Serial Numbers:  
TM960 XX X XXX



[www.itape.com](http://www.itape.com)  
800-474-8273



[www.itape.com](http://www.itape.com)  
800-474-8273



# USER NOTES

---

For all IPG product manuals please visit [www.itape.com/systems-manual](http://www.itape.com/systems-manual) or use this QR code



# TABLE OF CONTENTS

<b>Technical Assistance</b>	<b>4</b>	Top Taping Parameters Screen 2	51
Replacement Parts	4	Additional Parameters Screen	52
<b>Field Service Assistance</b>	<b>5</b>	Additional Parameters Screen 2	53
<b>Warranty Information</b>	<b>6</b>	Machine Settings Screen	54
<b>General Information</b>	<b>7</b>	Home Screen Display Settings Screen	55
Description of RSA 2626-WAT-TB Top Only	7	Engineering Menu Screen	56
Definitions	7	Set Date/Time Screen	57
<b>Optional Equipment</b>	<b>8</b>	Reset Cycle/Error Counts Screen	58
Additional Tape Heads	8	Engineering Settings Screen	59
Can be installed on site	8	Calibration Screen	60
Cannot be installed on site	8	Measurements & Calculations Screen	61
<b>Important Safeguards</b>	<b>9</b>	Taping Default Parameters Screens	62
<b>Label Placement</b>	<b>10</b>	Additional Default Parameters Screens	63
<b>Safety Label Descriptions</b>	<b>12</b>	Pox Process Times Screen	64
<b>Label Descriptions</b>	<b>15</b>	<b>Preparing Cases to be Processed Continued</b>	<b>65</b>
<b>Machine Nameplate</b>	<b>16</b>	Flap Folding	65
<b>Important Safeguards</b>	<b>17</b>	Over Filled and Void Filled Cartons	65
Explanation of Signal Word Consequences	17	<b>Operation Modes</b>	<b>66</b>
Operator Skill Level Descriptions	18	Control Box	66
<b>Specifications</b>	<b>19</b>	Manual Mode	66
RSA 2626-WAT-TB Top Only Dimensions	19	Auto Mode	67
Machine Components	20	Pass Through Mode	68
Power Requirements	21	<b>Troubleshooting</b>	<b>69</b>
Pneumatic Requirements	21	Electrical Enclosure	69
Operating Speed	21	Q & A	70
Tape Specifications	22	The Machine is Turned on and Nothing Happens	71
Operating Conditions	22	Front Tape Leg Not Sticking	72
Carton Specifications	22	Rear Tape Leg Not Sticking	73
<b>Set-up Procedure</b>	<b>23</b>	Tape Does Not Cut	74
Receiving and Handling	23	Tape Jam	75
Set up	23	Wrinkles in the Tape	76
Optional Equipment: Caster Installation	24	Tape Not Dispensed	77
Optional Equipment: Infeed Table Installation	25	<b>Maintenance</b>	<b>78</b>
Optional Equipment: In-feed Table Installation (Continued)	26	Lubrication:	78
Optional Equipment: Installation of External In-feed and Exit	26	Cleaning:	78
Conveyors	27	Recommended Spare Parts:	78
<b>Connecting Utilities</b>	<b>28</b>	Changing the Air Regulator Filter	79
Electrical Utilities	28	Top Drive Belt Replacement	80
Pneumatic Utilities	29	Bottom Drive Belt Replacement	81
<b>Operator Controls</b>	<b>31</b>	<b>Appendix A</b>	<b>82</b>
Emergency Stop Locations	31	Electrical Drawing	82
<b>Top Tape Loading/Threading</b>	<b>32</b>	Pneumatic Drawing	97
Direction of Top Tape Unwind	32	<b>Appendix B</b>	<b>100</b>
Top Tape Path	32	Parts Listing	100
Top Tape Loading/Threading Instructions	33		
<b>Removing/Replacing The Top Active Taping Mechanism</b>	<b>34</b>		
<b>Adding Water to the System</b>	<b>35</b>		
<b>Adjusting the Water Level</b>	<b>36</b>		
Adjusting the top water level	36		
<b>Case Processing Procedure</b>	<b>37</b>		
<b>Operating Instructions</b>	<b>39</b>		
Carton Jam Clearing	40		
<b>HMI Window Explanations</b>	<b>41</b>		
Main Screen	41		
Main Menu Screen	42		
Manual Screen	43		
I/O Menu Screen	44		
PLC Inputs Screen	45		
PLC Outputs Screen	46		
Cycle Counts Screen	47		
Error Counts Screen	48		
Settings Menu Screen	49		
Top Taping Parameters Screen 1	50		

# TECHNICAL ASSISTANCE

---

This is the Interpack Model **AUTO H2O Random Semi-Automatic-Water Activated Tape (RSA 2626-WAT-TB Top Only)** Top-Belt Case Sealer you ordered. It has been set up and tested in our factory with IPG manufactured Water Activated Tape. If any problems occur when setting up or operating this equipment, please contact the authorized distributor from where you purchased this item.

If contact with the authorized distributor is not possible, **IPG Machinery Support** is available. Should the need to contact **IPG Machinery Support** arise, **please have the equipment model and serial number available prior to contact**. This information can be found on the nameplate of the tape head as well as on the machine, both sets of information may be necessary to assist. A section at the bottom of this page is available to write this information down. **IPG Machinery Support** is available during normal business hours (M-F 8am-7pm) Eastern Time.

Phone: 813-345-3070

Email: [machsupp@itape.com](mailto:machsupp@itape.com)

## Replacement Parts

A breakdown of parts, including part numbers, can be found in the appendix of this manual. If you know the part number that you require please contact your authorized distributor or IPG Customer Service 877-447-4832 Option 3

Please use this area to enter the detailed information on your Case Sealer and Tape Heads. This should be filled out at the time of install. This information can be found on the nameplate of the machine, typically on the side the operator controls are on.

## Machine

### Model

### Serial

### Distributor

### Name

### Phone/Email

### Date of Purchase

### Date of Install

# FIELD SERVICE ASSISTANCE

---

Your Interpack Case Sealer and Tape Heads are designed to provide years of trouble free operation. This is not without proper preventative maintenance, a recommended schedule can be located in the maintenance section of this manual, performed by the end user of the equipment. If any problems arise with this machine during the normal course of operation, your properly trained and qualified internal service personnel should be able to repair any issues after consulting the troubleshooting section of this manual in conjunction with phone and/or email support from IPG Machinery Support.

Field Service Support is available from your IPG Authorized Distributor at additional cost if the problem cannot be remedied after consulting the troubleshooting section of this manual.

IPG offers comprehensive programs that help keep your equipment up and running.

Proactive maintenance efforts help to prevent equipment failures and costly emergency repairs. Keeping your machine in optimal working condition also enhances employee safety, reduces facility downtime and efficiently allocates internal resources.

Please contact your IPG Representative to discuss the best options for your IPG equipment.

# WARRANTY INFORMATION

---

EQUIPMENT WARRANTY AND LIMITED REMEDY: The following warranty is made in lieu of all other warranties, express or implied, including, but not limited to, the implied warranty of merchantability, the implied warranty of fitness for a particular purpose, and any implied warranty arising out of a course of dealing, a custom or usage of trade:

Intertape sells its Interpack Tape Heads, Case Tapers and Case Erectors with the following warranties:

1. The IPG Pressure Sensitive Tape Heads' knife blades, springs and wipe down rollers will be free from all defects for a period of ninety (90) days.
2. All other IPG Pressure Sensitive Tape Head parts will be free from all defects for one (1) year after delivery.
3. Water Activated Tape Heads' blades will be free from defects for ninety (90) days after delivery.
4. Drive Belts will be free from defects for ninety (90) days after delivery
5. The Gear Motors will be free from defects for one (1) year after delivery.
6. All other components for Case Tapers and Case Erectors will be free from defects for one (1) year after delivery.

If any part is proven defective within its warranty period, then the exclusive remedy and Intertape's and the seller's sole obligation shall be, at Intertape's option, to repair or replace the part, provided the defective part is returned immediately to Intertape's factory or an authorized service station designated by Intertape.

A part will be presumed to have become defective after its warranty period unless the part is received or Intertape is notified of the problem no later than five (5) calendar days after the warranty period.

If Intertape is unable to repair or replace the part within a reasonable time, then Intertape, at its option, will replace the equipment or refund the purchase price. Intertape shall have no obligation to install the repaired or replacement part.

Intertape shall have no obligation to provide or pay for the labor required to install the repaired or replacement part.

Intertape shall have no obligation to repair or replace (1) those parts failing due to: operator misuse, carelessness, or due to any accidental cause other than equipment failure, or (2) parts

1. Failure or damage is due to misapplication, lack of proper maintenance, abuse, improper installation or abnormal conditions such as temperature, moisture, dirt or corrosive matter, etc.
2. Failure due to inadequate cleaning, improper operating environment, improper utilities or operator error.
3. Failure due to operations above the rated capacities, or in any other improper manner, either intentional or otherwise.
4. Failure is due to equipment, which has been altered by anyone other than an authorized representative of Intertape Polymer Group.
5. Failure is due to an attempt by the purchaser to correct alleged defective equipment. In this event the purchaser is responsible for all expenses incurred.

LIMITATION OF LIABILITY: Intertape and seller shall not be liable for direct, indirect, special, incidental or consequential damages based upon breach of warranty, breach of contract, negligence, strict liability or any other legal theory.

The foregoing Equipment Warranty and Limited Remedy and Limitation of Liability may be changed only by written agreement signed by authorized officers of Intertape and seller.

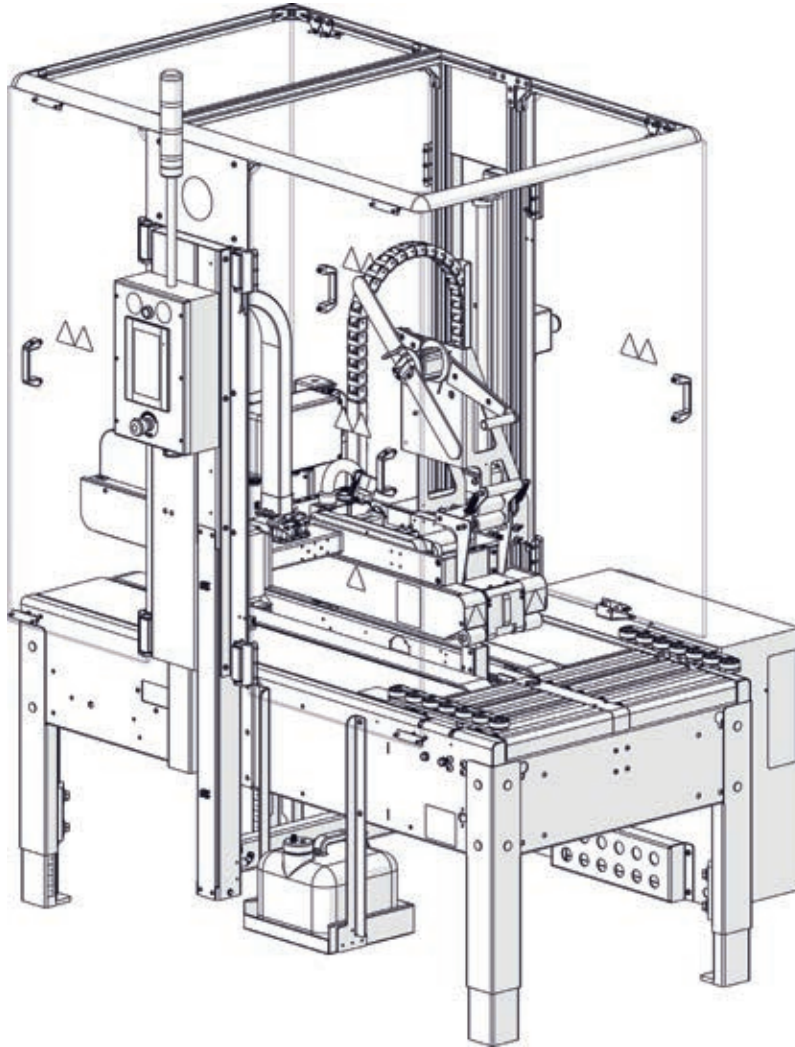
# GENERAL INFORMATION

---

## Description of RSA 2626-WAT-TB Top Only

This machine is designed to provide years of trouble free operation. If any problems arise with this machine during the normal course of operation, your properly trained and qualified internal service personnel should be able to repair any issues after consulting the [Troubleshooting](#) section of this manual.

The **RSA 2626-WAT-TB Top Only** Case Sealer is designed to apply IPG brand water activated tape (WAT) to the top center seam of regular slotted corrugated cartons. The **RSA 2626-WAT-TB Top Only** Case Sealer automatically adjusts to a variety of case sizes.



**Figure 1: RSA 2626-WAT-TB Top Only**

## Definitions

Common terms that will be used throughout this manual.

**Tape Head** – This will refer to the WAT Top tape mechanism(s) for the remainder of this manual

**Case Sealer** – Refers to IPG manufactured Case Sealers

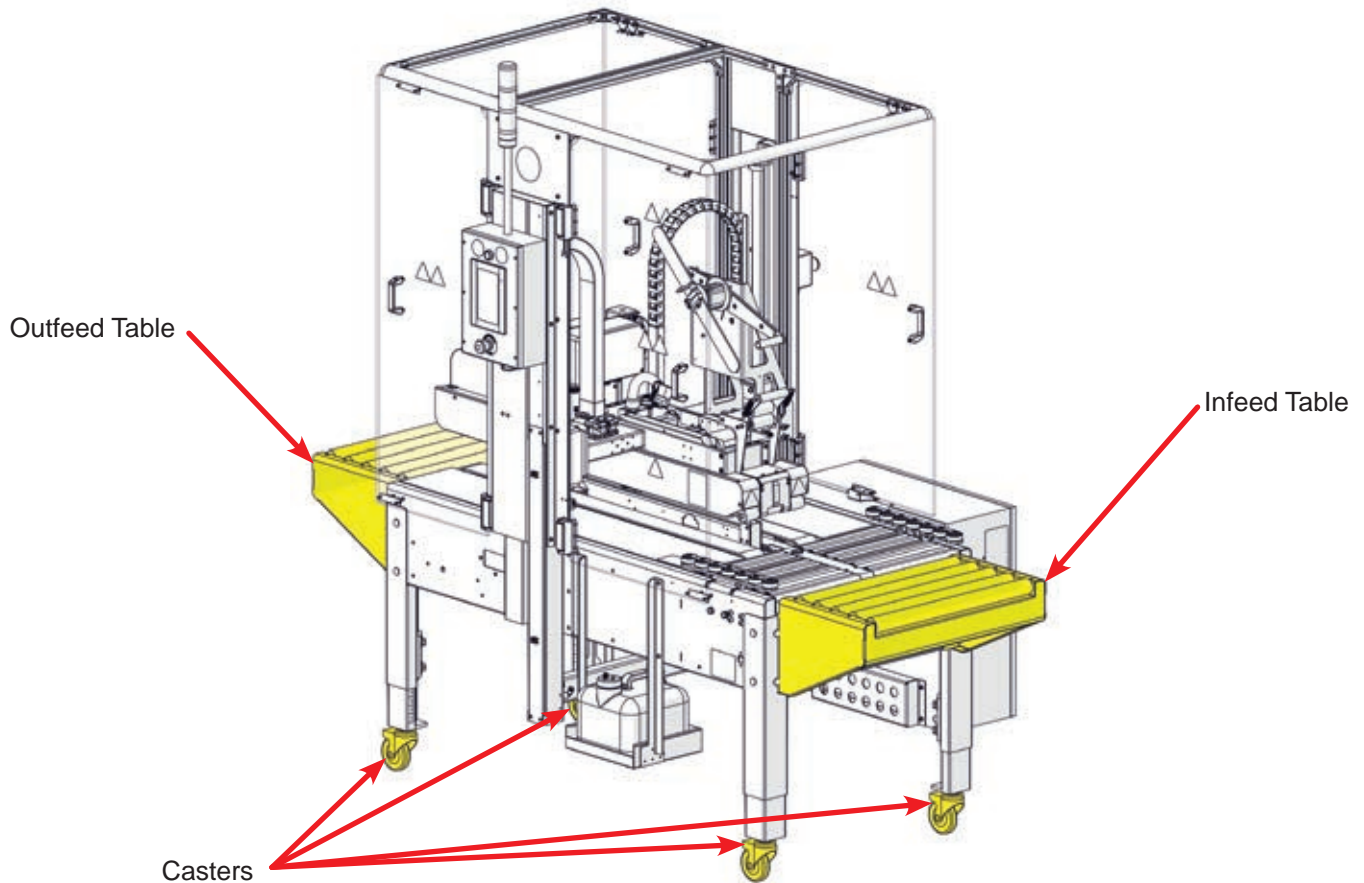
**Machine System** – Refers to the fully assembled Case Sealer with the Tape Head(s) installed

**User/Operator** – The individual who has been trained on the daily use of the Machine System

**Maintenance Champion** – The individual(s) who work for the end user of the Machine System who are responsible for conducting general and preventative maintenance

# OPTIONAL EQUIPMENT

The **RSA 2626-WAT-TB Top Only** can be outfitted with a variety of optional equipment. The below list is **not** standard and should be discussed with your distributor or authorized IPG representative if you would like them to be added to your machine.



**Figure 2: Optional Equipment**

## Additional Tape Heads

It is recommended to keep a spare top tape head in the event any failure or malfunction causes the machine to stop production. This is to help reduce any possible downtime.

## Can be installed on site

Description	Item Number	Quantity Per Machine
<a href="#">Infeed Table .4M (16")</a>	<a href="#">UM894T</a>	1
<a href="#">Infeed Table .6M (24")</a>	<a href="#">UM998T</a>	1
<a href="#">Infeed Table .9M (36")</a>	<a href="#">UM898T</a>	1
Casters	UM841	1 set of 4 (36" Feed Table will require 2 additional casters)

## Cannot be installed on site

The reversal of the electrical cabinet, operator controls, and tape mandrel is possible but is only recommended to be done at the factory prior to shipment. Additional Emergency-Stop buttons can also be added by the factory prior to shipment.

# IMPORTANT SAFEGUARDS

---

There are a number of safety labels used on the **RSA 2626-WAT-TB Top Only** Case Sealer. These labels are placed at different locations on the machine to warn operators and service personnel of possible dangers (refer to Figure 3). Please read the labels on the machine and the following safety precautions before using the machine.

**Read this manual for other important safety operating and service information.**

**Only trained personnel are to operate machine.**

**Only fully qualified technicians are to service this machine.**

**Wear safety glasses.**

**Shut off power to machine before adjusting machine or loading & threading Tape Heads.**

**Disconnect electrical power and compressed air (where applicable) before servicing.**

**Follow Lock Out / Tag Out Procedures BEFORE servicing any machinery.**

**All factory installed covers and guards must be in place before operating.**

**Stay clear of moving parts which can shear and cut.**

Should any of the safety labels on the Case Sealer be damaged or destroyed, replacements can be ordered through your distributor.

# LABEL PLACEMENT

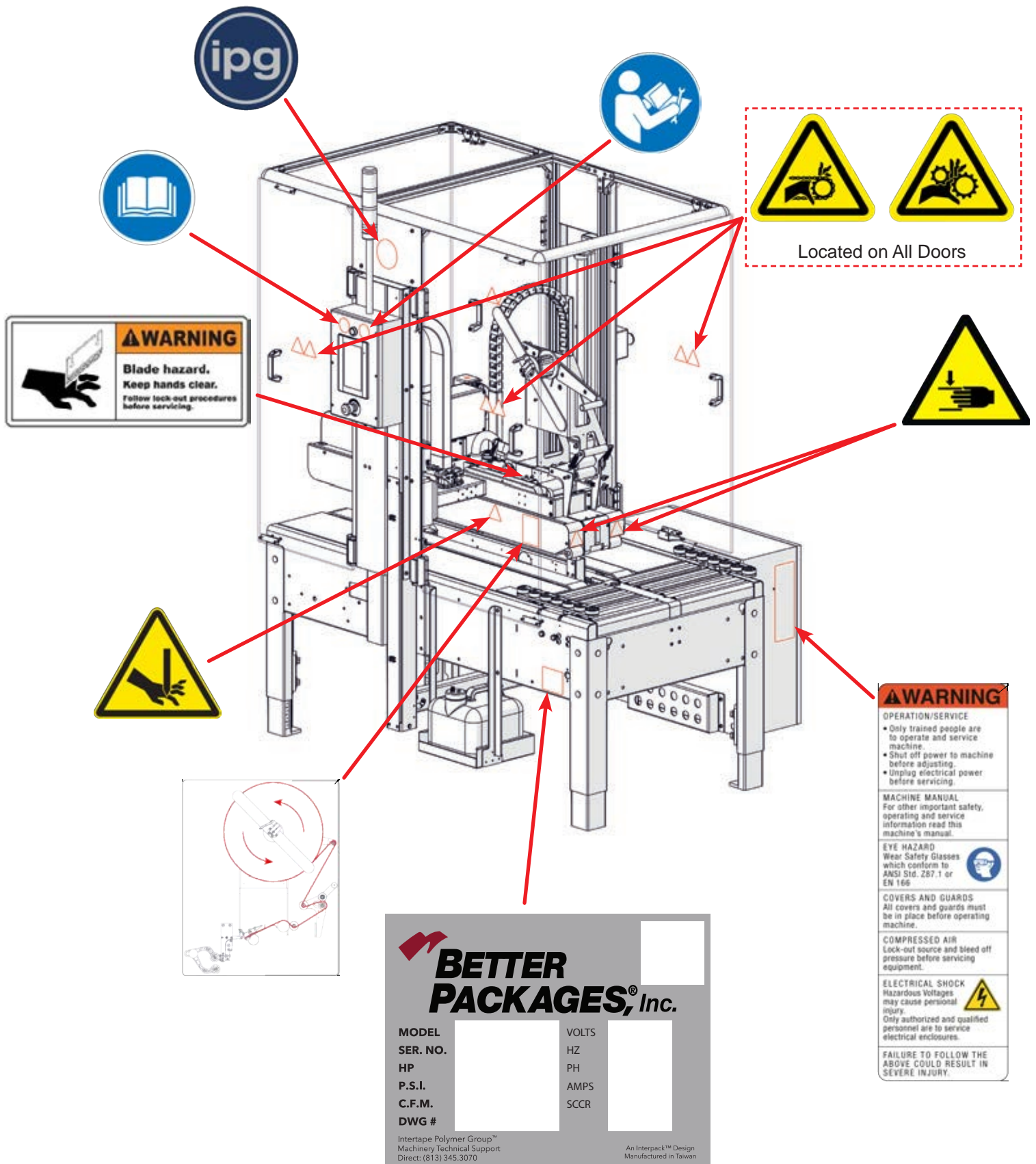


Figure 3: Label Placement 1

# LABEL PLACEMENT

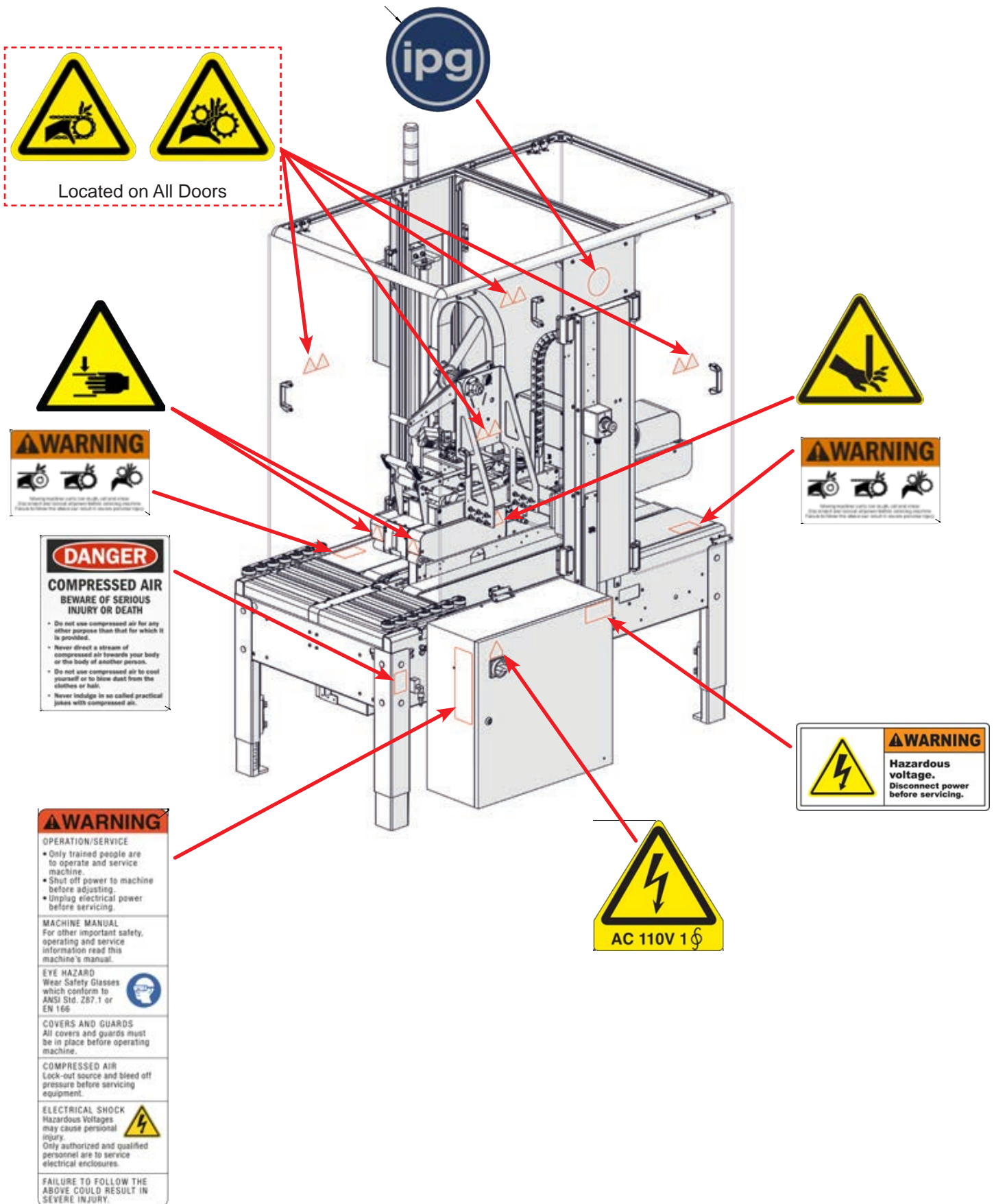








Figure 4: Label Placement 2

# SAFETY LABEL DESCRIPTIONS

<p>The labels shown is affixed to the upper tape head.</p> <p>It warns operators and service personnel of the presence of the cutting blade that may not be visible. Caution should be exercised when approaching this area.</p> <p>Reorder number: UPM8174</p>	 <p><b>Figure 5: Blade Hazard</b></p>
<p>The labels shown is affixed to both sides of the bridge frame nearest to the tape head.</p> <p>It warns operators and service personnel of the presence of the cutting blade that may not be visible. Caution should be exercised when approaching this area.</p> <p>Reorder number: UPM8205</p>	 <p><b>Figure 6: Blade Hazard</b></p>
<p>The label shown is affixed to the upper tape head assembly on either side of the machine.</p> <p>It warns operators and service personnel of a potential crush hazard when cases are moving through the case sealer.</p> <p>Reorder number: UPM8206</p>	 <p><b>Figure 7: Crush Hazard</b></p>
<p>The label shown is located on the bottom tape carriage.</p> <p>The label warns the operators and service personnel of the pinch points from rotating elements.</p>	 <p><b>Figure 8: Drive Base Hazard</b></p>
<p>The label shown is affixed to the electrical control box.</p> <p>The label advises service personnel of live electrical current when the machine is plugged in.</p> <p>Reorder number: UPM2011</p>	 <p><b>Figure 9: Hazardous Voltage</b></p>
<p>The label shown is affixed to the electrical control box, and all area where live electrical current is present when the machine is in operation.</p> <p>The label advises service personnel of live electrical current when the machine is plugged in.</p> <p>Reorder number: UPM8207</p>	 <p><b>Figure 10: Hazardous Voltage</b></p>

Should any of the safety labels on the Case Sealer be damaged or destroyed, replacements can be ordered through your distributor.

# SAFETY LABEL DESCRIPTIONS CONTINUED

The label shown is located on the side of the column.

This label provides convenient safety instructions for the operator and service personnel in the operation of the IPG Case Sealing Equipment.

Reorder number: UPM2012



Figure 11: Safety Instructions

The label shown is located on the in-feed end

of the machine. The label advises personnel about the dangers of the machine due to compressed air used in the system. Be aware of warnings and proper procedures when running and/or servicing the machine.

Reorder number: UPM8208



Figure 12: Compressed Air

Should any of the safety labels on the Case Sealer be damaged or destroyed, replacements can be ordered through your distributor.

# SAFETY LABEL DESCRIPTIONS CONTINUED

The label shown is located on the in-feed and exit ends of the machine belt drives.

The label advises operators to keep their hands clear of moving chain components.

Reorder number: UPM8209



**Figure 13: Chain Hazard**

The label shown is located on the in-feed and exit ends of the machine belt drives.

The label advises operators to keep their hands clear of moving gear components.

Reorder number: UPM8210



**Figure 14: Gear Hazard**

The label shown is located on the left machine column above the operator control box.

The label advises service personnel to read the maintenance instructions thoroughly before conducting any work.

Reorder number: UPM8211



**Figure 15: Read Service Manual**

The label shown is located on the left machine column above the operator control box.

The label advises operators to read the user manual thoroughly before operating the machinery.

Reorder number: UPM8212



**Figure 16: Read Operator Manual**

The label shown is located on the door to the electrical cabinet above the main power switch.

The label advises operators and service personnel of main supply voltage and phase.

Reorder number: UPM8219



**Figure 17: Supply Voltage**

Should any of the safety labels on the Case Sealer be damaged or destroyed, replacements can be ordered through your distributor.

# LABEL DESCRIPTIONS

The labels shown is affixed to both bottom fill covers. It alerts operators to keep clear of moving belts. This include loose clothing.

Reorder number: UPM2220

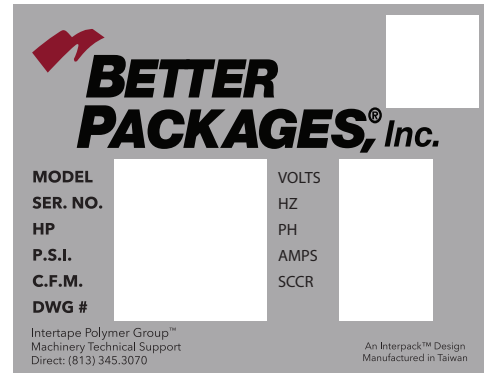


**Figure 18: Belt Hazard**

The labels shown is affixed to the left side frame of the machine on the infeed side of the operator control box.

It is the Better Packages nameplate for the Auto H2O line of machinery.

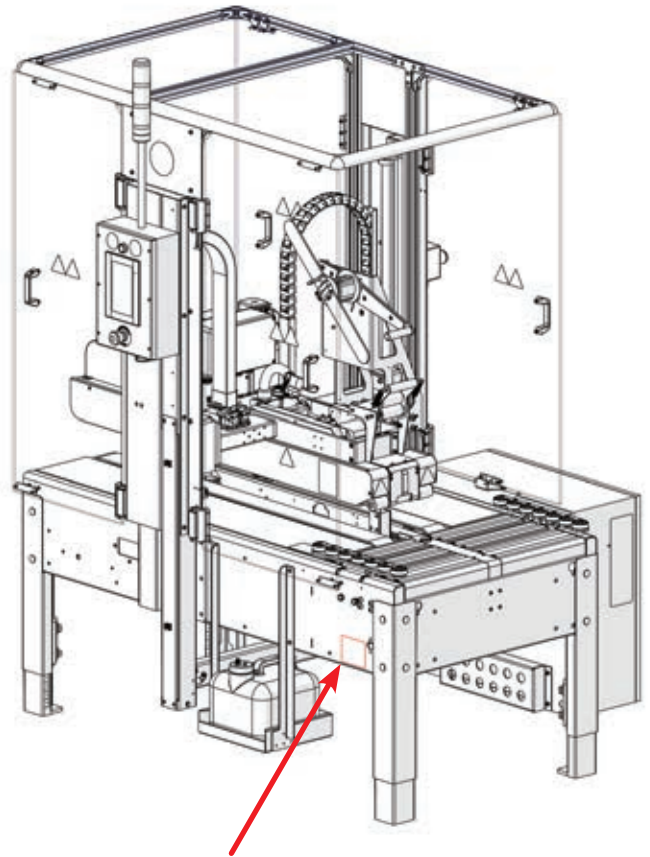
Reorder number: UPM8216



**Figure 19: Machine Nameplate**

Should any of the safety labels on the Case Sealer be damaged or destroyed, replacements can be ordered through your distributor.

# MACHINE NAMEPLATE



Machine Identification and Motor Power

Machine Pneumatic Requirements if applicable

Applicable Machine Drawing Number

Manufacturer Details

Machine Electrical Requirements

**BETTER PACKAGES<sup>®</sup>, Inc.**

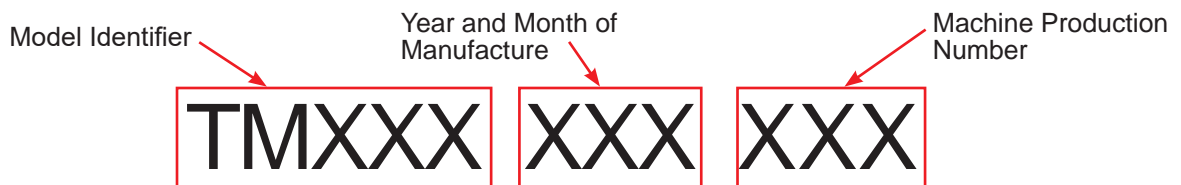
<b>MODEL</b>	RSA 2626-WAT-TB	<b>VOLTS</b>	110
<b>SER. NO.</b>	TMXXXXXXXXXX	<b>HZ</b>	60
<b>HP</b>	2x 1/3HP	<b>PH</b>	1
<b>P.S.I.</b>	75 PSI	<b>AMPS</b>	7.6
<b>C.F.M.</b>	9	<b>SCCR</b>	
<b>DWG #</b>			

Intertape Polymer Group™  
Machinery Technical Support  
Direct: (813) 345.3070

An Interpack™ Design  
Manufactured in Taiwan

Figure 20: Machine Nameplate

## Reading Interpack Serial Numbers



# IMPORTANT SAFEGUARDS

---

## Explanation of Signal Word Consequences



**WARNING: INDICATES A POTENTIALLY HAZARDOUS SITUATION, WHICH IF NOT AVOIDED COULD RESULT IN DEATH OR SERIOUS INJURY OR PROPERTY DAMAGE**



**CAUTION: INDICATES A POTENTIALLY HAZARDOUS SITUATION, WHICH IF NOT AVOIDED COULD RESULT IN MINOR OR MODERATE INJURY OR PROPERTY DAMAGE**



### **WARNING**

1. **To reduce the risk associated with mechanical, pneumatic, and electrical hazards:**
  - Read, understand, and follow all safety and operating instructions before operating or servicing the Case Sealer and/or Tape Head(s)
  - Allow only properly trained and qualified personnel to operate and service this equipment
2. **To reduce the risk associated with pinches, entanglement, and hazardous voltage:**
  - Turn electrical supply off and disconnect before performing any adjustments, maintenance, or servicing the Case Sealer or Tape Head
3. **To reduce the risk associated with pinches and entanglement hazards:**
  - Do not leave the Case Sealer running while unattended
  - Turn the Case Sealer off when not in use
  - Never attempt to work on any part of the Case Sealer, Tape Head, load tape, or remove jammed boxes from the Case Sealer while the machine is running
4. **To reduce the risk associated with hazardous voltage**
  - Position electrical cord away from foot traffic and vehicle traffic
  - Do not operate the Case Sealer with a damaged power cord
5. **To reduce the risk associated with sharp blades hazards:**
  - Keep hand and fingers away from the tape cutoff blades, the blades are very sharp
6. **To reduce the risk associated with fire and explosion hazards:**
  - Do not operate this equipment in potentially flammable and/or explosive environments
7. **To reduce the risk associated with muscle strain:**
  - Use the appropriate rigging and material handling equipment when lifting or repositioning this equipment
  - Use proper body mechanics when removing or installing Tape Heads that are moderately heavy or may be considered awkward to lift
8. **To reduce the risk associated with mechanical, pneumatic, and electrical hazards:**
  - Allow only properly trained and qualified personnel to operate and service this equipment



### **CAUTION**

1. **To reduce the risk associated with pinch hazards:**
  - Keep hands clear of the upper head support assembly as boxes are transported through the Case Sealer
  - Keep hands, hair, loose clothing, and jewelry away from box compression rollers, moving belts, and Tape Heads
  - Always feed boxes into the Case Sealer by pushing only from the end of the box

# IMPORTANT SAFEGUARDS

## Operator Skill Level Descriptions

These descriptions and levels are uniform across all IPG Case Sealers

### Skill “A” Machine Operator

This operator is trained to use the Case Sealer with the machine controls, to feed cases into the machine, make adjustments for different case sizes (USA series machines), to change tape, to start, stop, and restart production, and to clear jams and perform basic troubleshooting.

**Important:** The end user area supervisor must ensure that the operator has been properly trained on all machine functions before operating the machine.

### Skill “B” Mechanical Maintenance Technician

Also referred to as the Maintenance Champion, this technician, is trained to use the Case Sealer as the Operator is able and in addition is able to work with the safety protection disconnected to check and adjust mechanical components, to perform maintenance operations and repair the Case Sealer. A skill “B” operator is not allowed to work on live electrical components.

### Skill “C” Electrical Maintenance Technician

This technician is trained to use the Case Sealer as the Operator is able and in addition is able to work with the safety protection disconnected, to check and adjust mechanical components, to perform maintenance operations and repair the Case Sealer. A skill “C” operator is allowed to work on live electrical panels, terminal blocks, and control equipment.

### Skill “D” Manufacturer Technician

Skilled technician sent by the manufacturer or its agent (distributors) to perform complex repairs of modifications, when agreed with the customer.

### Operators skill level required to perform the following tasks on the Machine System

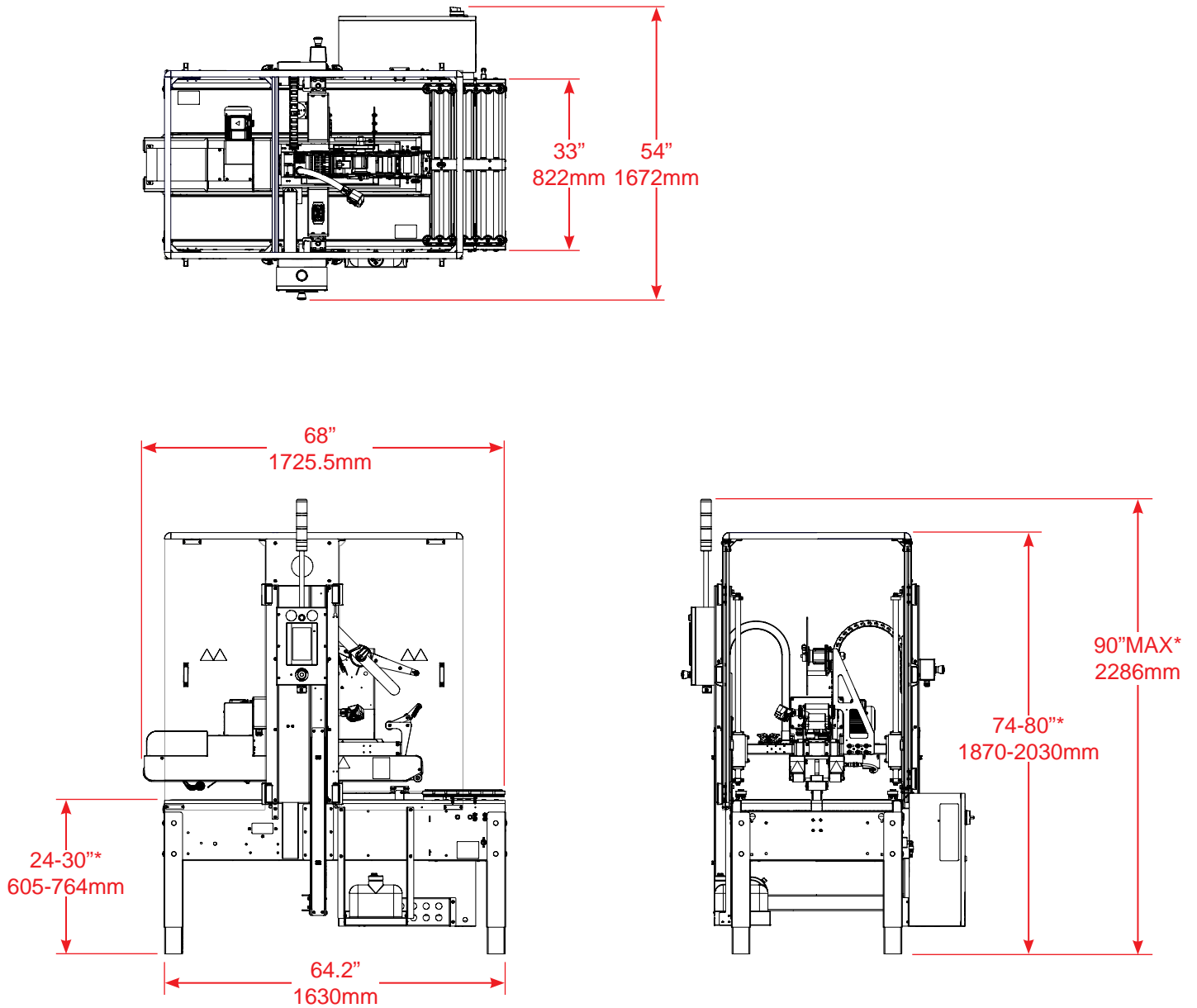
OPERATION	MACHINE CONDITION	OPERATOR SKILL LEVEL	NUMBER OF OPERATORS
Tape Roll Replacement	Stopped by pressing the Emergency Stop Button	A	1
Blade Replacement	Electrical Power Disconnected	B	1
Ordinary Maintenance and Preventative Maintenance	Electrical Power Disconnected	B	1
Extraordinary Electrical Maintenance	Running with Safety Protections Disabled	C	1
Extraordinary Mechanical Maintenance	Running with Safety Protections Disabled	D	1
Drive Belt Replacement	Electrical Power Disconnected	B	1
Machine Installation & Set-Up	Running with Safety Protections Disabled	B & D	2

**Proper Electrical Disconnect is achieved when the machine is unplugged from the electrical socket.**

# SPECIFICATIONS

## RSA 2626-WAT-TB Top Only Dimensions

Machine Weight: 950 lbs. (431kg)



\* Height notated is with standard legs. If a different range is necessary please contact your Authorized IPG Representative for additional conveyor height options. If optional casters are added they will add 4" (102mm) to the conveyor height.

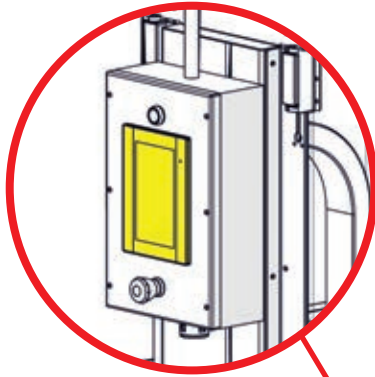
**Figure 21: Machine Dimensions**

# SPECIFICATIONS

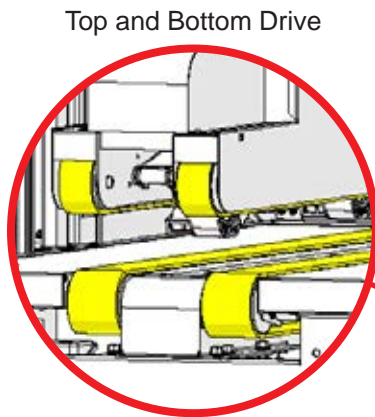
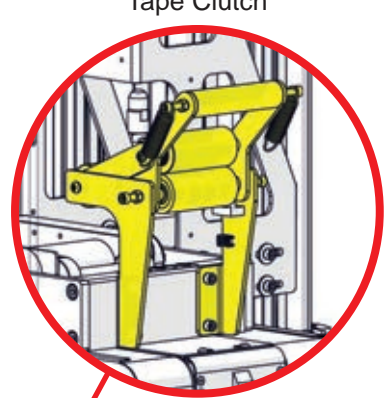
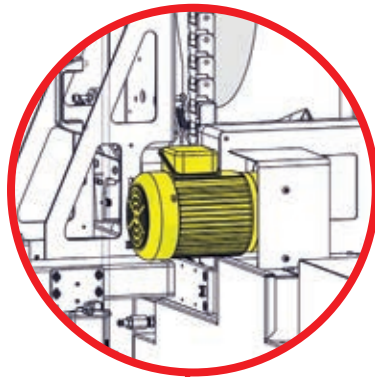
## Machine Components

1/3HP Motors to Process 80b Cases

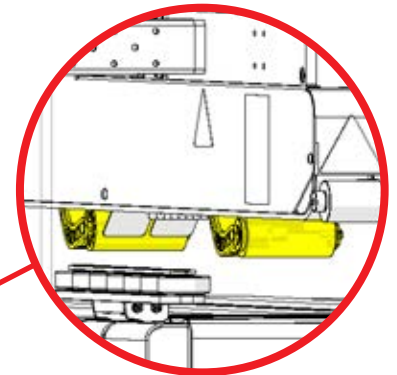
Tape Clutch



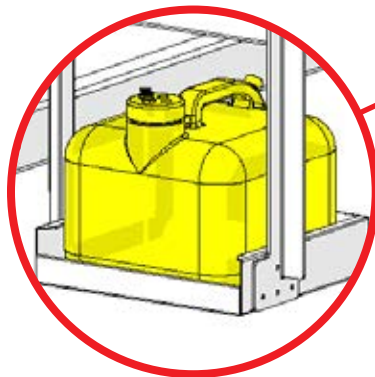
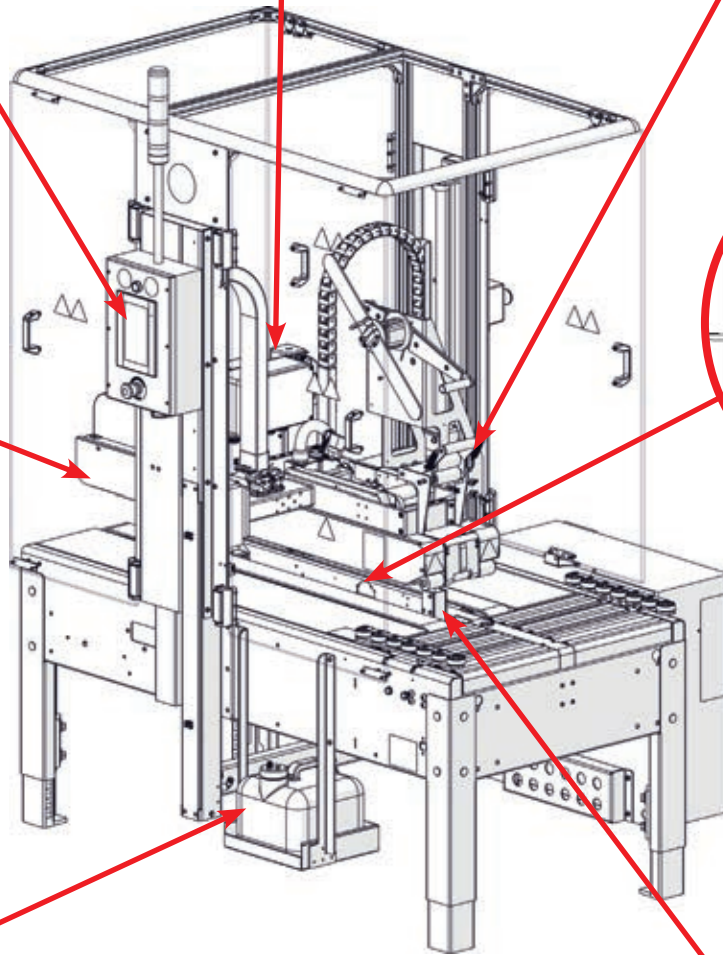
Operator Controls



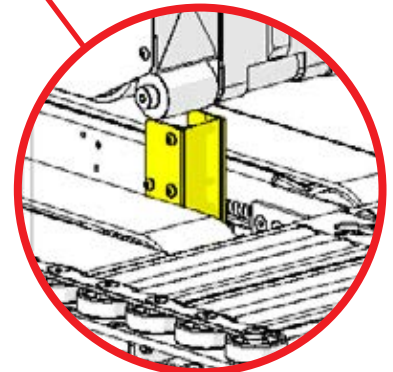
Top and Bottom Drive



Dual Pneumatic Wipedown



Large Capacity Water Container



Pneumatic Gate

Figure 22: Machine Components

# SPECIFICATIONS

## Power Requirements

Electrical: **110v, 60HZ, 15A (1650 Watts)**

This machine comes standard with two gear motors, an electrical box, and a control box.

The control box contains the **HMI Screen**, an **Emergency Stop** switch, and a **Reset** button.

A 12 ft. (3.6 m) standard, three-conductor power cord with plug is provided for **110V, 60HZ, 15A** service. The receptacle providing this service **must** be properly grounded and installed by a licensed electrician.

## Pneumatic Requirements

Compressed Air Supply: 9CFM at 90 PSI (28.3 Liter/min at 620.5 kPa)

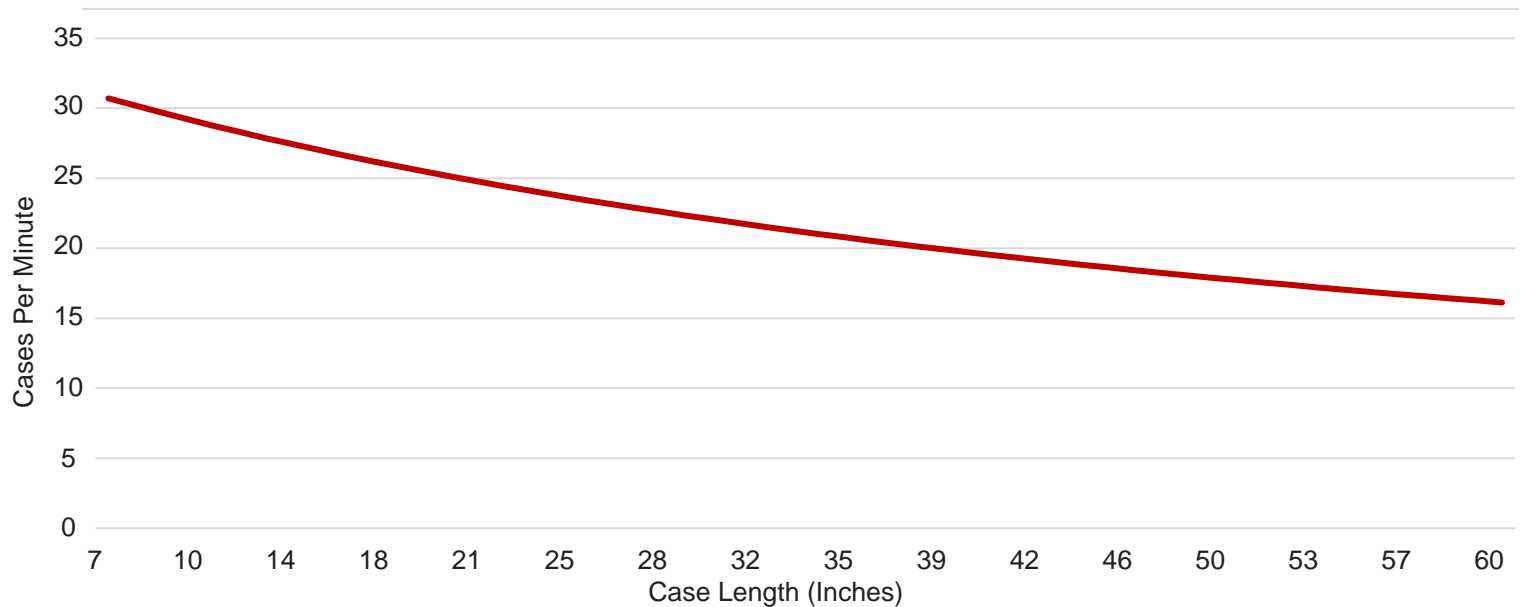
This machine comes standard with one main regulator. This regulator should be set to a maximum of 75 PSI (512.1 kPa).

Air must be clean and dry. If moisture enters the system valves can begin to degrade and lines slowly clog. This can cause reduced flow resulting in undesired machine behavior. If moisture is detected in the air lines an in-line air dryer may be used. IPG does not supply in-line air dryers.

## Operating Speed

Belt speed is variable but is factory set at 150 ft./min (45.7 m/min). Under some circumstances the belt speed may be slowed to provide optimal taping.

The below chart is based off of batch processing the same size case and optimal machine setup and setting. Actual throughput volume is dependent on case size mix and operator dexterity.



**Figure 23: Cases Per Minute**

# SPECIFICATIONS

## Tape Specifications

Use only **IPG Water-Activated Tape**. The machine can accommodate tape widths of 3 in. (70 - 75mm).

A maximum tape roll length of 4500 ft. (1371.6m) can be installed. This machine can accommodate all IPG brand, long roll water-activated tape.

The standard tape leg length of 3 in. (75mm) is factory set. The standard tape leg length may vary up to ¼ in. (6mm) based on tape tension and line speed.

The standard tape leg length is adjustable via the HMI. The minimum tape leg length recommended is 2 in. (48mm) and the maximum recommended is 3 in. (75mm).

## Operating Conditions

Use in a dry, relatively clean environment at 40° to 105° F (5° to 40° C) with clean dry cartons. Maximum sound pressure level is less than 70dBA.



**CAUTION: MACHINE SHOULD NOT BE WASHED DOWN OR SUBJECTED TO CONDITIONS CAUSING CONDENSATION ON COMPONENTS. FOLLOW CLEANING INSTRUCTIONS.**



**CAUTION: TO PREVENT INJURY KEEP AN AREA WITH A MINIMUM OF 36 IN. (915MM) OF SPACE CLEAR, CLEAN, AND DRY ON THE OPERATOR AND CONTROL BOX SIDES OF THE MACHINE.**

## Carton Specifications

### Type

- Regular Slotted Containers (RSC)
- Other styles may be processed. Consult factory.

### Material

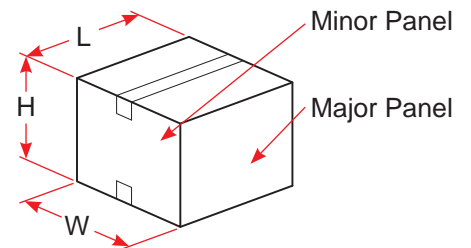
- 125 to 175 PSI bursting test, single or double wall, B or C flutes
- Other styles may be processed. Consult factory.

### Weight

- 0 to 38.5 kg (0 to 85 lbs.) Max

### Size

Carton Size	Length	Width	Height
Minimum	7" (178mm)*	7" (178mm)*	3.5" (89mm)
Maximum	Infinite	26" (661mm)	26" (661mm)



\*Minimum width may be adjusted to 6" (154mm), however, the maximum width will be limited to 25" (635mm).

However, if the box length (in the direction of the seal) to box height ratio is 0.75 or less, several boxes should be test run to assure proper machine performance. The formula is as follows:

$$\frac{\text{Carton Length in direction of seal}}{\text{Carton Height}} > 0.75$$

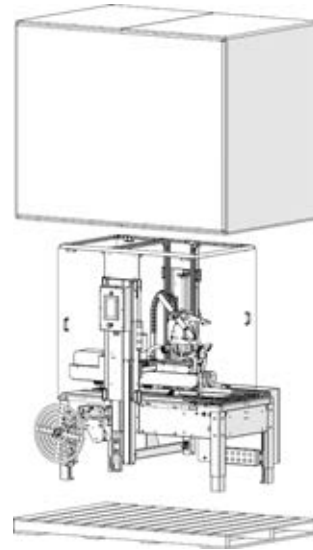
# SET-UP PROCEDURE

## Receiving and Handling

The Interpack **RSA 2626-WAT-TB Top Only** is shipped to the customer in a box and fixed to a pallet. The machine is enclosed with either a corrugated sleeve and cap or an HSC corrugated box. The sequence below is step by step instructions to remove all packing materials.

### **PRIOR TO SIGNING FOR THE MACHINE INSPECT IT FOR ANY DAMAGE THAT MAY HAVE OCCURRED DURING SHIPPING**

1. Remove the strapping and/or staples at the bottom of the box
2. Lift the box cover off of the machine, use caution and team lift
3. Remove any bubble wrap or protective wrapping
4. Inspect the machine for any damage that may have occurred during shipping
5. Remove the mounting bolts and nuts that secure the machine to the pallet
6. Using a forklift or other lifting device, lift the machine off the pallet
  - Install any optional casters at this point as well as adjusting leg height for desired conveyor height
7. Position the machine in its desired location
8. Remove any remaining tie wraps and shipping materials
9. Install the stacklight
10. Install any optionally ordered equipment



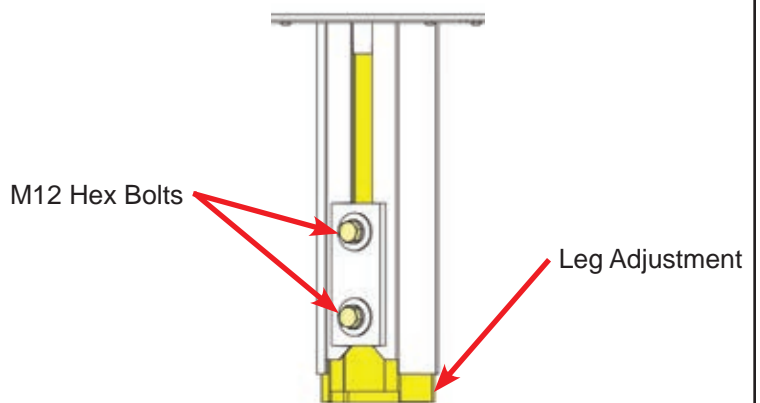
**Figure 24: Unboxing**

After unpacking the Case Sealer, look for any damage that may have occurred during shipping. Should the Case Sealer be damaged, file a claim with the transport company and notify your IPG representative as soon as possible.

## Set up

The Case Sealer must be installed on a near level ground. Use the adjustable legs to ensure the machine is level and firmly planted on the ground (no rocking). Adjust the leg height with the four (4) telescopic adjustment legs to accommodate conveyor heights from 24 in. to 30 in. Consult with the factory for any other conveyor heights that may be required. Optional Casters add 4 in. to the conveyor height. If noted in the purchase order the case sealer can be shipped pre-configured for the desired conveyor height.

To adjust the Case Sealer height, jack up the machine to give ample room to extend the legs. Using a 19mm box end wrench, loosen the eight (8) M12mm hex bolts. Adjust the legs to the desired conveyor height and tighten the bolts. Etched lines on the legs ease leveling. The machine must be properly supported prior to any leg adjustment.



**Figure 25: Leg Adjustment**

Customer supplied exit conveyor (if used) should be straight and declined no more than 1 in./yard (5 cm/meter) away from the Case Sealer to convey the sealed cartons away from the machine.

# SET-UP PROCEDURE

## Optional Equipment: Caster Installation



**WARNING: CASTER INSTALLATION REQUIRES RAISING THE MACHINE TO ACCESS THE BOTTOM OF EACH LEG. FOLLOW ALL POSSIBLE SAFETY PROCEDURES PRIOR TO AND DURING THIS PROCESS.**

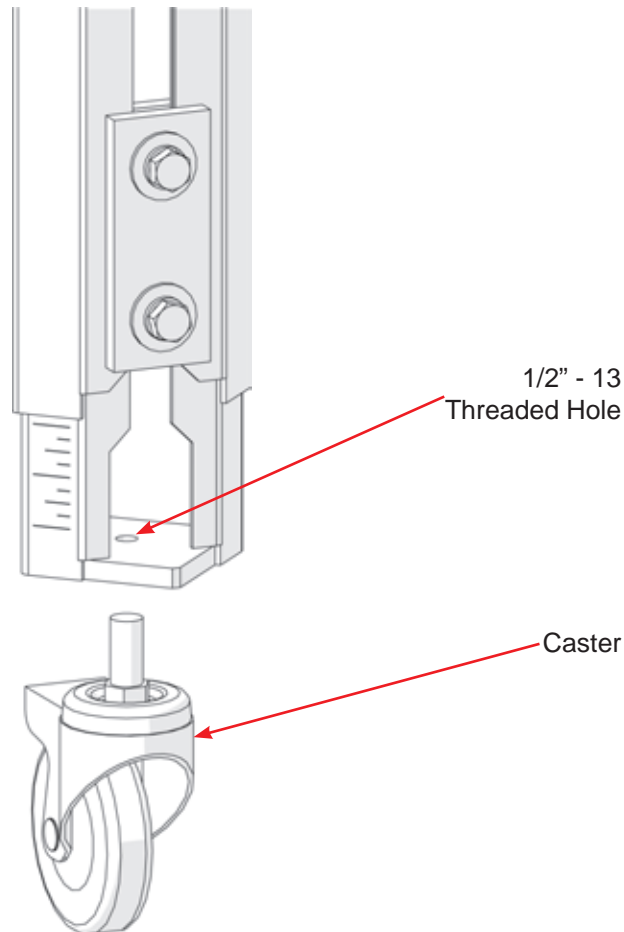
Be advised there are several ways to install the casters on IPG Case Sealers. Consult your company's safety practices after reading through the below directions. Take all precautions necessary.

1. Raise the machine to allow access to the bottom of each leg.
2. By hand, screw the caster into each leg.
3. Using a wrench, verify each caster is firmly seated to the bottom of the legs.
4. Lower the machine back down until it is resting on the casters.
5. Adjust the legs as necessary to achieve proper level of the machine.



**CAUTION: DO NOT ADJUST THE HEIGHT USING THE CASTERS. HEIGHT CHANGES ARE TO ONLY BE MADE BY ADJUSTING THE LEG EXTENSIONS.**

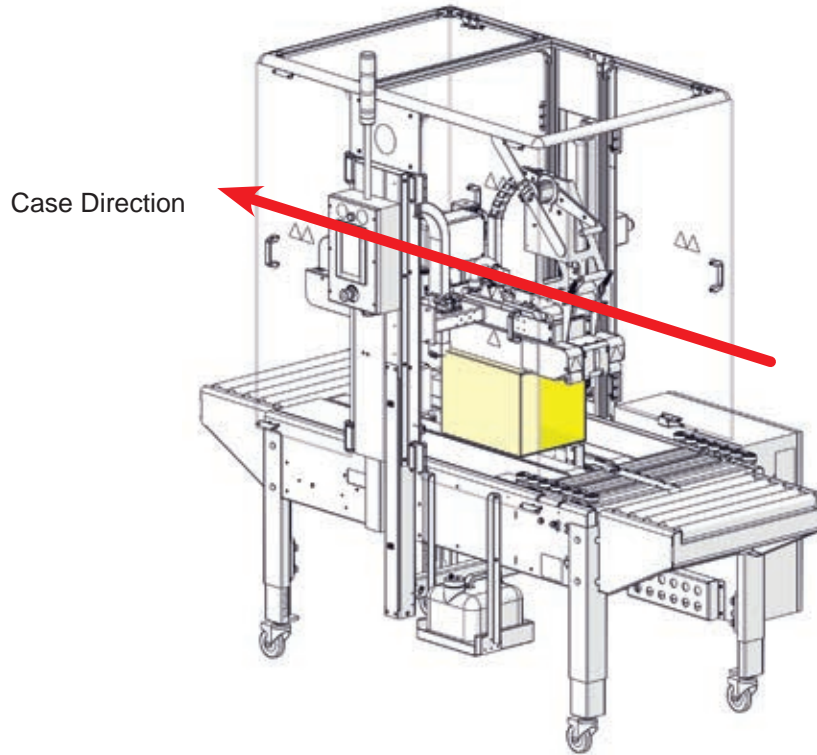
6. Position the machine in its desired location.
7. Lock the casters.



**Figure 26: Caster Installation**

# SET-UP PROCEDURE

## Optional Equipment: Infeed Table Installation

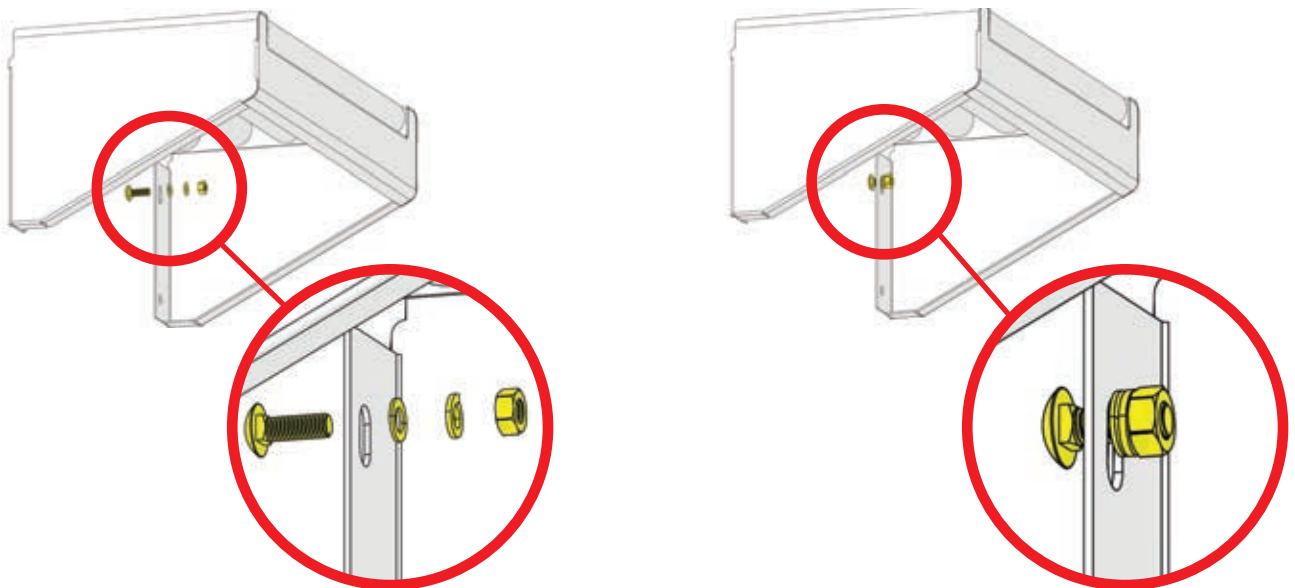


**Figure 27: Case Direction**

The RSA 2626-WAT-TB Top Only can accept an Infeed and/or Outfeed Table.

IPG Case Sealers come with the necessary mounting points for in-feed/out-feed tables. The optional in-feed/out-feed tables will come with all necessary hardware to mount to the machine. The case sealers can accept a variety of table sizes. Please consult with the factory on the best size table for your application.

1. Loosely install two carriage bolts into top two mounting holes on roller table with hardware included.

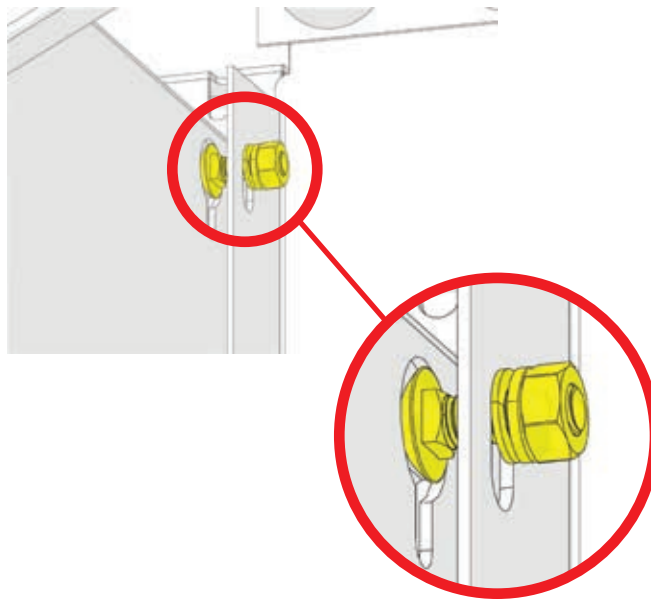


**Figure 28: Carriage Bolt Assembly**

# SET-UP PROCEDURE

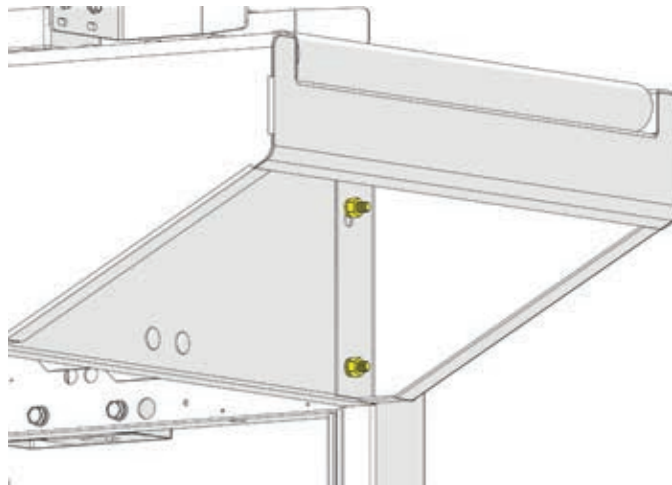
## Optional Equipment: In-feed Table Installation (Continued)

1. Utilizing the slots on the machine base, attach roller table to machine base by locating carriage bolts in slots on machine base and push down to lock in place. Make sure carriage bolts are properly aligned into the slot when pushed down to lock in place before proceeding.



**Figure 29: Table to Machine Base Installation**

2. Once roller table is attached to the machine base using the two carriage bolts, install remaining two carriage bolts with hardware included through the bottom two holes on the machine base and roller table.
3. After all four mounting studs and included hardware have been installed, tighten all hardware to avoid roller table instability then install rollers on table.



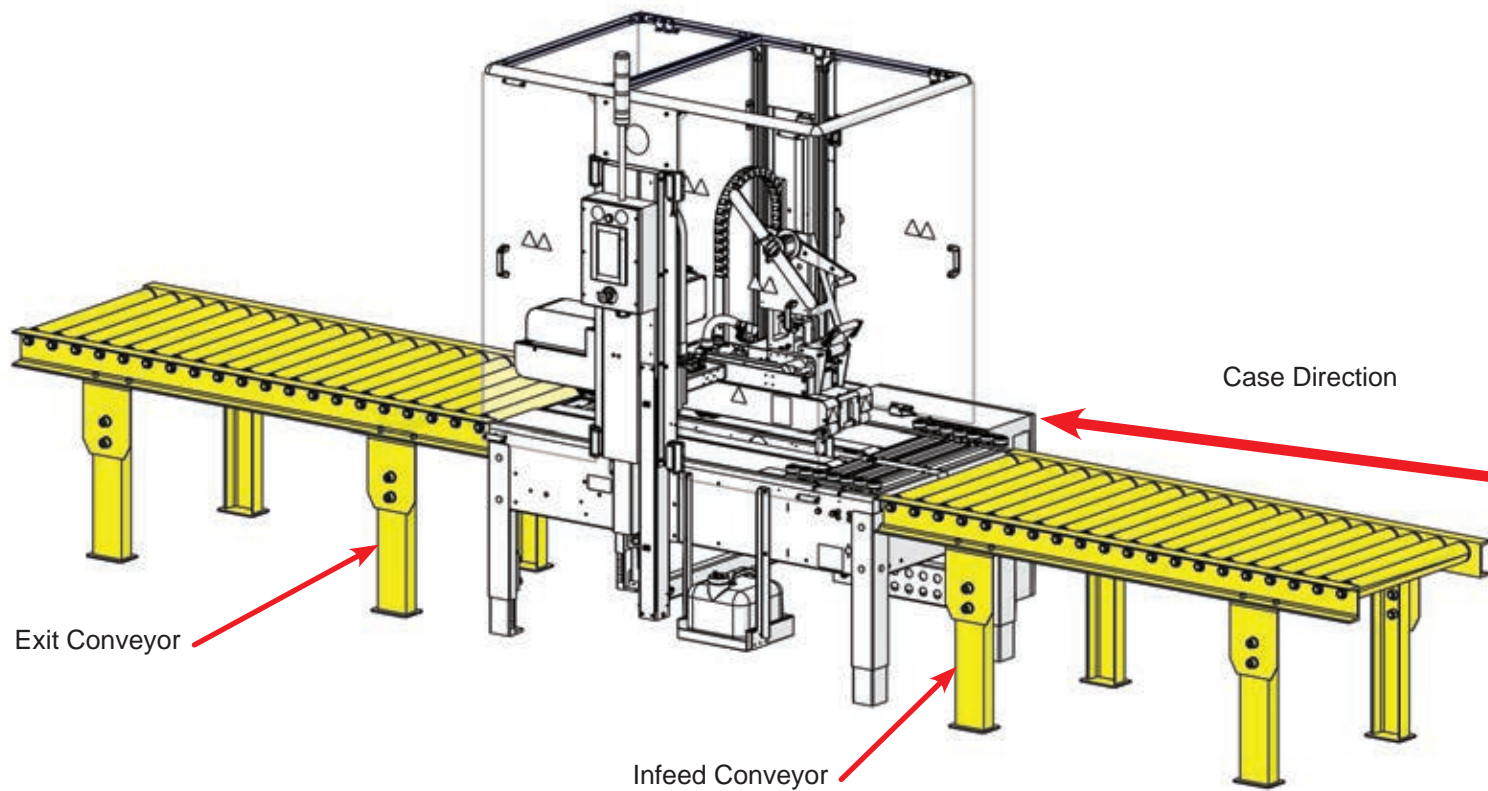
**Figure 30: Remaining Carriage Bolt Installation**

# SET-UP PROCEDURE

## Optional Equipment: Installation of External In-feed and Exit Conveyors

IPG does not supply conveyors. All conveyors are to be customer supplied.

1. Customer supplied gravity exit conveyor (if used) should be straight and declined no more than 1 in./yard (2.5 cm/meter) away from the machine to convey the sealed cartons away from the machine.
2. Customer supplied powered exit conveyor should be straight and level to convey the sealed cartons away from the machine.



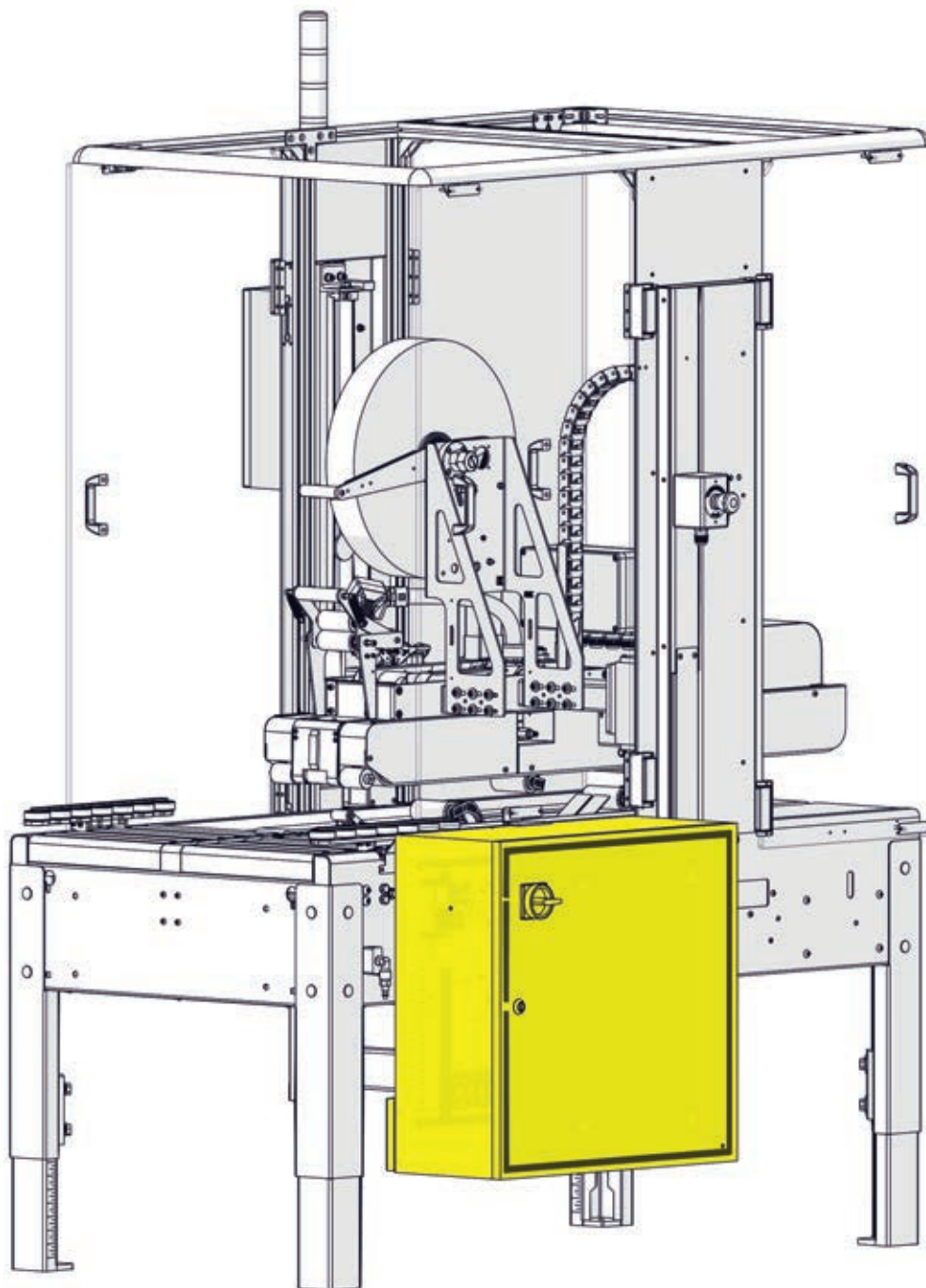
**Figure 31: Installing Exit Conveyors**

# CONNECTING UTILITIES

## Electrical Utilities

A 12 ft. (3.6m) standard three-conductor power cord with plug is provided for **110V, 60HZ, 15A** electric service. The receptacle must be properly grounded. Before the machine is plugged into the receptacle, ensure that all materials are removed from the machine. The electrical control is protected with an automatic circuit breaker with resettable overload and fuses. Do not use an extension cord or power-strip.

The electrical box is located on the right side of the **RSA 2626-WAT-TB Top Only** Case Sealer.



**Figure 32: Electrical Utilities**

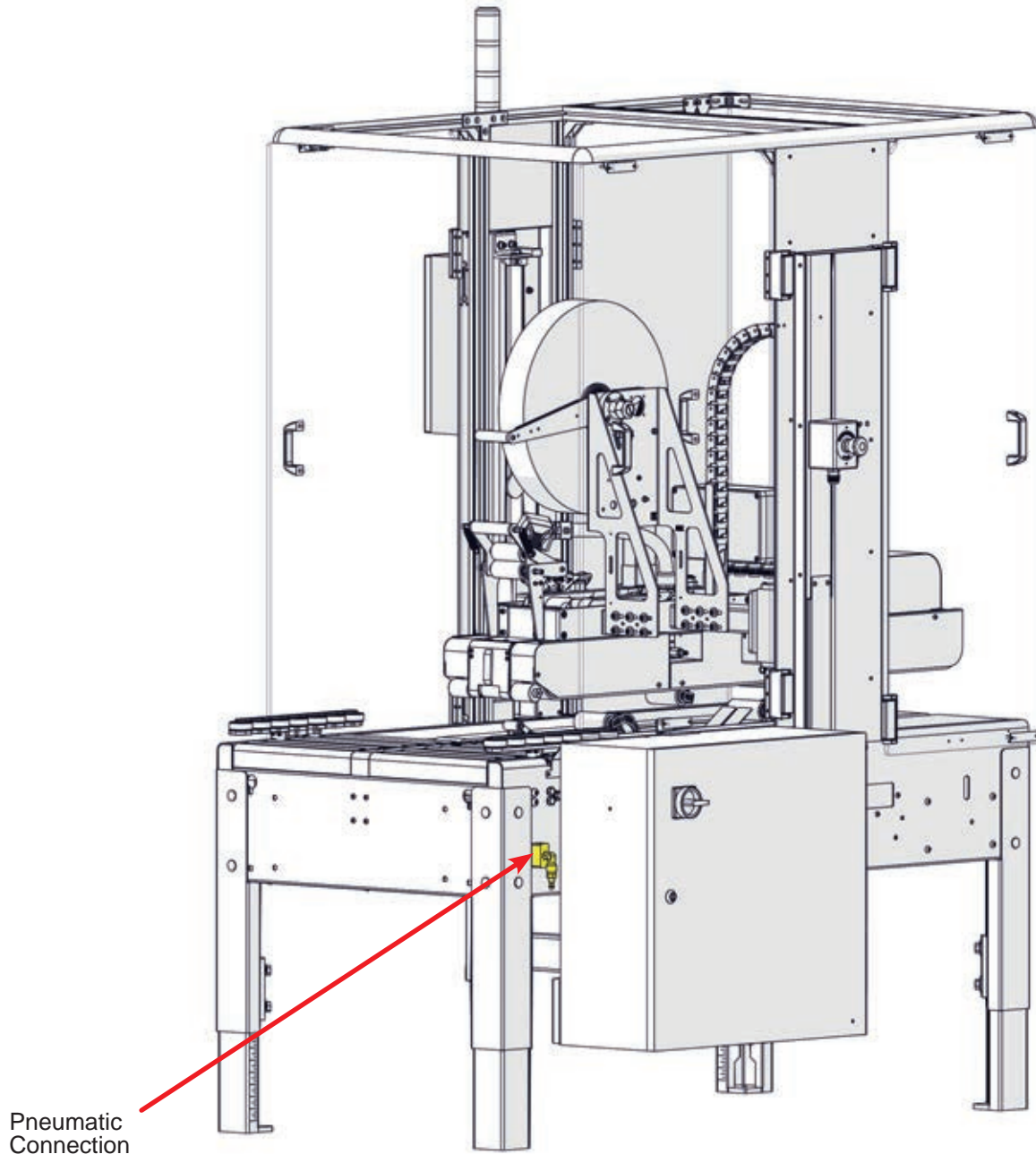
The electrical box and pneumatic input can be reversed but this is recommended to be done at the factory.

# CONNECTING UTILITIES

## Pneumatic Utilities

The pressure setting for the main air regulator is factory set. The values can be adjusted as needed by customer supplied pressure and volume.

The main air connection is located on the right side of the machine just past the front leg. Connect clean dry compressed air to this adapter. The **RSA 2626-WAT-TB Top Only Case Sealer** requires a minimum of **9 CFM at 100 PSI** (28.3 Liter/min at 689 kPa). This will supply air to the main regulator located inside the machine under the left cover.



**Figure 33: Pneumatic Utilities**

# CONNECTING UTILITIES

## Pneumatic Utilities Continued

The **main regulator** is located under the left stainless steel cover of the machine. It is supplied directly from the exterior air inlet. To regulate the main air pressure, pull on the knob located on the top of the main air regulator. Turn the knob clockwise for more pressure and counterclockwise for less. When the air pressure is at 90 PSI, push back down on the button until a “click” is felt to lock it in position.

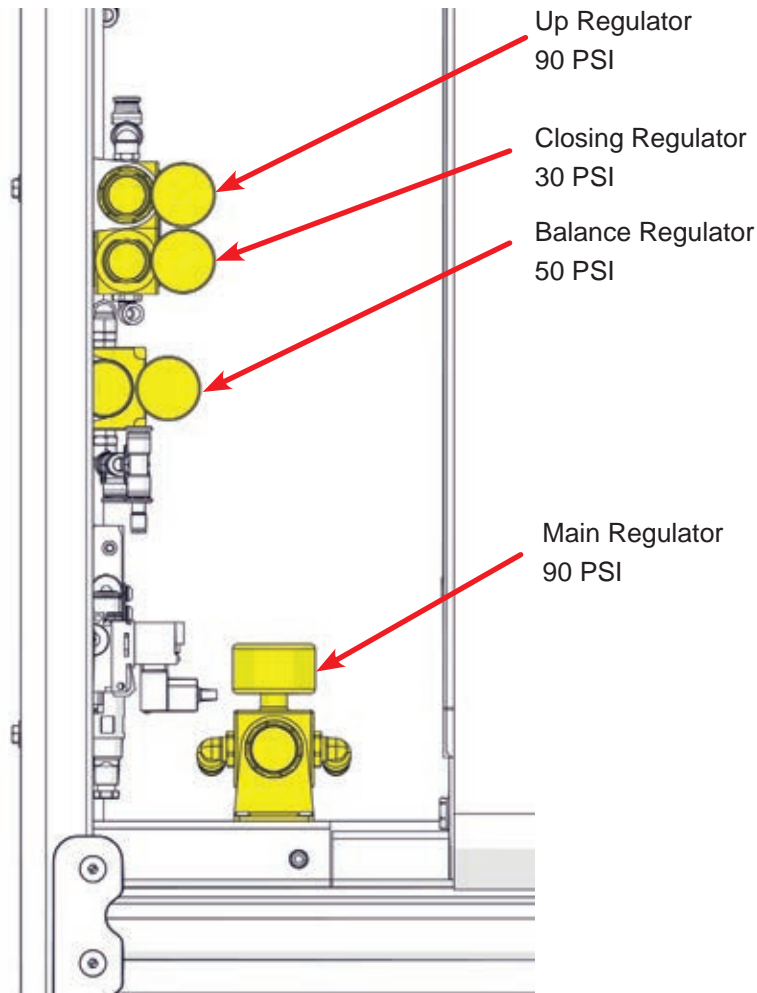
Should the supplied airline or pressure be unplugged, cut, or pressure drop for any reason, tape will not feed and rollers will not be activated if box is processed.

The **balance regulator** provides air to counter balance the weight of the bridge as it comes down onto a carton. Decreasing this pressure will increase the applied force onto the cartons as well as make the bridge drop faster. Pressure on this regulator should be set to 50 PSI. Small adjustments may be necessary to optimize case processing for your box suite.

The **closing regulator** controls the amount of force the centering guide rollers apply to the sides of the carton. From the factory this should be set to 30 PSI. Decreasing the pressure on this regulator will cause the centering guides to close with less force. If the pressure is set low the guides may not properly center heavier cartons. If the pressure is high the guides may damage the carton before it is processed.

The **up regulator** controls the amount of force used to raise the bridge when a carton is presented to the front paddle. From the factory this regulator should be set to 90 PSI. Decreasing the pressure on this regulator will cause the bridge to ascend slowly.

Bridge behavior is determined by both the up and balance regulators. Small adjustments to these two regulators can optimize machine performance for your particular box suite.



**Figure 34: Pneumatic Controls**

# OPERATOR CONTROLS

Make sure machine is connected to air supply of at least 100 PSI (660.5 kPa) and machine regulator is set at 90 PSI. The following describes the use of control box buttons:

1. **Reset button** - Used to reset machine after power up or to reset after all E-Stops have been cleared. This button will blink when the machine is not ready and will be solid when the machine is energized.
2. **HMI** - The HMI screen is main the source of interaction an operator will have with the machine. Start, stop, and manual machine functions are all done through the HMI.
3. **Emergency Stop** button - There are two physical Emergency Stop buttons, one on the control box and one on the opposite column. Opening any of the four doors will also act as an Emergency Stop.
  - In Auto Mode, de-energizes machine.
  - In Manual Mode, de-energizes machine.

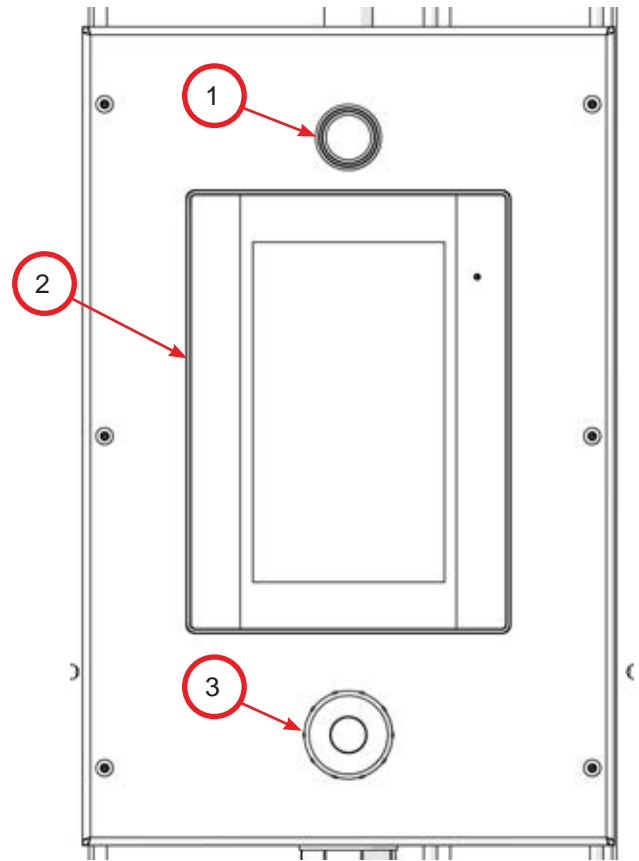


Figure 35: Operator Controls

## Emergency Stop Locations

Emergency stops are located on either side of the machine. Each of the doors are interlocked and tied into the safety circuit and will act as an emergency stop.

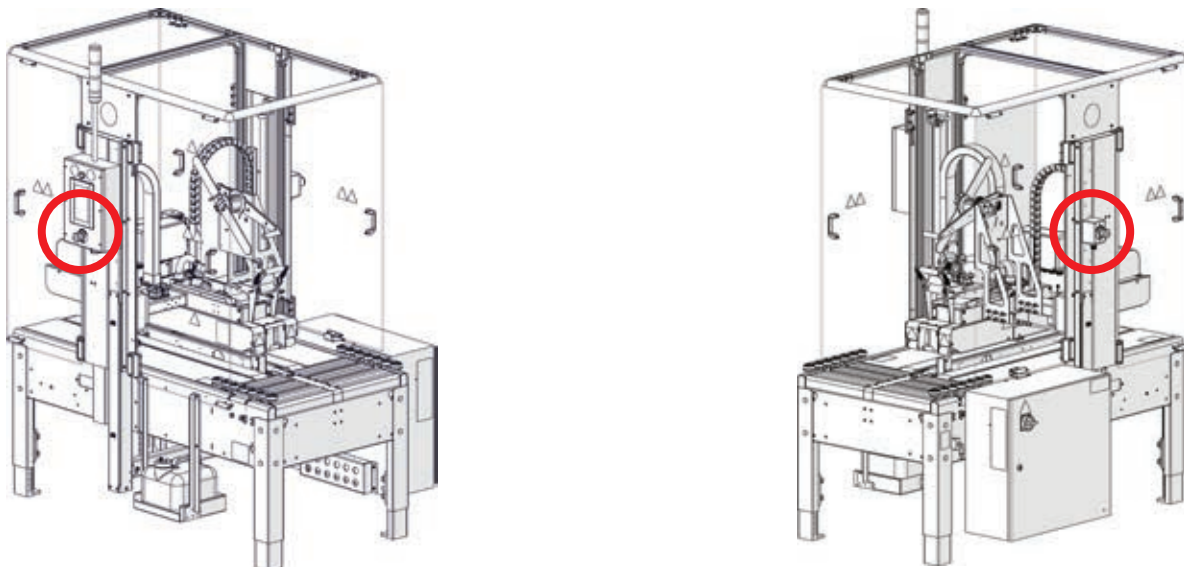


Figure 36: Emergency Stop Locations

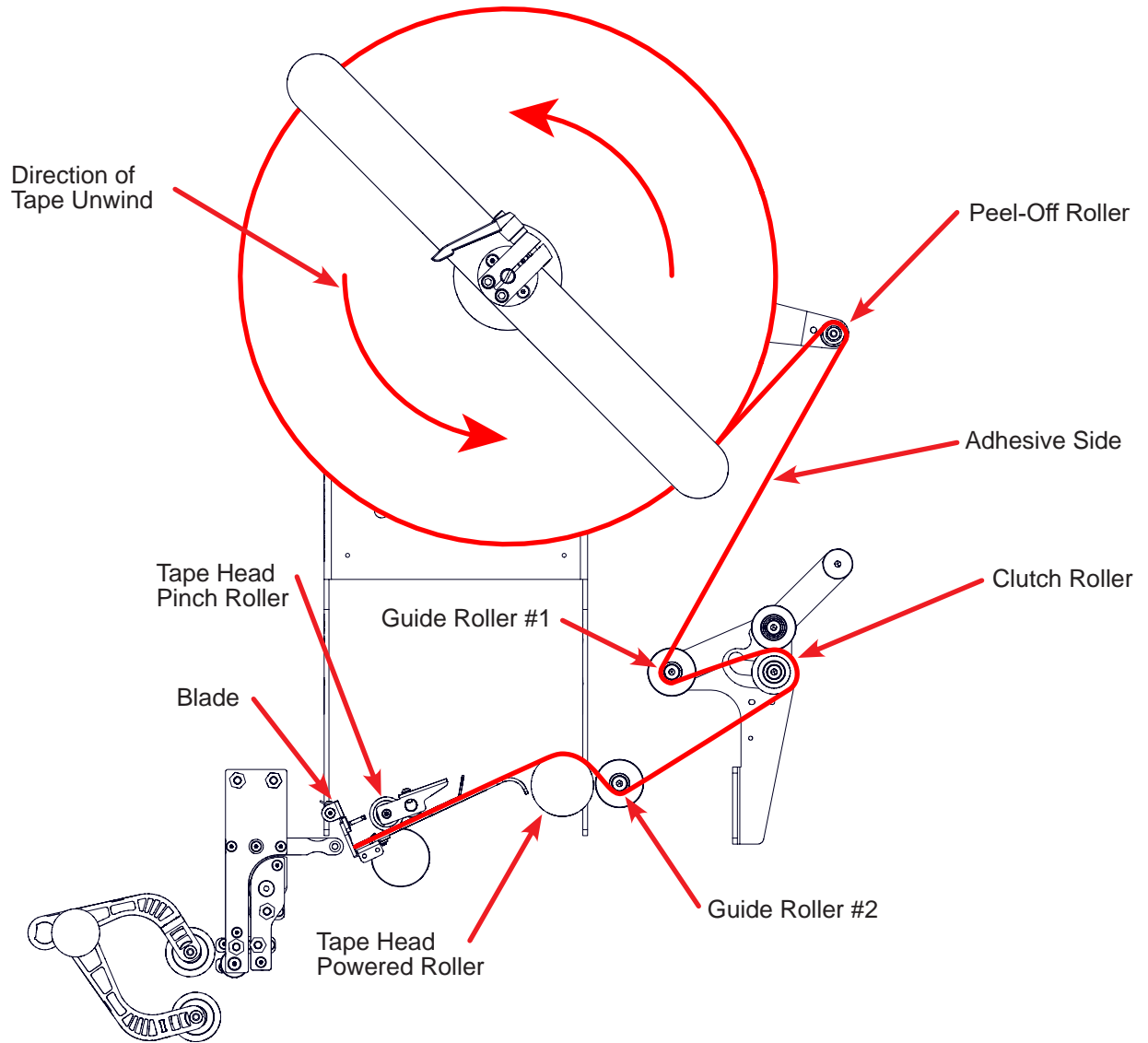
# TOP TAPE LOADING/THREADING

## Direction of Top Tape Unwind

As shown in the diagram below, tape should be mounted with a counterclockwise, unwind direction. The adhesive side of tape will be facing up as it goes around the peel-off roller.

## Top Tape Path

The diagram below shows the threaded tape path using the red line/arrow as the tape. For proper threading of tape use the steps in the following section.



**Figure 37: Top Tape Path**

# **TOP TAPE LOADING/THREADING**

---

## **Top Tape Loading/Threading Instructions**

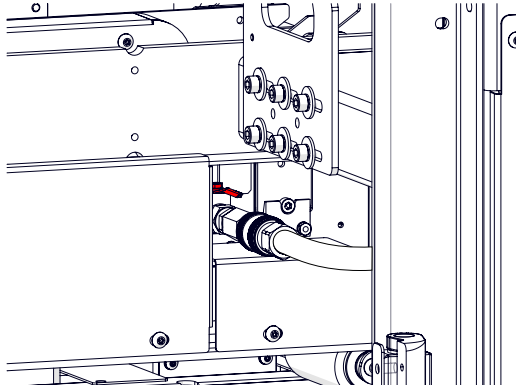
The instructions below will assist in threading tape on the top tape head.

1. Verify the bridge is in its home location and resting as low as it can be. If it is not clear any faults and navigate to the manual screen and flip the "Bridge" toggle switch to down.
2. Open the guarding door.
3. Loosen the handle on the cross bar assembly and remove it.
4. Remove the depleted tape core.
5. Install a new roll of tape. Be sure the unwind direction is counterclockwise.
6. Peel the tape off of the roll so it goes over the peel off roller. If the end of the tape is damaged in any way use a pair of scissors to cut a clean end.
7. Pull the tape to allow for slack it should go around the back of guide roller #1 with the adhesive side of the tape facing towards the infeed of the machine.
8. Unlock the clutch roller mechanism and pull the tape through between the two rollers.
9. The tape should then wrap around the clutch roller and underneath guide roller #2 before it enter the active taping mechanism.
10. Tape should be pulled over the powered roller and pushed under the pinch roller.
11. The end of the tape should come up to the blade but not touch it.
12. Reengage the clutch roller mechanism.
13. Close the door.
14. Clear all active faults and press the reset button.
15. Prime the active taping mechanism by navigating to the manual screen and select the Top Tape Feed.

# REMOVING/REPLACING THE TOP ACTIVE TAPING MECHANISM

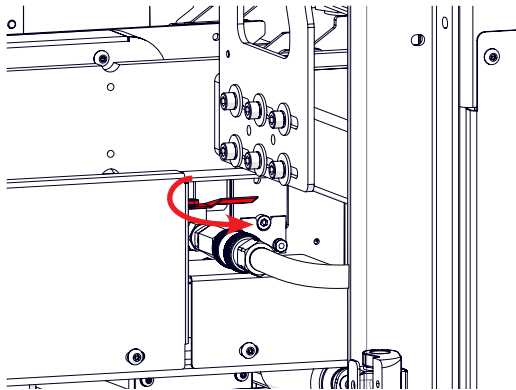
The tape mechanism contains the water pot, heater, motor, cutting assembly, and tape shoe. It is 22.5lbs (10.2kg). Use proper lifting techniques to reduce the risk of strain. Press the Emergency-Stop before removing.

1. Verify that the bridge is in its home position, as low as it can go.
2. Open the front right door to gain access.



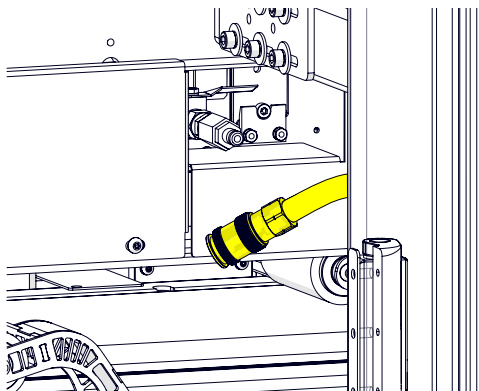
**Figure 38: Top Water Location**

3. Close the valve on the water pot. The hand should point toward the rear of the machine.



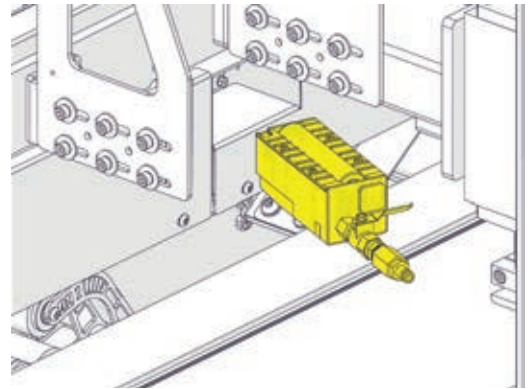
**Figure 39: Top Water Valve**

4. Disconnect the water supply using the quick disconnect.



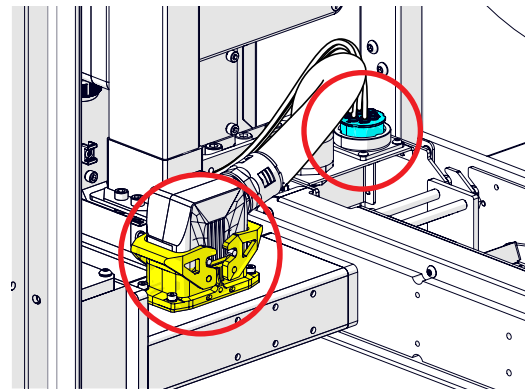
**Figure 40: Top Water Disconnect**

5. Remove the water pot from the taping mechanism. Place this in a nearby convenient location.



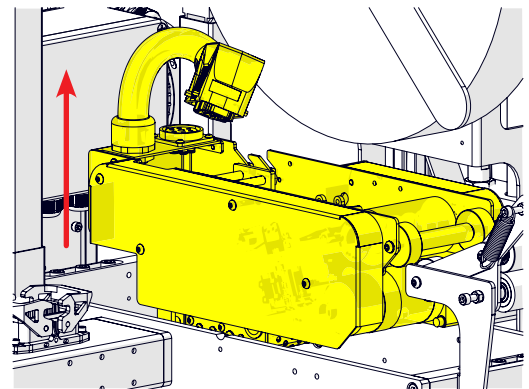
**Figure 41: Top Water Pot Removal**

6. Move to the other side of the machine.
7. Open the front left door to gain access.
8. Disconnect the locking clamps on the electrical supply connector to remove it. (Figure 45 Yellow)
9. Unscrew the pneumatic multi-line connector. (Figure 45 Blue)



**Figure 42: Top Energy Disconnect**

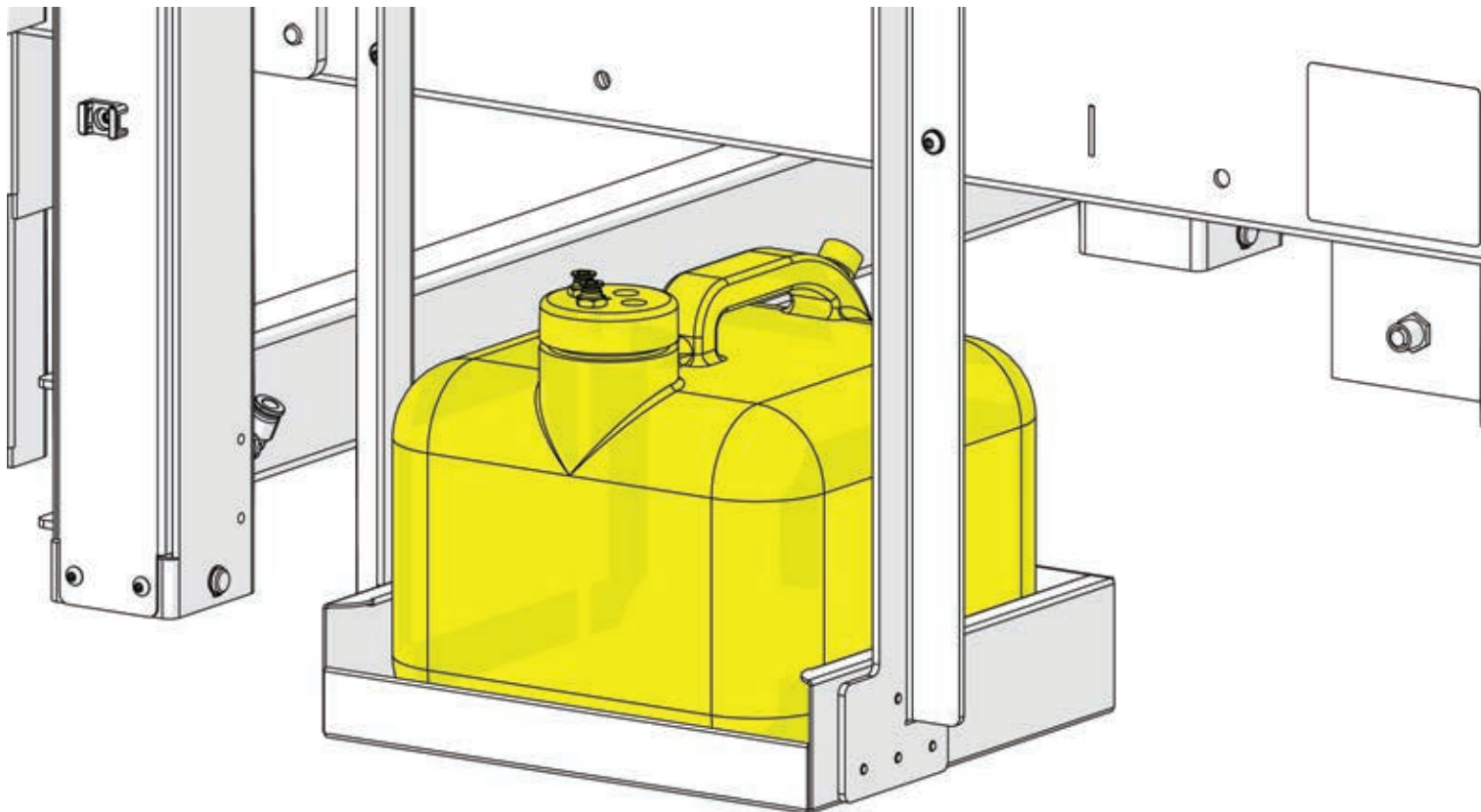
10. Lift the mechanism straight out of the bridge.



**Figure 43: Top Tape Mechanism Removal**

# ADDING WATER TO THE SYSTEM

The **RSA 2626-WAT-TB Top Only** comes equipped with a single high capacity water bottle. Water is distributed to the water feeder cups via a pump system. Water is fed to the feeder cups where water level is maintained by a cap where the pump will send water back to the water bottle. This provides a constant supply of clean water. Water is pushed through the red lines and pulled back through the blue lines.



**Figure 44: Water Jug**

Water is pushed through the red feed lines to the water cups and will fill them to the caps. The caps will maintain a consistent water level through the blue return lines to the water jug. This system supplies a consistent supply of water.

To replenish the water supply:

1. Remove the cap. Be sure the straws stay attached to the cap.
2. Remove the jug from the support.
3. Fill it with clean water.
4. Replace the jug on the support.
5. Feed the straws back into the jug and secure the cap.

# ADJUSTING THE WATER LEVEL

Depending on volume of cartons that are being processed through the RSA 2626-WAT-TB Top Only the water level may need to be adjusted. Water is transported from the water cups into the water pot through a gravity fed line. The water level is controlled by raising and lowering the water cup assemblies.

## Adjusting the top water level

1. To adjust the water level on the top loosen the four (4) M5 bolts on the water cup retainer.

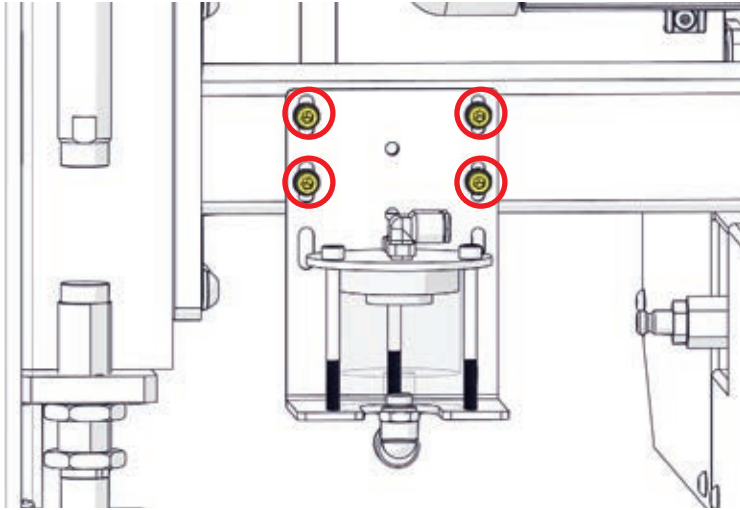


Figure 45: Top Water Level Adjustment 1

2. The water cup retainer has slotted holes allowing for it to slide vertically.
3. Shift the water cup retainer up to raise the water level in the water pot.
  - If the water level is raised all the way up some splashing may occur and can cause water to drip into the lower part of the machine.
4. Shift the water cup retainer down to lower the water level in the water pot.

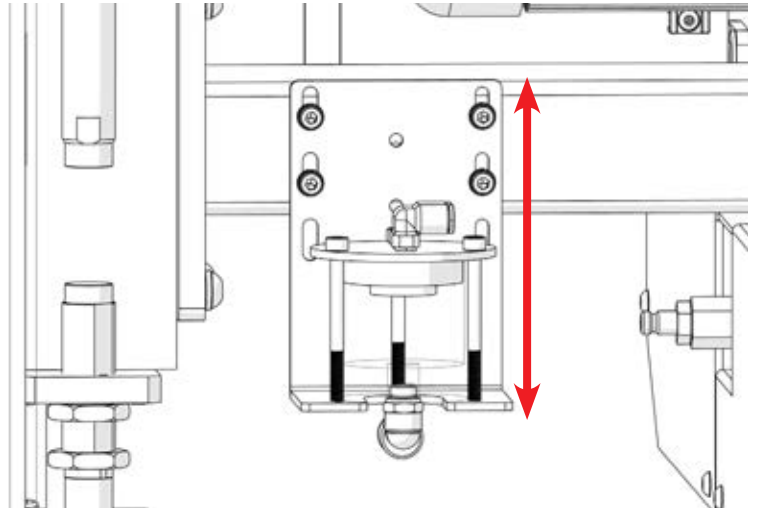
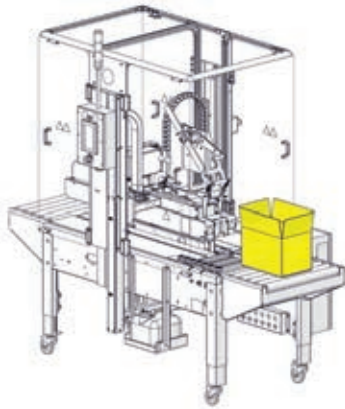


Figure 46: Top Water Level Adjustment 2

# CASE PROCESSING PROCEDURE

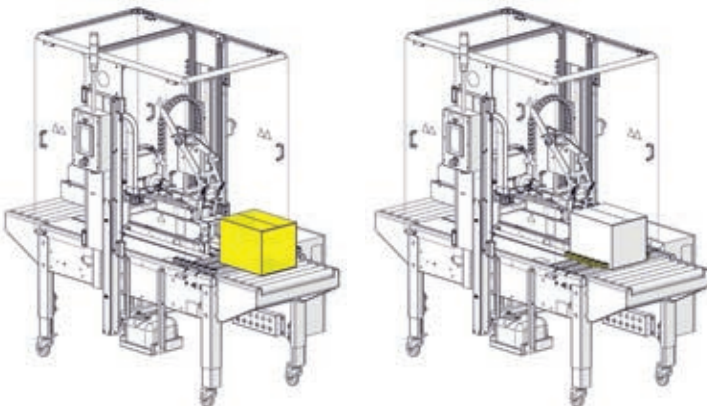
Setting up the **RSA 2626-WAT-TB Top Only** to process a case size is quick and easy. The machine will automatically adjust to cases that are being presented by operators.

1. The operator will need to close all flaps of the carton before it is processed through the case sealer.



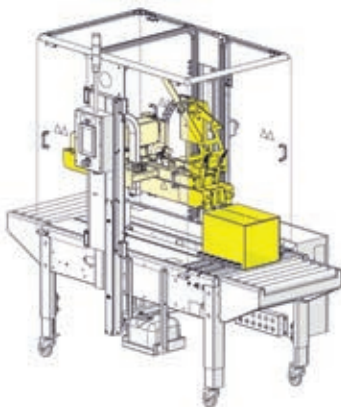
**Figure 47: Fold all Flaps**

2. The case can then be presented to the machine. When the centering photo-eye is blocked by the carton the centering guides will center the carton to the machine.



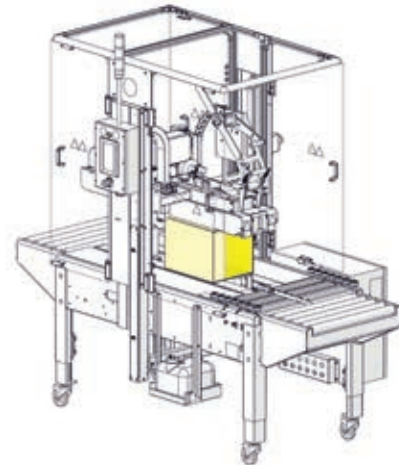
**Figure 48: Carton to Centering Guides**

3. The operator will then need to push the carton into the front paddle of the bridge. This will raise the bridge until the carton no longer presses against the front paddle.



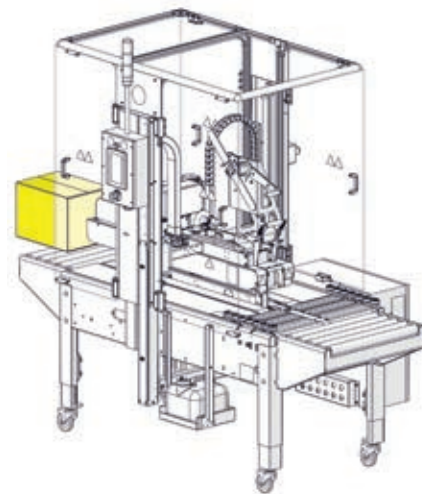
**Figure 49: Push Carton into Machine**

4. The operator will need to push the carton up to the gate.
5. The bridge will lower onto the top of the carton and the belts will pull the carton through the machine.



**Figure 50: Carton Processing**

6. While the carton is being processed a single strip of water activated tape will be applied to the center seam of the top of the carton.
7. When the carton has finished processing and exits the machine the bridge will return to its home position. After the carton exits a new carton can be processed.

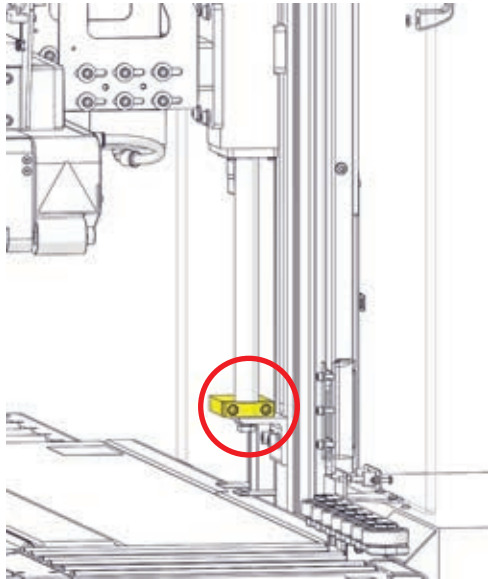


**Figure 51: Carton Exit**

# BRIDGE ADJUSTMENT PROCEDURE

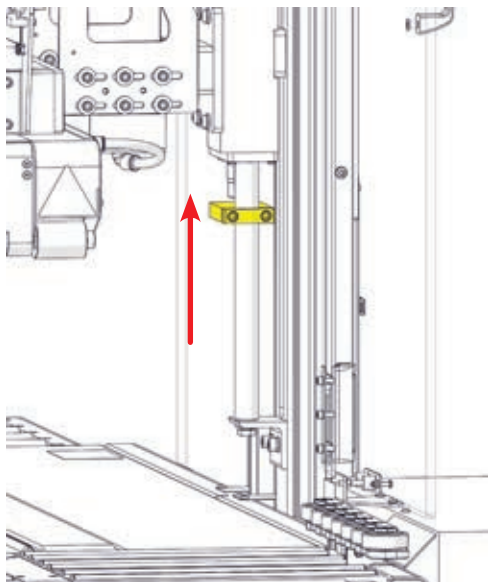
The **RSA 2626-WAT-TB Top Only** has the ability to set a new home location for the bridge. By doing this case processing time may be optimized for the minimum height carton in a box suite. This will modify the minimum processing height of the carton sealer. This can be modified at any time.

1. On the HMI navigate to the manual screen. Flip the “Bridge” switch to up.
2. On each of the column shafts a locking plate is located at the bottom of the column. Loosen the two (2) M6 screws.



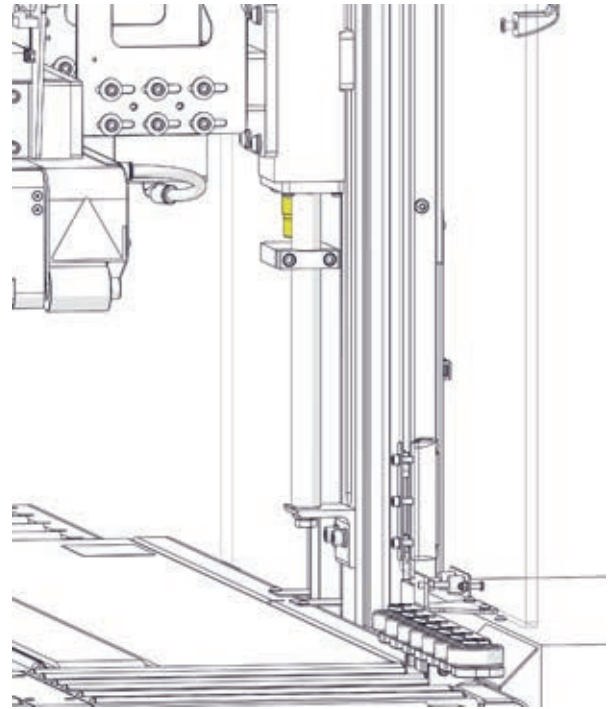
**Figure 52: Bridge Locking Plate**

3. Slide the locking plate to new desired location, then tighten the screws to lock it in place.



**Figure 53: Lifting the Locking Plate**

4. Repeat this process for the opposite column.
5. When both column locks are relocated and locked in position return to the HMI and navigate to the manual screen. Flip the “Bridge” switch to down. The bridge will then drop and the stoppers will rest against the locking plate and stop the bridge in the new position.



**Figure 54: Securing the Locking Plate**

# OPERATING INSTRUCTIONS

---

The following instructions are presented in the order recommended for processing cases through the **RSA 2626-WAT-TB Top Only** Case Sealer.

1. Install and thread tape on the machine (refer to the tape threading section).
2. Supply or connect the machine to 110V Electrical Supply (refer to Electrical Utilities).
3. Supply or connect the machine to Pneumatic Supply (refer to Pneumatic Utilities).
4. Verify that all Emergency-Stops are disengaged and doors are closed.
5. If not done so press the Reset Button (if engaged the Reset Button will be illuminated solid, otherwise it will be blinking).
6. On the HMI press the Green Start button to begin machine operation.
7. The operator will need to manually fold all the carton's flaps.
8. The operator should present the carton to the machine.
9. When the closing sensor is tripped the centering guides will automatically close to center the case.



**WARNING: ENSURE THAT THE OPERATOR'S HANDS ARE AWAY FROM THE CONTACT AREA BETWEEN THE BOTTOM OF THE CARTON AND THE MOVING BELTS AND CENTERING GUIDES. OPERATORS SHOULD GRIP THE CASE AT THE TOP REAR AND LET GO ONCE THE MACHINE HAS TAKEN THE CASE. IMPROPER HANDLING CAN LEAD TO INJURY.**



**WARNING: KEEP HANDS, HAIR, LOOSE CLOTHING, AND JEWELRY AWAY FROM MOVING BELTS, CENTERING GUIDES, AND TAPE HEADS**



**WARNING: KEEP HANDS AND OTHER BODY PARTS CLEAR OF THE BOTTOM OF THE MACHINE BRIDGE. THIS MAY POSE A MINOR CRUSH HAZARD.**

10. The operator will then need to push the carton into the front paddle on the bridge. This will cause the bridge to rise.
11. When the bridge clears the top of the carton the operator can push the carton into the machine.
12. The bridge will automatically start to descend when the front paddle is no longer pressed.
13. The gate will drop and the carton will process.
14. Once the carton has passed the gate, the gate will immediately return to home position preventing a second carton from entering the machine.
15. While a carton is being processed the front paddle will be locked out preventing a second carton from entering the machine prematurely and disrupting the taping routine.
16. Once the carton has finished being processed and exits the machine the bridge will drop to its home position. The machine can now process the next box.

When feeding cartons into the Case Sealer all flaps must be closed prior to entering the machine. Be sure that all cases are fed squarely and straightly into the Case Sealer, feeding cases crooked can result in poor seals and/or case jams.

In the event of a case jam follow the Carton Jam Procedure. Do not attempt to clear a jam while the case sealer is on.

# OPERATING INSTRUCTIONS

---

## Carton Jam Clearing



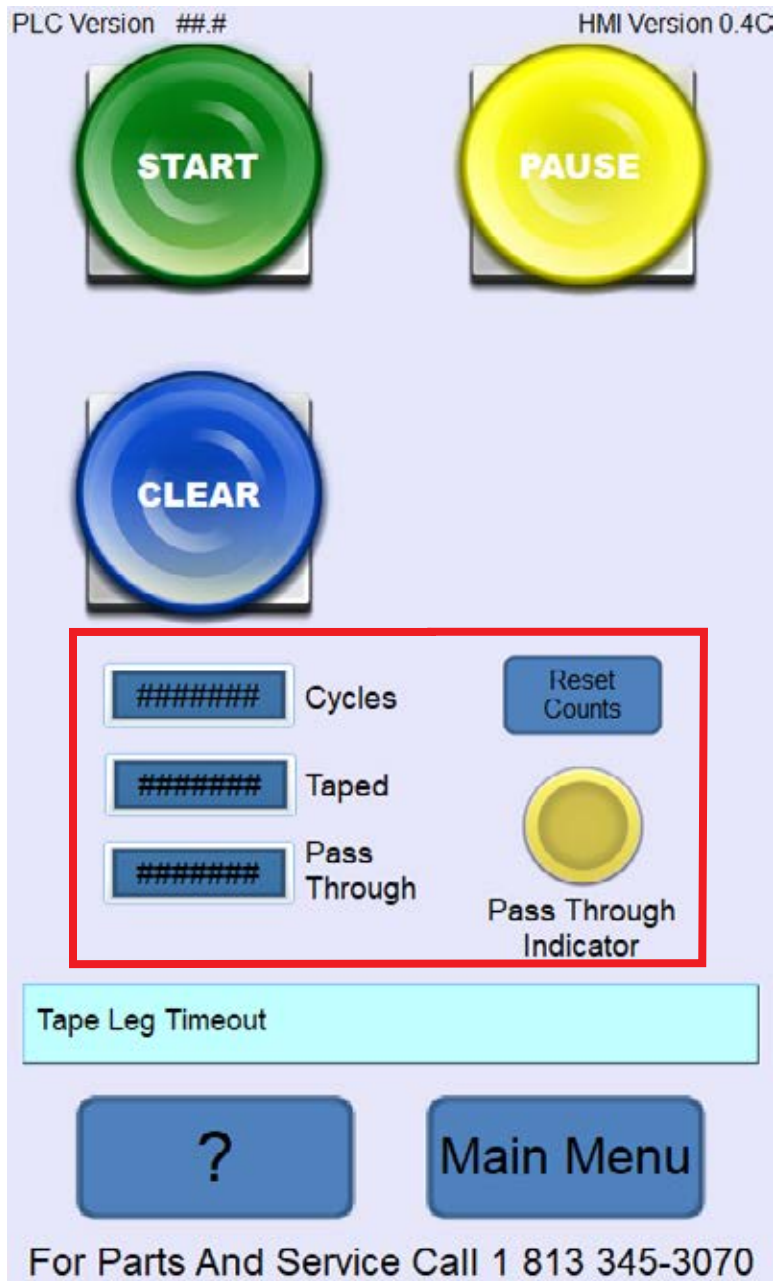
**WARNING: DO NOT ATTEMPT TO REMOVE ANY JAMMED CASE FROM A CASE SEALER THAT IS CURRENTLY ON. DO NOT ATTEMPT TO PUSH A JAMMED CASE THROUGH THE MACHINE. THE MACHINE HAS COMPONENTS UNDER PNEUMATIC PRESSURE. NOT FOLLOWING THE PROPER CASE JAM CLEARING METHODS CAN RESULT IN INJURY.**

The **RSA 2626-WAT-TB Top Only** has an adjustable jam timer that can detect most carton jams automatically. When a jam is detected the belts will stop and if tape has been dispensed it will automatically be cut.

1. After the case sealer stops the operator should read the error message on the HMI.
2. The operator should press the “Clear” button on the HMI.
  - This action will cause the case sealer’s bridge to raise up all the way and cut any tape that has been dispensed. When these actions are completed the case sealer will dump the air from the system discharging any stored pneumatic energy.
3. The operator can now open the appropriate door of the case sealer that allows for the safest removal of the carton.
  - This action will interrupt the safety circuit and act identically as an emergency-stop press. This will stop the flow of power to many systems and place the case sealer in a low energy state. Some elements inside the electrical cabinet will remain powered including the PLC and HMI.
4. The operator should remove the jammed carton and any dispensed tape from the machine.
5. The operator should follow any plant procedures and policies on how to inspect and reprocess the material that was inside the jammed case.
6. The operator can now close any doors that were opened and disengage any emergency-stop buttons that may have been pressed.
7. Pressing the blue “Reset” button on the operator control box will return air pressure and power to all elements of the case sealer. The case sealer will now be in a state that is ready to use.
8. The operator should then navigate to the “Manual Screen” on the HMI.
9. Pressing the “Tape Feed” button will dispense a small amount of tape from the top and/or bottom mechanisms. This will ensure the tape path is clear and prime the mechanisms for the new carton.
10. The operator will need to remove the dispensed tape before processing any new cases.
11. If the operator opens any doors in the process they will need to press the blue “Reset” button again before continuing.
12. To return to normal operation the operator will press the “Start” button on the HMI. This will cause the bridge to return to its home position.
13. The case sealer is now ready to accept a new case for processing.

# HMI WINDOW EXPLANATIONS

## Main Screen



<b>START</b>	Pressing this will put the case sealer into Auto Mode and will tape cases presented to the case sealer.
<b>PAUSE</b>	Pressing this will stop the belts and put the case sealer into Manual Mode. This will interrupt the taping process.
<b>CLEAR</b>	Pressing this will automatically raise the bridge to its maximum position, cut any dispensed tape, and dump air from the case sealer. This will interrupt the taping process.
<b>RESET COUNTS</b>	Pressing this will reset the Cycles, Taped, and Pass Through counts.
<b>PASS THROUGH INDICATOR</b>	This will illuminate when the case sealer has entered Pass Through Mode.
<b>CYCLES</b>	Displays the number of cases that have entered the case sealer.
<b>TAPED</b>	Displays the number of successfully taped cases that have exited the case sealer.
<b>PASS THROUGH</b>	Displays the number of items that have been processed through the case sealer while in Pass Through Mode.
<b>?</b>	Pressing this will bring up the Help Menu.
<b>MAIN MENU</b>	Pressing this will bring up the Main Menu navigation.

**Figure 55: HMI Main Screen**

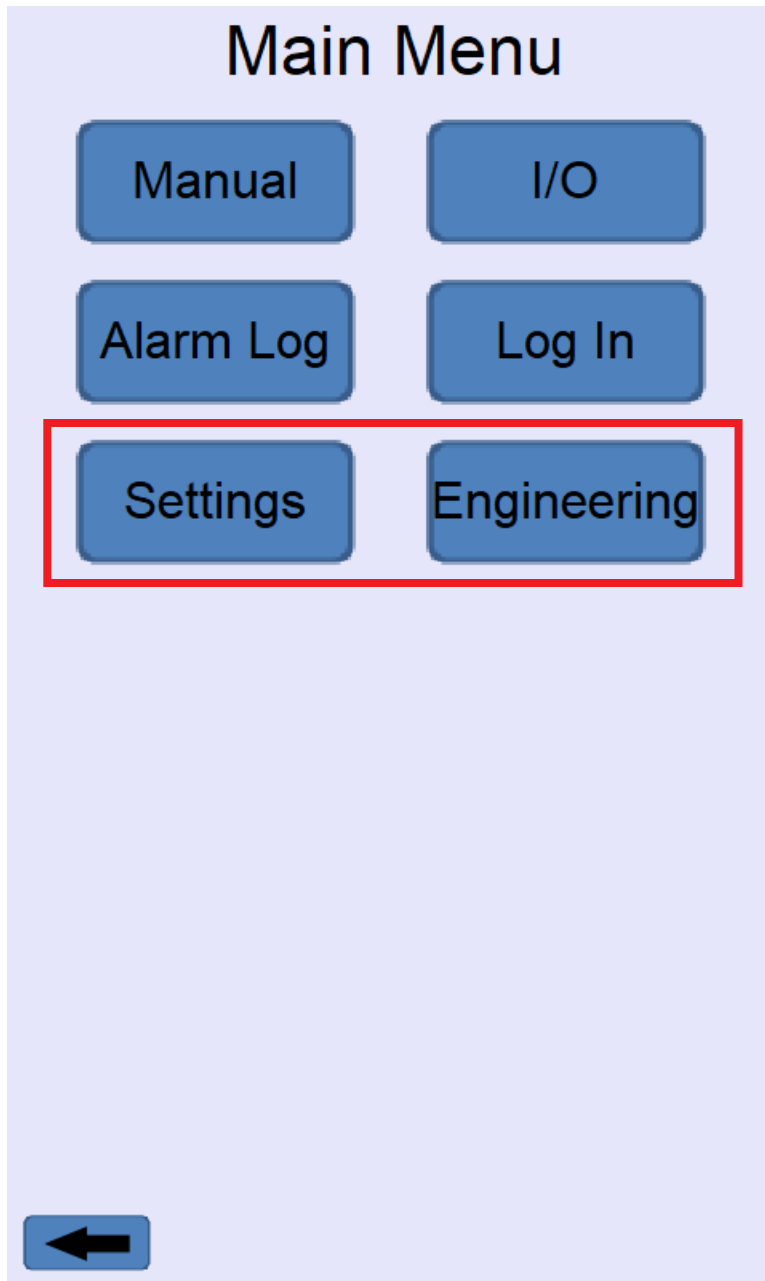
This is the Home screen of the HMI that is available to all users of the machine. If an error is not easily identifiable it will display on this screen. The "Start," "Pause," "Clear," "?," and "Main Menu" buttons are available to all operators.

Items highlighted in red can be displayed on the main screen selectively through the "Display Settings" screen accessible through the "Maintenance" level login.

Top only equipment may have a slightly different HMI appearance where items related to the bottom sealing may not be visible.

# HMI WINDOW EXPLANATIONS

## Main Menu Screen



<b>MANUAL</b>	Pressing this will put the case sealer into Manual Mode and bring the operator to the Manual Screen.
<b>I/O</b>	Pressing this will bring the operator to the I/O Screens.
<b>ALARM LOG</b>	Pressing this will bring the operator to the Alarm Log Screen.
<b>LOG IN</b>	Pressing this will bring the operator to the Log In Screen.
<b>SETTINGS</b>	When an advanced user is logged in pressing this will take the operator to the Setting Screens.
<b>ENGINEERING</b>	When an engineering user is logged in pressing this will take the operator to the Engineering Screens.
<b>BACK ARROW</b>	Will return to the home screen.

**Figure 56: HMI Menu Screen**

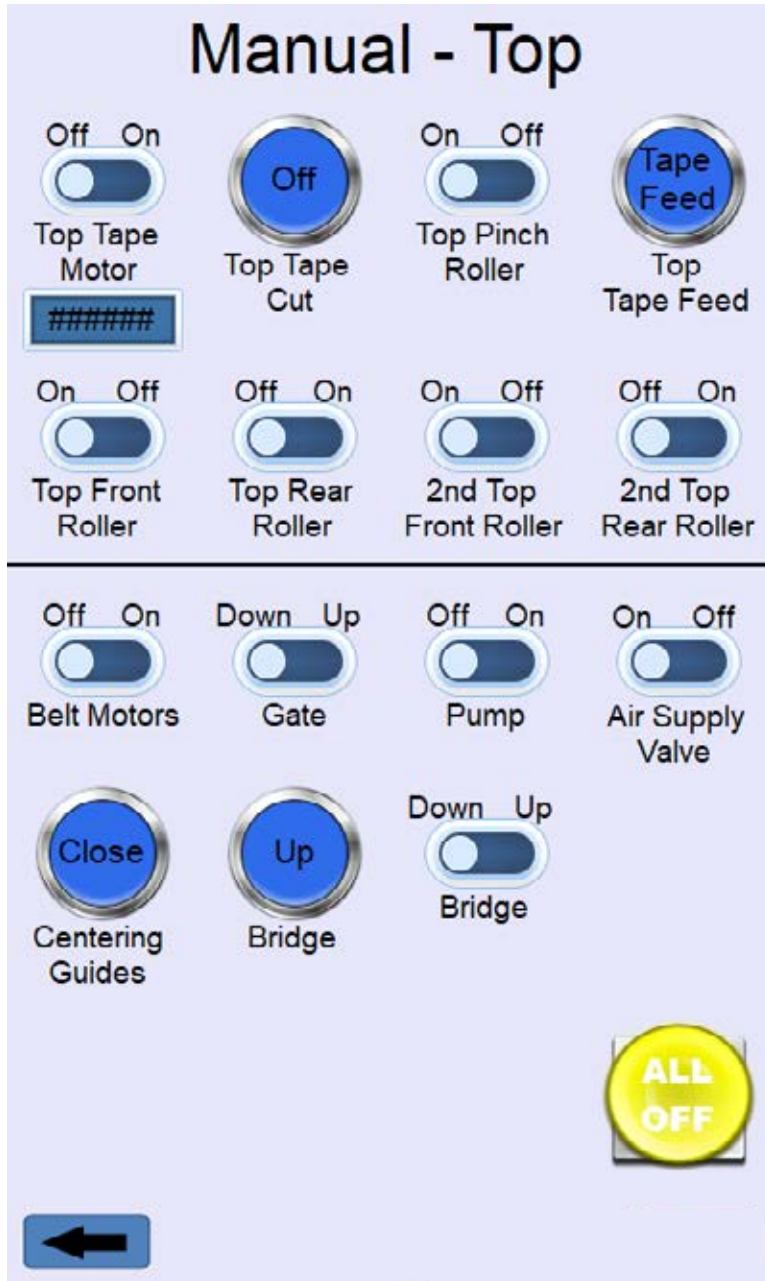
This is the Main Menu screen and is available to all users of the machine. It is accessible from the Home screen. It allows users to access the "Manual," "I/O," "Alarm Log," and "Log In" pages.

Items highlighted in red can be displayed on the Main Menu are only available for higher level users. The "Settings" screen is available to Maintenance and Engineering users. The "Engineering" screen is only available for Engineering users.

Top only equipment may have a slightly different HMI appearance where items related to the bottom sealing may not be visible.

# HMI WINDOW EXPLANATIONS

## Manual Screen



<b>TAPE MOTOR</b>	Pressing this will toggle on/off the taping motor selected.
<b>TAPE CUT</b>	Pressing this will engage the selected tape cutting mechanism.
<b>PINCH ROLLER</b>	Pressing this will toggle the selected pinch roller to engage/disengage.
<b>TAPE FEED</b>	Pressing this will execute the selected tape feed routine.
<b>FRONT ROLLER</b>	Pressing this will toggle the selected front arm actuator.
<b>REAR ROLLER</b>	Pressing this will toggle the selected rear arm actuator.
<b>2ND FRONT ROLLER</b>	Pressing this will toggle the selected 2nd front arm actuator.
<b>2ND REAR ROLLER</b>	Pressing this will toggle the selected 2nd rear arm actuator.
<b>BELT MOTORS</b>	Pressing this will toggle the belt motors on/off.
<b>GATE</b>	Pressing this will toggle the gate actuator down/up.
<b>PUMP</b>	Pressing this will toggle the water pump on/off.
<b>AIR SUPPLY VALVE</b>	Pressing this will toggle the dump valve on/off.
<b>CENTERING GUIDES</b>	Pressing this will close the centering guides. This is a momentary action and the guides will return to their home position when released.
<b>BRIDGE</b>	Pressing this will raise the bridge. This is a momentary action and the bridge will return to its home position when released.
<b>BRIDGE TOGGLE</b>	Flipping the toggle to "Up" will force the bridge to the maximum position and hold it there.
<b>ALL OFF</b>	Pressing this will return all items on all manual pages to their off positions.
<b>BACK ARROW</b>	Pressing this will return the operator to the Main Menu Screen.

**Figure 57: HMI Manual Screen**

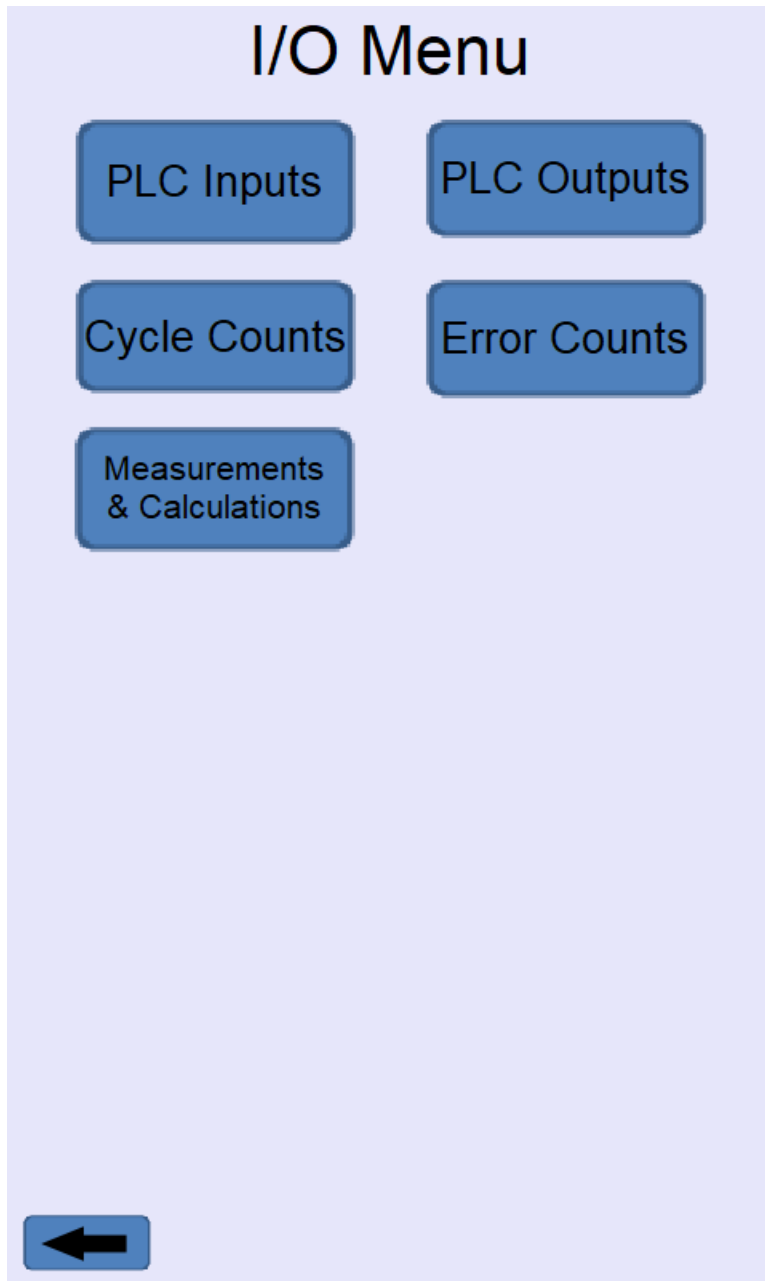
This is the Manual screen and is available to all users of the machine. It allows for manual control of parts of the machine. It defaults to controlling the top taping mechanism where an operator can turn on/off the tape motor, actuate the cutting mechanism, turn the pinch roller on/off, start a tape feed routine, and control each of the four (4) wipedown arms. Going into this screen will turn off the automatic taping of the machine.

The lower half of the screen allows for the control of general machine functions. Turn the belt motors on/off, actuate the gate, turn the water pump on/off, turn the air supply to the machine on/off, move the bridge up/down. The "Close" button will close the centering guides when pressed and open them when released. The "Up" button will raise the bridge for as long as it is held and will drop it when let go.

The "All Off" button will return all switches to their nominal and default settings.

# HMI WINDOW EXPLANATIONS

## I/O Menu Screen



<b>PLC INPUTS</b>	Pressing this will take the operator to the PLC Inputs page.
<b>PLC OUTPUTS</b>	Pressing this will take the operator to the PLC Outputs page.
<b>CYCLE COUNTS</b>	Pressing this will take the operator to the Cycle Counts page.
<b>ERROR COUNTS</b>	Pressing this will take the operator to the Error Counts page.
<b>MEASUREMENTS &amp; CALCULATIONS</b>	Pressing this takes the operator to the Measurements & Calculations Screen.
<b>BACK ARROW</b>	Pressing this will return the operator to the Main Menu Screen.

**Figure 58: HMI I/O Menu Screen**

This is the I/O Menu and is available to all users of the machine. It allows the user to navigate to the PLC Inputs, PLC Outputs, Cycle Counts, and Error Counts screens.

Top only equipment may have a slightly different HMI appearance where items related to the bottom sealing may not be visible.

# HMI WINDOW EXPLANATIONS

## PLC Inputs Screen



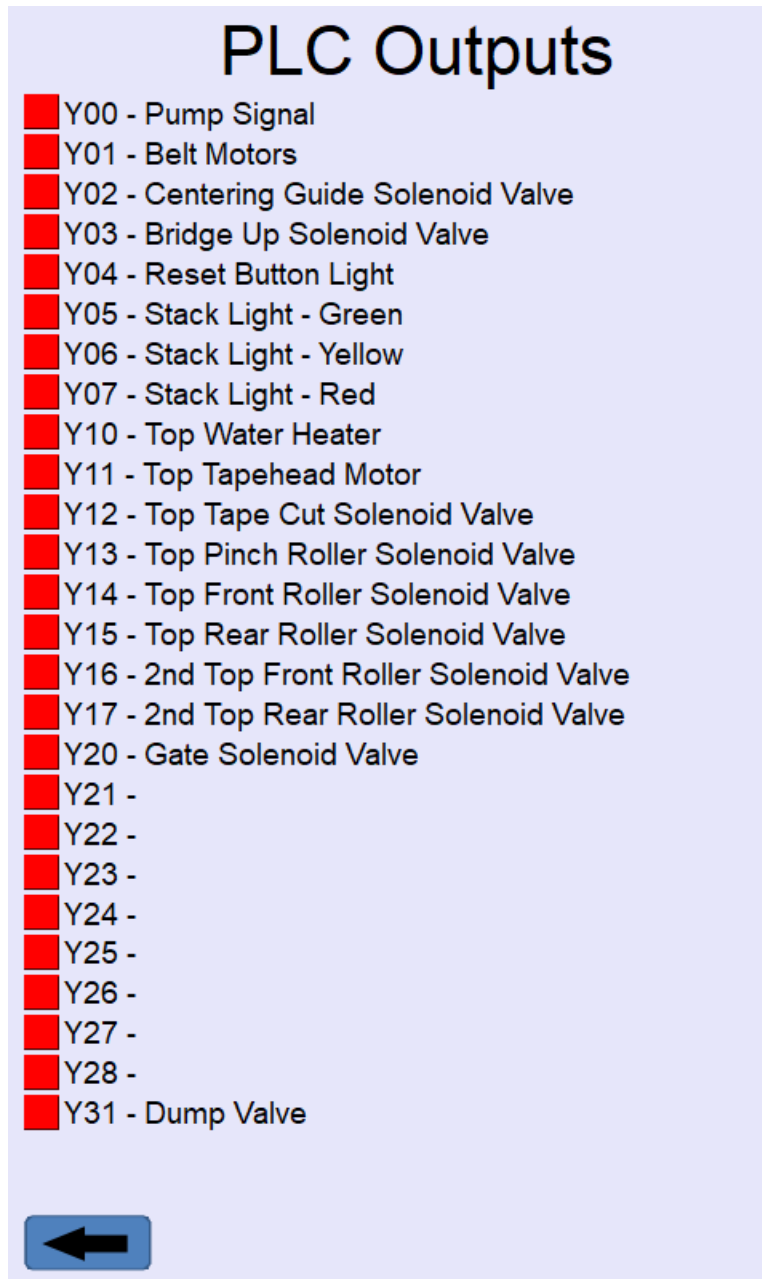
**Figure 59: HMI PLC Input Screen**

This is the PLC Inputs screen and is available to all users. This screen will show all active and inactive inputs on the PLC. Active inputs will have a green box while inactive will be red. This screen is helpful for troubleshooting.

Top only equipment may have a slightly different HMI appearance where items related to the bottom sealing may not be visible.

# HMI WINDOW EXPLANATIONS

## PLC Outputs Screen



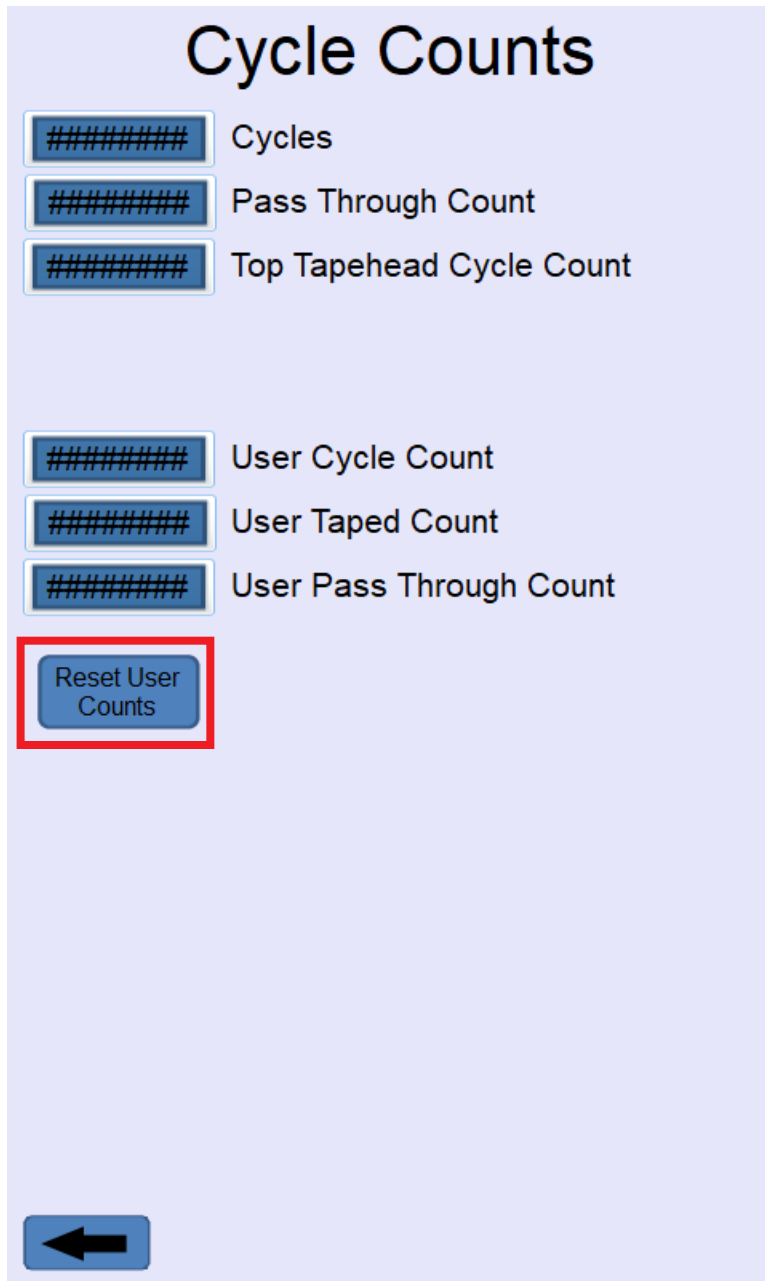
**Figure 60: HMI PLC Output Screen**

This is the PLC Outputs screen and is available to all users. This screen will show all active and inactive outputs on the PLC. Active outputs will have a green box while inactive will be red. This screen is helpful for troubleshooting.

Top only equipment may have a slightly different HMI appearance where items related to the bottom sealing may not be visible.

# HMI WINDOW EXPLANATIONS

## Cycle Counts Screen



<b>CYCLES</b>	Displays the lifetime cycle count of the case sealer.
<b>PASS THROUGH COUNT</b>	Displays the lifetime count of items processed in Pass Through Mode.
<b>TOP TAPEHEAD CYCLE COUNT</b>	Displays the lifetime count of successful top taping.
<b>USER CYCLE COUNT</b>	Displays the cycle count of cases processed since the last user reset.
<b>USER TAPED COUNT</b>	Displays the cycle count of cases that have been successfully taped since the last user reset.
<b>USER PASS THROUGH COUNT</b>	Displays the cycle count of items processed in Pass Through Mode since the last user reset.
<b>RESET USER COUNTS</b>	Pressing this will reset all user cycle counts to 0.
<b>BACK ARROW</b>	Pressing this will return the operator to the Main Menu Screen.

**Figure 61: HMI Cycle Count Screen**

This is the Cycle Counts screen and is available to all users. This screen will show all the cycle count information.

Items highlighted in red are only available through the “Maintenance” level login. Pressing this will reset all the user cycle counts on the screen to 0.

Top only equipment may have a slightly different HMI appearance where items related to the bottom sealing may not be visible.

# HMI WINDOW EXPLANATIONS

## Error Counts Screen

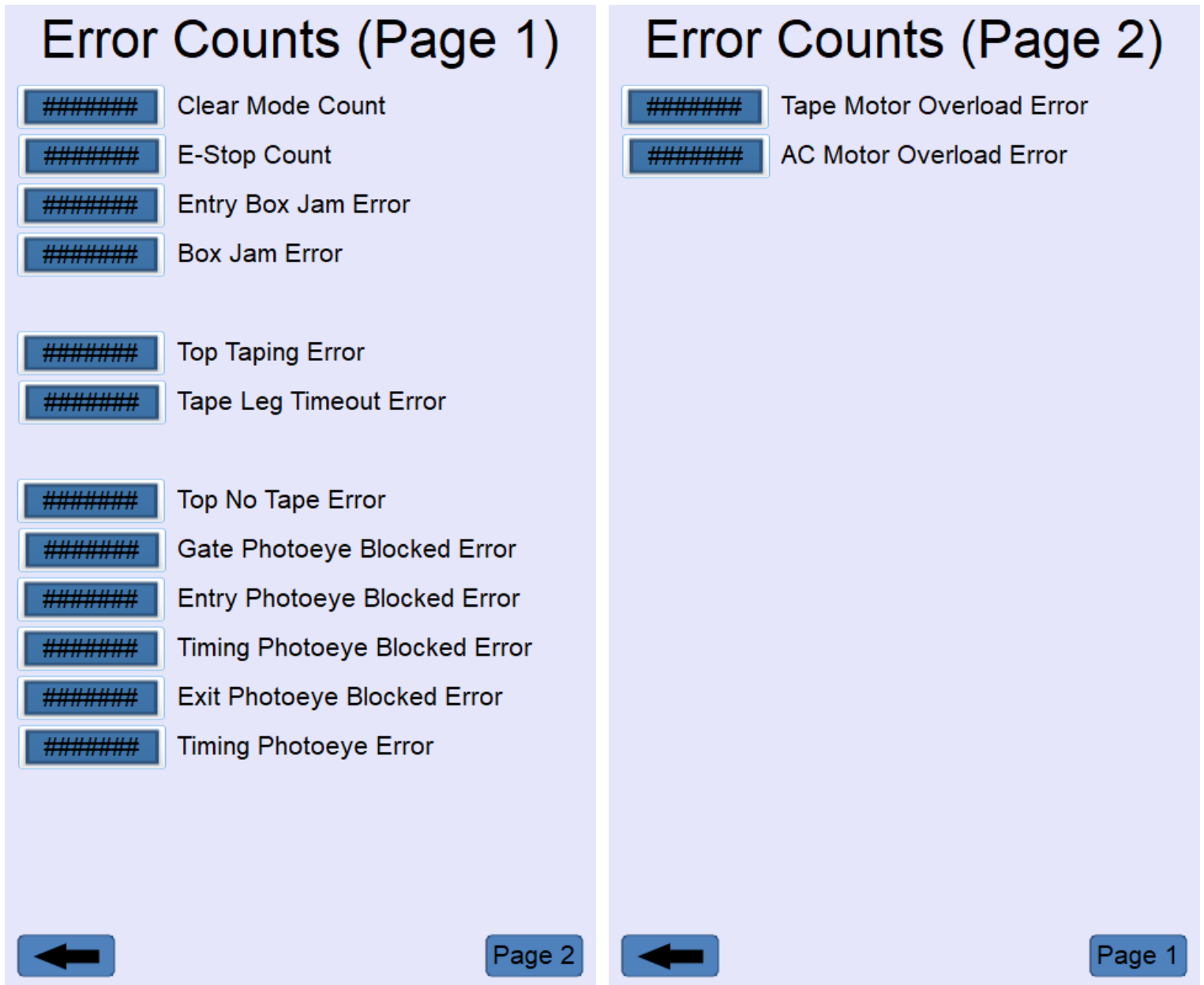


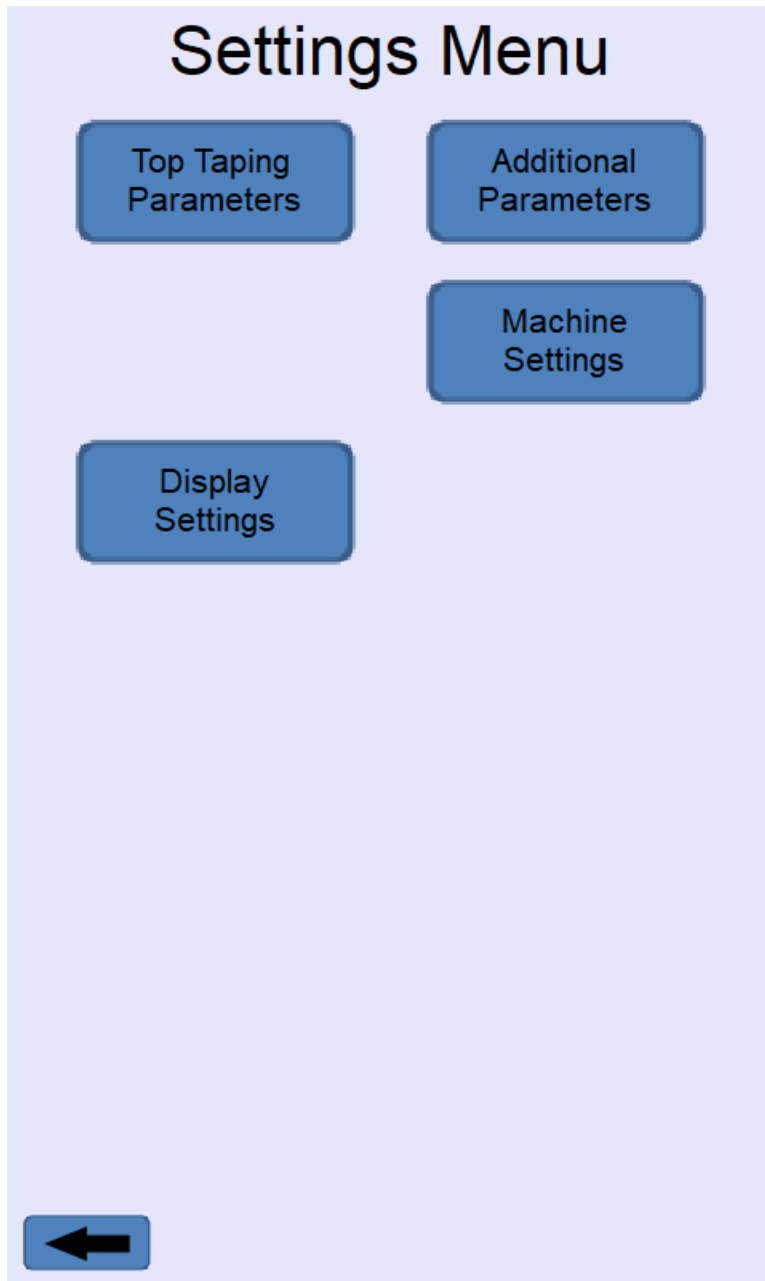
Figure 62: HMI Error Count Screen

This is the Error Counts screen and is available to all users. This screen will show the total error counts that the machine has registered. These screens are helpful for troubleshooting.

Top only equipment may have a slightly different HMI appearance where items related to the bottom sealing may not be visible.

# HMI WINDOW EXPLANATIONS

## Settings Menu Screen



<b>TOP TAPING PARAMETERS</b>	Pressing this will take the operator to the Top Taping Parameters screen.
<b>ADDITIONAL PARAMETERS</b>	Pressing this will take the operator to the Additional Parameters screen.
<b>MACHINE SETTINGS</b>	Pressing this will take the operator to the Machine Settings screen.
<b>DISPLAY SETTINGS</b>	Pressing this will take the operator to the Display Settings screen.
<b>BACK ARROW</b>	Pressing this will return the operator to the Main Menu Screen.

**Figure 63: HMI Settings Menu Screen**

This is the Settings Menu screen and is available to Maintenance and Engineering users. It allows for higher level users to make adjustments to machine settings and parameters.

Top only equipment may have a slightly different HMI appearance where items related to the bottom sealing may not be visible.

# HMI WINDOW EXPLANATIONS

## Top Taping Parameters Screen 1



<b>FRONT TAPE LEG LENGTH</b>	Allows an advanced user to alter the top front tape leg length. Values are in motor pulses.
<b>FRONT TAPE LEG MOTOR SPEED</b>	Allows an advanced user to alter the top front tape leg motor speed. Values are in RPM.
<b>TAPE MOTOR ON POSITION</b>	Allows an advanced user to alter the position of the case when the active taping begins. Values are in inches.
<b>TAPE FEED ASSIST MOTOR SPEED</b>	Used when the pinch roller releases and the box is pulling the tape.
<b>REAR TAPE LEG LENGTH</b>	Allows an advanced user to alter the length of the rear tape leg length. Values are in inches.
<b>TAPE CUT TIMER</b>	Allows an advanced user to alter the length in time that the knife is activated. Values are in seconds.
<b>PINCH ON DELAY</b>	Allows an advanced user to alter the length in time that the pinch roller is deactivated while tape is being cut. Values are in seconds.
<b>ACTIVE SPEED CHANGE</b>	Allows an advanced user to alter the percent of speed change in the active taping procedure. Allows for tape tension adjustment. Values are in percentage of motor speed.
<b>RESET TO DEFAULTS</b>	Pressing this will allow advanced users to reset all top taping values to the set defaults.
<b>PAGE 2</b>	Pressing this will take an advanced user to the second page of parameters.
<b>BACK ARROW</b>	Pressing this will return the operator to the Main Menu Screen.

Figure 64: HMI Tape Parameter Screens

These are the Top Taping Parameters screens and is available to Maintenance and Engineering users. It allows for higher level users to make adjustments to the top taping mechanism. It also contains a “Reset to Defaults” button to restore all the settings to the defaults that are set in the Engineering Menus.

Top only equipment may have a slightly different HMI appearance where items related to the bottom sealing may not be visible.

# HMI WINDOW EXPLANATIONS

## Top Taping Parameters Screen 2



<b>REAR ROLLER ON POSITION FRONT TRIGGER</b>	Allows an advanced user to alter the position of the leading edge of the case when the first rear wipedown roller activates. Values are in inches.
<b>REAR ROLLER ON POSITION REAR TRIGGER</b>	Allows an advanced user to alter the position of the trailing edge of the case when the first rear wipedown roller activates. Values are in inches.
<b>FRONT ROLLER OFF POSITION</b>	Allows an advanced user to alter the position of the trailing edge of the case when the first front wipedown roller retracts. Values are in inches.
<b>ROLLERS HOME POSITION</b>	Allows an advanced user to alter the position of the trailing edge of the case when the first set of rollers return to their home position. Values are in inches.
<b>2ND REAR ROLLER ON POSITION FRONT TRIGGER</b>	Allows an advanced user to alter the position of the leading edge of the case when the second rear wipedown roller activates. Values are in inches.
<b>2ND REAR ROLLER ON POSITION REAR TRIGGER</b>	Allows an advanced user to alter the position of the trailing edge of the case when the second rear wipedown roller activates. Values are in inches.
<b>TAPE LENGTH CALCULATION CORRECTION</b>	Allows an advanced user to enter a correction to calculated tape length. Corrections may be needed for a variety of factors. Values are in inches.
<b>CALIBRATE TAPE MOTOR</b>	Pressing and holding this will allow advanced users to perform a calibration of the taping motor.
<b>RESET TO DEFAULTS</b>	Pressing this will allow advanced users to reset all top taping values to the set defaults.
<b>PAGE 1</b>	Pressing this will take advanced users to page 1 of the settings.
<b>BACK ARROW</b>	Pressing this will return the operator to the Main Menu Screen.

Figure 65: Top Taping Parameters Screen 2

These are the Top Taping Parameters screens and is available to Maintenance and Engineering users. It allows for higher level users to make adjustments to the top taping mechanism. It also contains a “Reset to Defaults” button to restore all the settings to the defaults that are set in the Engineering Menus.

Top only equipment may have a slightly different HMI appearance where items related to the bottom sealing may not be visible.

# HMI WINDOW EXPLANATIONS

## Additional Parameters Screen



<b>ENTRY BOX JAM TIMER</b>	Allows an advanced user to alter the time limit for the case to reach the bottom timing photoeye. Values are in seconds.
<b>BOX JAM TIMER</b>	Allows an advanced user to alter the time limit for the case to finish processing. Values are in seconds.
<b>TAPE LEG TIMEOUT</b>	Allows an advanced user to alter the time between completing the tape leg dispense and when the case sealer will error out. Values are in seconds.
<b>AUTO SHUTOFF TIMER</b>	Allows an advanced user to alter the time between the last case processed and when the case sealer will automatically enter Manual Mode shutting off the belts. Values are in minutes.
<b>OPEN GATE DELAY</b>	Allows an advanced user to alter the time the gate sensor detects the top of the box until the gate opens. Values are in seconds.
<b>CLOSE GATE DELAY</b>	Allows an advanced user to alter the time the gate sensor detects the trailing edge of the box until the gate returns to its home position. Values are in seconds.
<b>TAPING ERROR MARGIN</b>	Allows an advanced user to alter the threshold for a taping error. Values are in inches.
<b>BRIDGE DROP DELAY THRESHOLD</b>	Allows an advanced user to alter the time of the bridge dropping to allow the bottom tape feed to complete. Values are in seconds
<b>BRIDGE DROP DELAY BUMP TIMER</b>	Allows an advanced user to alter the time the bridge will raise when the bottom tape leg has not yet been completed. Values are in seconds
<b>RESET TO DEFAULTS</b>	Allows an advanced user to return all setting in the additional parameters to the set defaults.
<b>PAGE 2</b>	Pressing this will take advanced users to page 2 of the additional parameters.
<b>BACK ARROW</b>	Pressing this will return the operator to the Main Menu Screen.

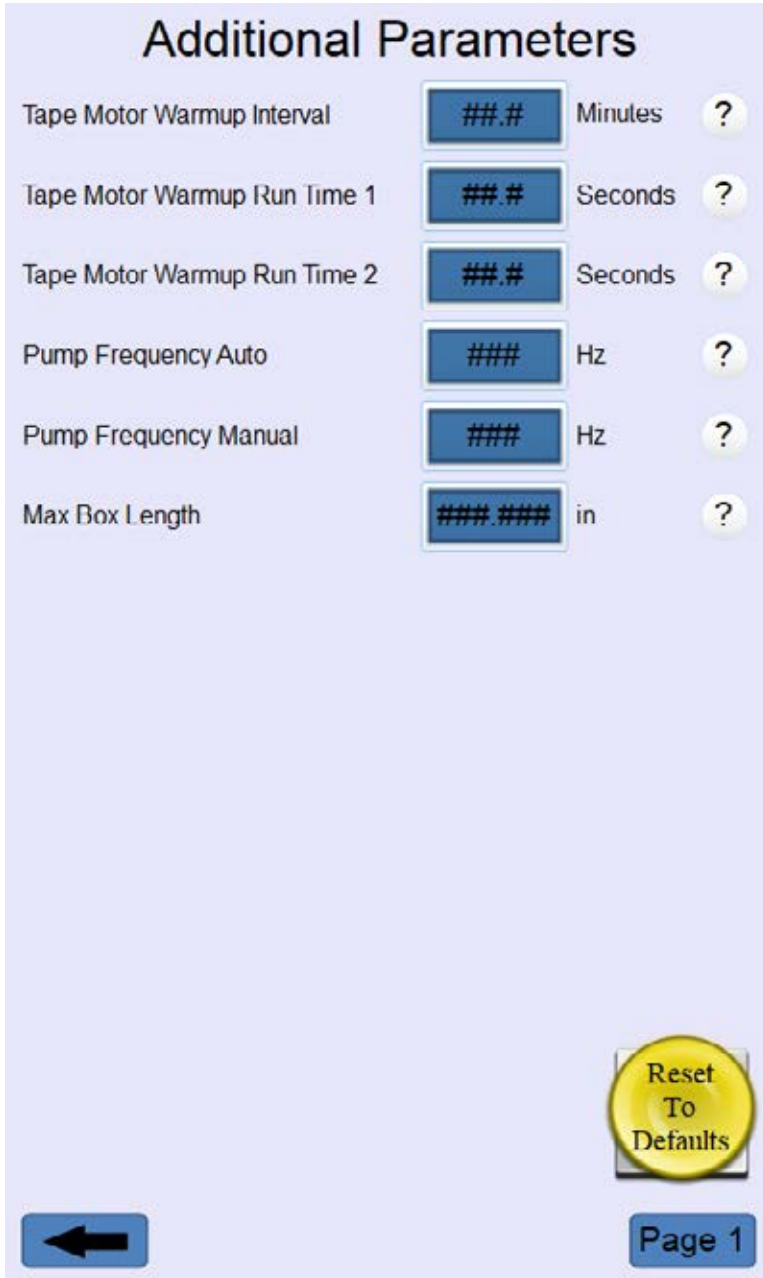
**Figure 66: Additional Parameters Screen 1**

This is the Additional Parameter screen and is available to Maintenance and Engineering users. It allows for higher level users to make adjustments to machine settings and parameters.

Top only equipment may have a slightly different HMI appearance where items related to the bottom sealing may not be visible.

# HMI WINDOW EXPLANATIONS

## Additional Parameters Screen 2



<b>TAPE MOTOR WARMUP INTERVAL</b>	Allows an advanced user to alter the time a tape motor can remain idle. Periodic running keeps speed consistent. Values are in minutes.
<b>TAPE MOTOR WARMUP RUN TIME 1</b>	Allows an advanced user to alter the length of time the tape motors will run after the case sealer boots up. Values are in seconds.
<b>TAPE MOTOR WARMUP RUN TIME 2</b>	Allows an advanced user to alter the length of time the tape motors will run after the Tape Motor Warmup Interval expires. Values are in seconds.
<b>PUMP FREQUENCY AUTO</b>	Allows an advanced user to alter the speed of the water pump when in Auto Mode. Values are in hertz.
<b>PUMP FREQUENCY MANUAL</b>	Allows an advanced user to alter the speed of the water pump when in Manual Mode. Values are in hertz.
<b>MAX BOX LENGTH</b>	Allows an advanced user to set the longest box in the suite. Allows for automatic adjustments for cases over 38" in length. Values are in inches.
<b>RESET TO DEFAULTS</b>	Allows an advanced user to return all setting in the additional parameters to the set defaults.
<b>PAGE 1</b>	Pressing this will take advanced users to page 1 of the Additional Parameters.
<b>BACK ARROW</b>	Pressing this will return the operator to the Main Menu Screen.

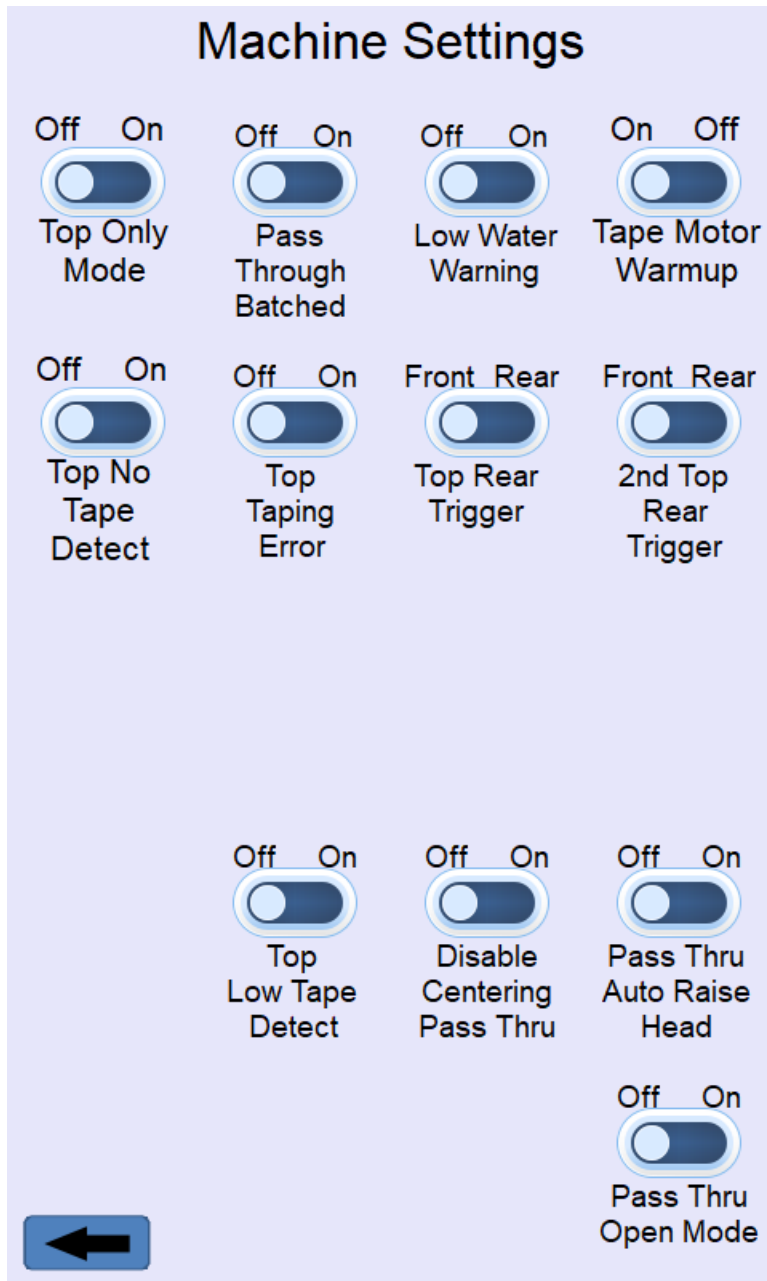
**Figure 67: Additional Parameters Screen 2**

This is the Additional Parameter screen and is available to Maintenance and Engineering users. It allows for higher level users to make adjustments to machine settings and parameters.

Top only equipment may have a slightly different HMI appearance where items related to the bottom sealing may not be visible.

# HMI WINDOW EXPLANATIONS

## Machine Settings Screen



<b>TOP ONLY MODE</b>	Toggles the bottom taping on/off.
<b>PASS THROUGH BATCHED</b>	Toggles Pass Through Batch Mode on/off.
<b>LOW WATER WARNING</b>	Toggles the case sealer reporting if it detects low water. (sold as option)
<b>TAPE MOTOR WARM-UP</b>	Toggles the tape motor warm up routine on/off.
<b>TOP NO TAPE DETECT</b>	Toggles the case sealer reporting if it detects no tape has been applied.
<b>TOP TAPING ERROR</b>	Toggles the case sealer's error reporting and activation of error state after detecting a top tape error.
<b>TOP REAR TRIGGER</b>	Toggles timing of the Rear (or 2nd rear) roller between the front and rear edge of the case
<b>2ND TOP REAR TRIGGER</b>	Toggles timing of the Rear (or 2nd rear) roller between the front and rear edge of the case
<b>TOP LOW TAPE DETECT</b>	Toggles the case sealer reporting it has bottom top tape. (Sold as option)
<b>DISABLE CENTERING PASS THRU</b>	Toggles the centering mechanism on/off when in Pass Through mode.
<b>PASS THRU AUTO RAISE HEAD</b>	Toggles on/off raising the head automatically when entering pass thru mode. Note: The head will drop down onto the top of the box as soon as the box enters.
<b>PASS THRU OPEN MODE</b>	Raises the bridge to the maximum (and keeps it there) while in Pass Thru Mode
<b>BACK ARROW</b>	Pressing this will return the operator to the Main Menu Screen.

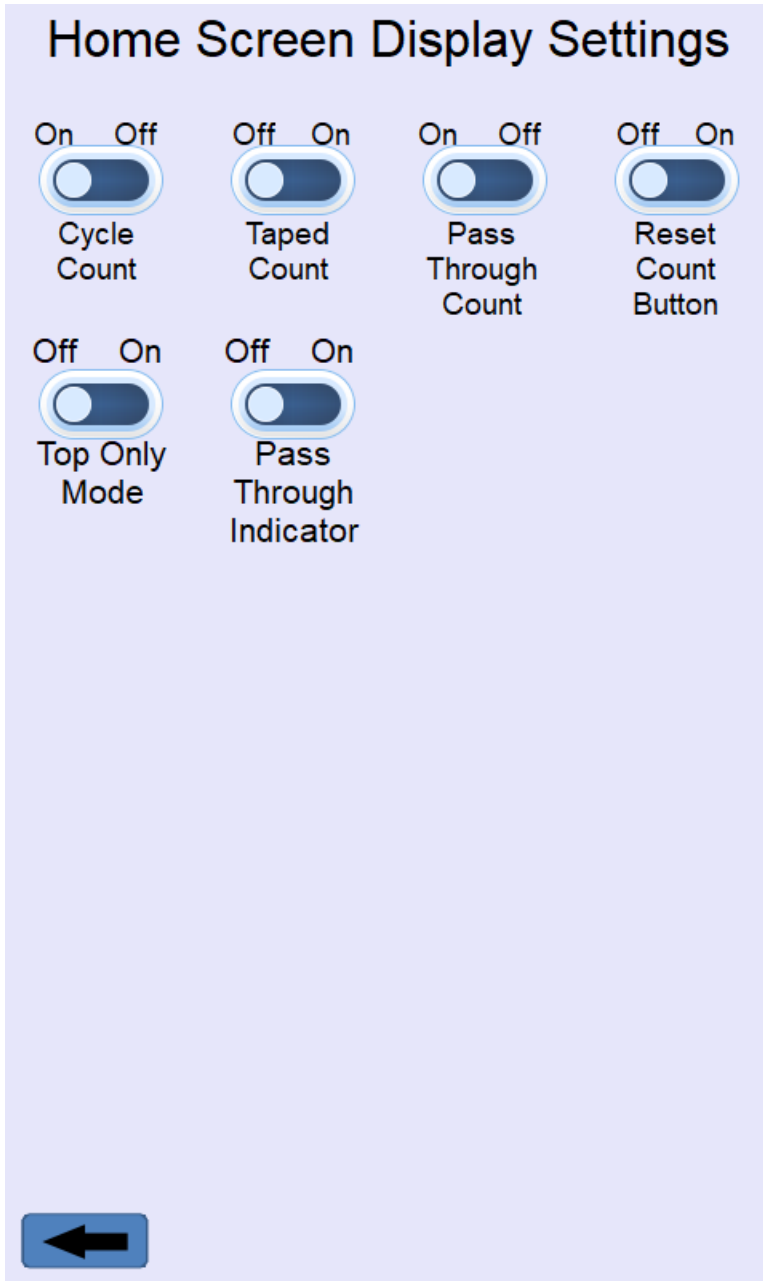
**Figure 68: Machine Settings Screen**

This is the Machine Settings screen and is available to Maintenance and Engineering users. It allows for higher level users to turn on or off various machine features. It also allows the user to change various triggers and timers from the front of a case to the rear of the case.

Top only equipment may have a slightly different HMI appearance where items related to the bottom sealing may not be visible.

# HMI WINDOW EXPLANATIONS

## Home Screen Display Settings Screen



<b>CYCLE COUNT</b>	Toggles the cycle count to be visible on the Home Screen.
<b>TAPED COUNT</b>	Toggles the taped count to be visible on the Home Screen.
<b>PASS THROUGH COUNT</b>	Toggles the pass through count to be visible on the Home Screen.
<b>RESET COUNT BUTTON</b>	Toggles the reset count button to be visible on the Home Screen. This allows any user to reset the counts.
<b>TOP ONLY MODE</b>	Toggles the Top Only selector to be visible on the Home Screen.
<b>PASS THROUGH INDICATOR</b>	Toggles the pass through indicator to be visible on the Home Screen.
<b>BACK ARROW</b>	Pressing this will return the operator to the Main Menu Screen.

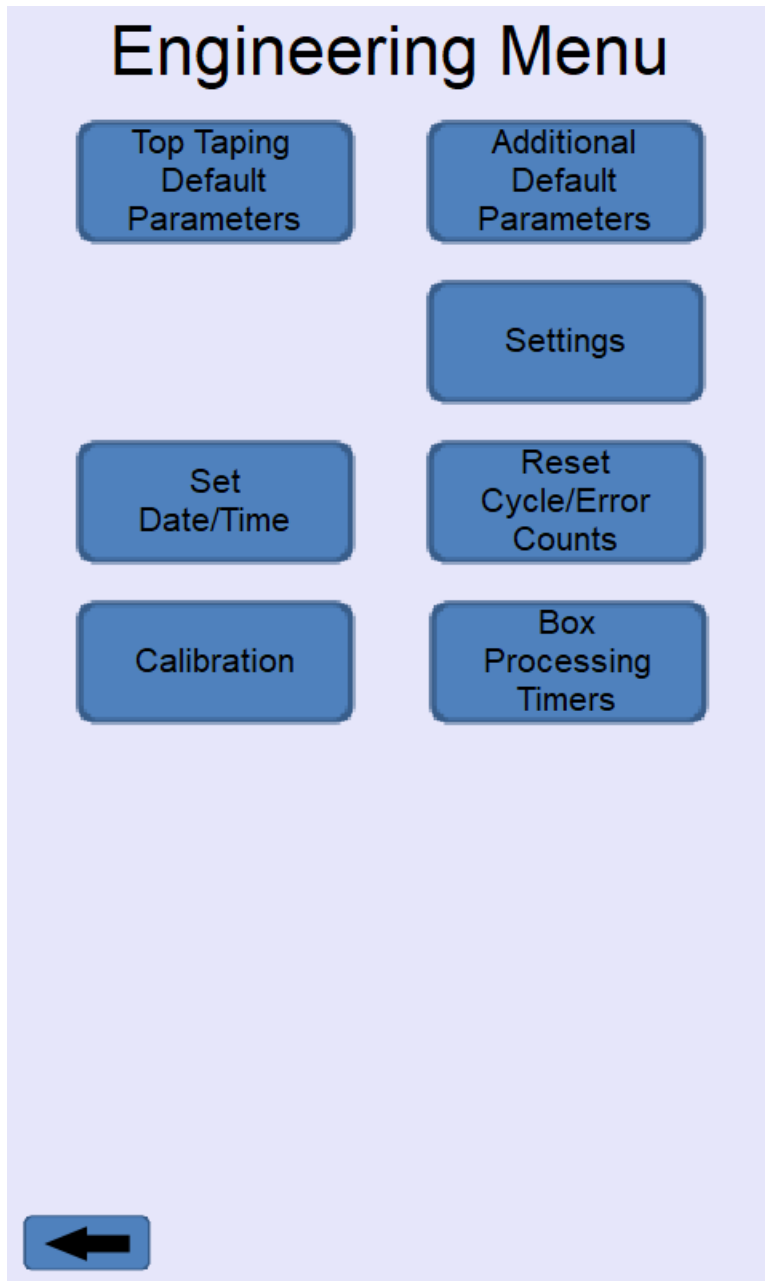
**Figure 69: Home Screen Display Settings Screen**

This is the Home Screen Display Settings screen and is available to Maintenance and Engineering users. It allows for higher level users to turn on or off the visual indicators that are outlined in the “Home Screen Page.”

Top only equipment may have a slightly different HMI appearance where items related to the bottom sealing may not be visible.

# HMI WINDOW EXPLANATIONS

## Engineering Menu Screen



<b>TOP TAPING DEFAULT PARAMETERS</b>	Pressing this takes an engineering user to the Top Taping Default Parameters Screen.
<b>ADDITIONAL DEFAULT PARAMETERS</b>	Pressing this takes an engineering user to the Additional Default Parameters Screen.
<b>SETTINGS</b>	Pressing this takes an engineering user to the Settings Screen.
<b>SET DATE/TIME</b>	Pressing this takes an engineering user to the Set Date/Time Screen.
<b>RESET CYCLE/ ERROR COUNTS</b>	Pressing this takes an engineering user to the Reset Cycle/Error Count Screen.
<b>CALIBRATION</b>	Pressing this takes an engineering user to the Calibration Screen.
<b>BOX PROCESSING TIMERS</b>	Pressing this takes an engineering user to the Box Processing Timers Screen.
<b>BACK ARROW</b>	Pressing this will return the operator to the Main Menu Screen.

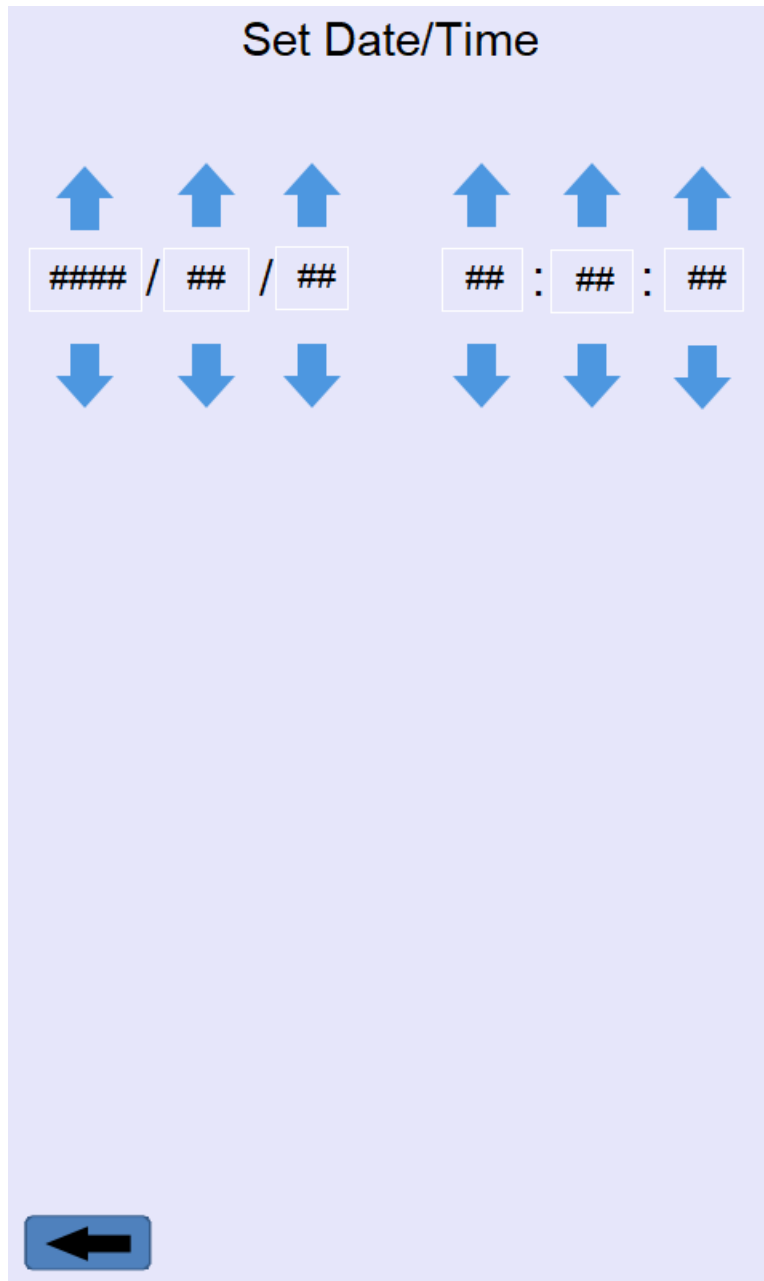
**Figure 70: Engineering Menu Screen**

This is the Engineering Menu screen and is available to Engineering users. It allows for higher level users to access the various advanced machine settings. Only authorized personnel should access and make changes to items contained within this menu.

Top only equipment may have a slightly different HMI appearance where items related to the bottom sealing may not be visible.

# HMI WINDOW EXPLANATIONS

## Set Date/Time Screen

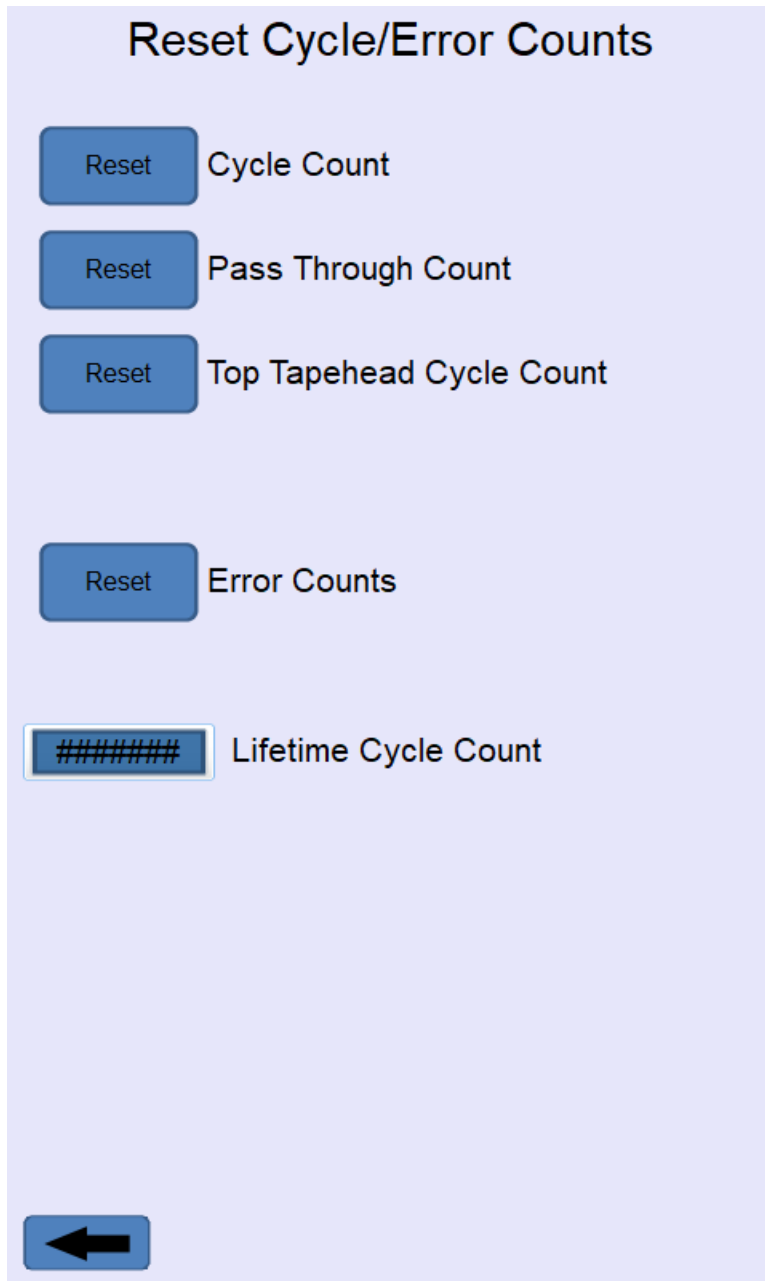


**Figure 71: Set Date/Time Screen**

This is the Set Date/Time screen and is available to Engineering users. It allows for higher level users to change the date and time. This should be set up at the time of install and correspond to the local time zone.

# HMI WINDOW EXPLANATIONS

## Reset Cycle/Error Counts Screen



<b>RESET CYCLE COUNT</b>	Pressing this allows an engineering user to reset the case sealer's cycle count.
<b>RESET PASS THROUGH COUNT</b>	Pressing this allows an engineering user to reset the case sealer's pass through count.
<b>RESET TOP TAPEHEAD CYCLE COUNT</b>	Pressing this allows an engineering user to reset the case sealer's top tapehead cycle count.
<b>RESET ERROR COUNTS</b>	Pressing this allows an engineering user to reset the case sealer's error count.
<b>LIFETIME CYCLE COUNT</b>	Displays the case sealer's lifetime cycle count. This can only be reset by reprogramming the case sealer.
<b>BACK ARROW</b>	Pressing this will return the operator to the Main Menu Screen.

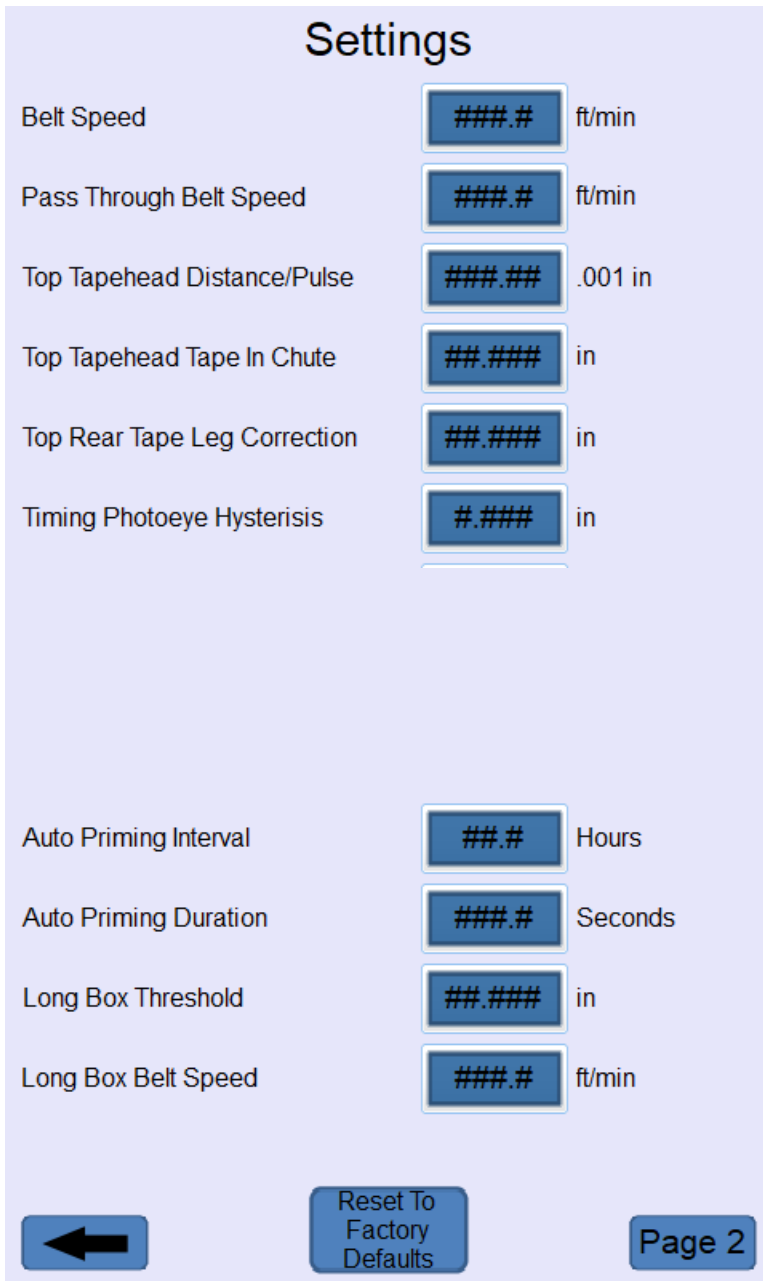
**Figure 72: Reset Cycle/Error Counts Screen**

This is the Reset Cycle/Error Counts screen and is available to Engineering users. It allows for higher level users to reset the various counts to zero (0). The "Lifetime Cycle Count" cannot be reset.

Top only equipment may have a slightly different HMI appearance where items related to the bottom sealing may not be visible.

# HMI WINDOW EXPLANATIONS

## Engineering Settings Screen



<b>BELT SPEED</b>	Allows an engineering user to set the belt speed.
<b>PASS THROUGH BELT SPEED</b>	Allows an engineering user to set the pass through belt speed.
<b>TOP TAPE HEAD DISTANCE/PULSE</b>	Allows an engineering user to set the distance tape travels per motor pulse.
<b>TOP TAPEHEAD TAPE IN CHUTE</b>	Allows an engineering user to set the amount of tape in the chute.
<b>TOP REAR TAPE LEG CORRECTION</b>	Allows an engineering user to set an adjustment to correct inconsistencies in the rear tape leg.
<b>TIMING PHOTOEYE HYSTERISIS</b>	Allows an engineering user to set the adjustment in the hysteresis of the timing photoeye.
<b>AUTO PRIMING INTERVAL</b>	Allows an engineering user to set the interval between turning on the water pump.
<b>AUTO PRIMING DURATION</b>	Allows an engineering user to set the length of time the water pump will run for.
<b>LONG BOX THRESHOLD</b>	Allows an engineering user to set the length of box to slow the belts down.
<b>LONG BOX BELT SPEED</b>	Allows an engineering user to set the speed the case sealer will go to when it detects a box that crosses the Long Box Threshold.
<b>BACK ARROW</b>	Pressing this will return the operator to the Main Menu Screen.

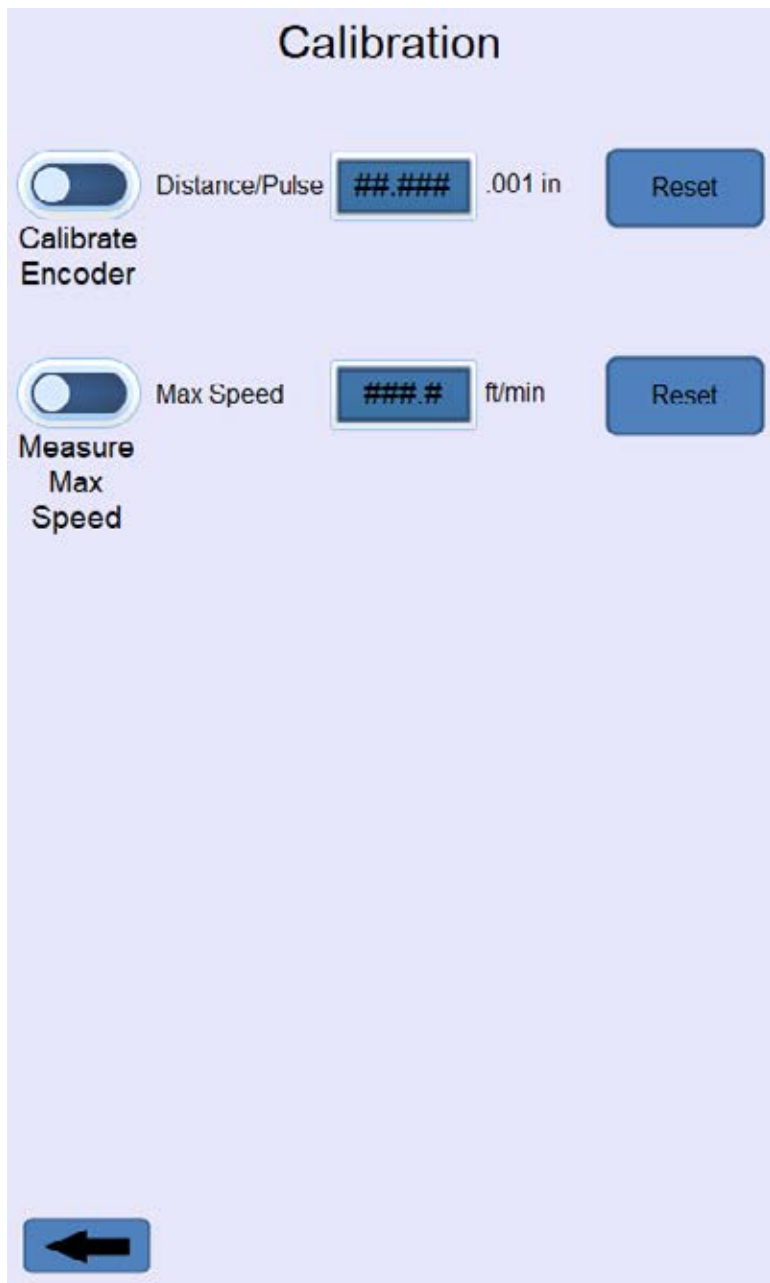
**Figure 73: Engineering Settings Screen**

This is the Settings screen and is available to Engineering users. It allows for higher level users to change advanced functional settings. Elements on this screen should only be altered by Authorized IPG Personnel. Altering these settings can result in the case sealer not functioning as expected.

Top only equipment may have a slightly different HMI appearance where items related to the bottom sealing may not be visible.

# HMI WINDOW EXPLANATIONS

## Calibration Screen



<b>CALIBRATE ENCODER</b>	Allows an engineering user to calibrate the belt encoder.
<b>RESET ENCODER CALIBRATION</b>	Allows an engineering user to reset the encoder calibration to factory default.
<b>MEASURE MAX SPEED</b>	Allows an engineering user to measure the max speed of the tape motors.
<b>RESET MEASURED MAX SPEED</b>	Allows an engineering user to reset the max speed to factory default.
<b>BACK ARROW</b>	Pressing this will return the operator to the Main Menu Screen.

**Figure 74: Calibration Screen**

This is the Calibration screen and is available to Engineering users. It allows for higher level users to calibrate the sync speeds between the drive belts and tape dispensing speeds.

Top only equipment may have a slightly different HMI appearance where items related to the bottom sealing may not be visible.

# HMI WINDOW EXPLANATIONS

## Measurements & Calculations Screen



<b>BOX LENGTH</b>	Displays the calculated box length (calculated using the photoeyes).
<b>TOP TAPE LENGTH CALCULATED</b>	Displays the calculated length of the top tape.
<b>TOP TAPE LENGTH DISPENSED</b>	Displays the dispensed length of top tape via the encoder.
<b>TOP CUT POSITION</b>	Displays the top tape cut position.
<b>BOX FRONT EXIT POSITION</b>	Displays the exit position of the front edge of the case.
<b>MAX TOP TAPE MOTOR SPEED</b>	Displays the maximum speed of the top tape motor speed.
<b>BELT SPEED</b>	Displays the belt speed.
<b>BACK ARROW</b>	Pressing this will return the operator to the Main Menu Screen.

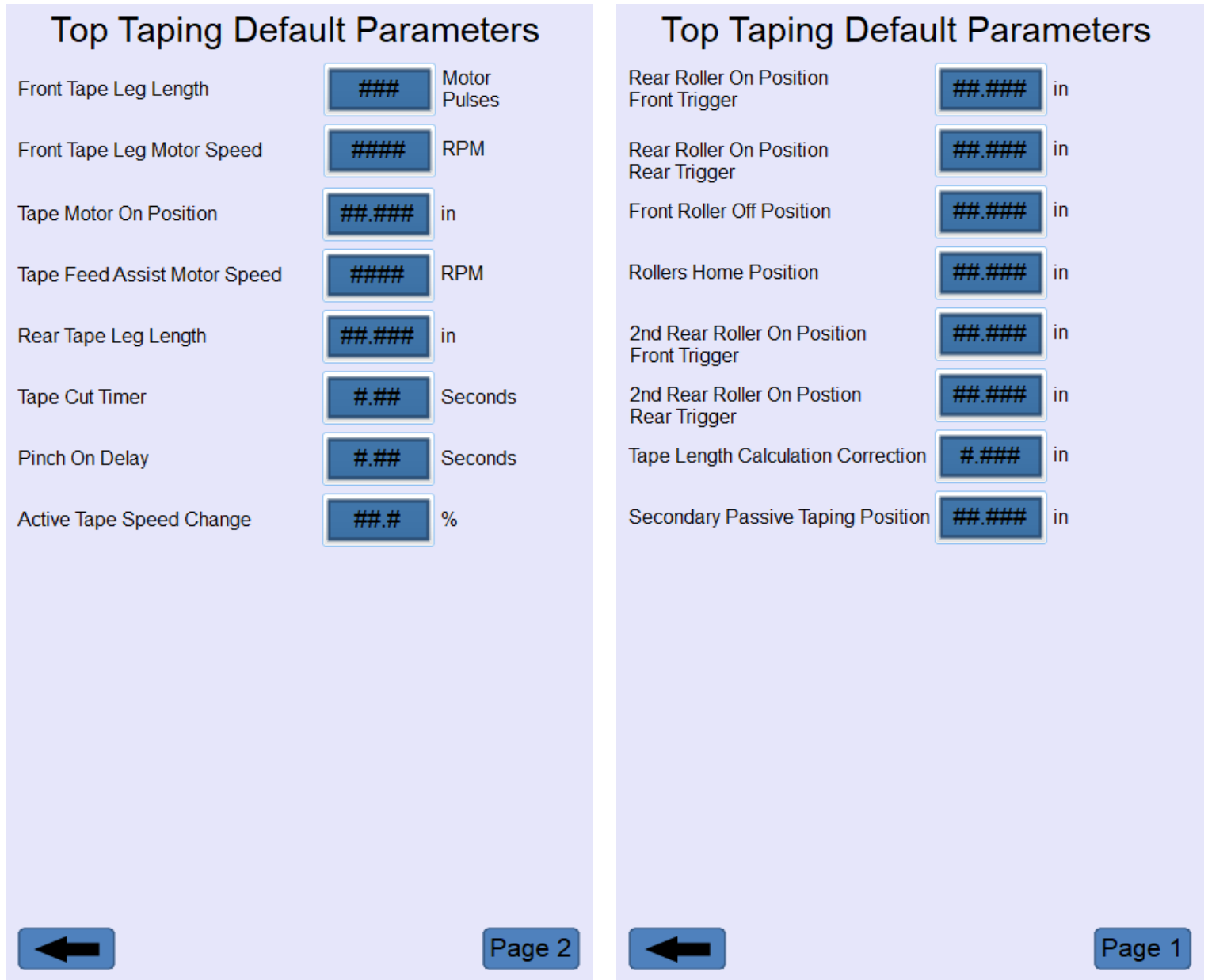
**Figure 75: Measurements & Calibrations Screen**

This is the Measurements & Calculations screen and is available to Engineering users. It allows for higher level users to monitor various calculated values in the case processing routine.

Top only equipment may have a slightly different HMI appearance where items related to the bottom sealing may not be visible.

# HMI WINDOW EXPLANATIONS

## Taping Default Parameters Screens



**Figure 76: Taping Default Parameters Screens**

These are the Taping Default Parameters screens and are available to Engineering users. It allows for higher level users to set system defaults for timers and settings for the top and bottom taping mechanisms. These will become the values that will populate the taping parameter screens when the user presses the “Reset to Default” button.

Top only equipment may have a slightly different HMI appearance where items related to the bottom sealing may not be visible.

# HMI WINDOW EXPLANATIONS

## Additional Default Parameters Screens

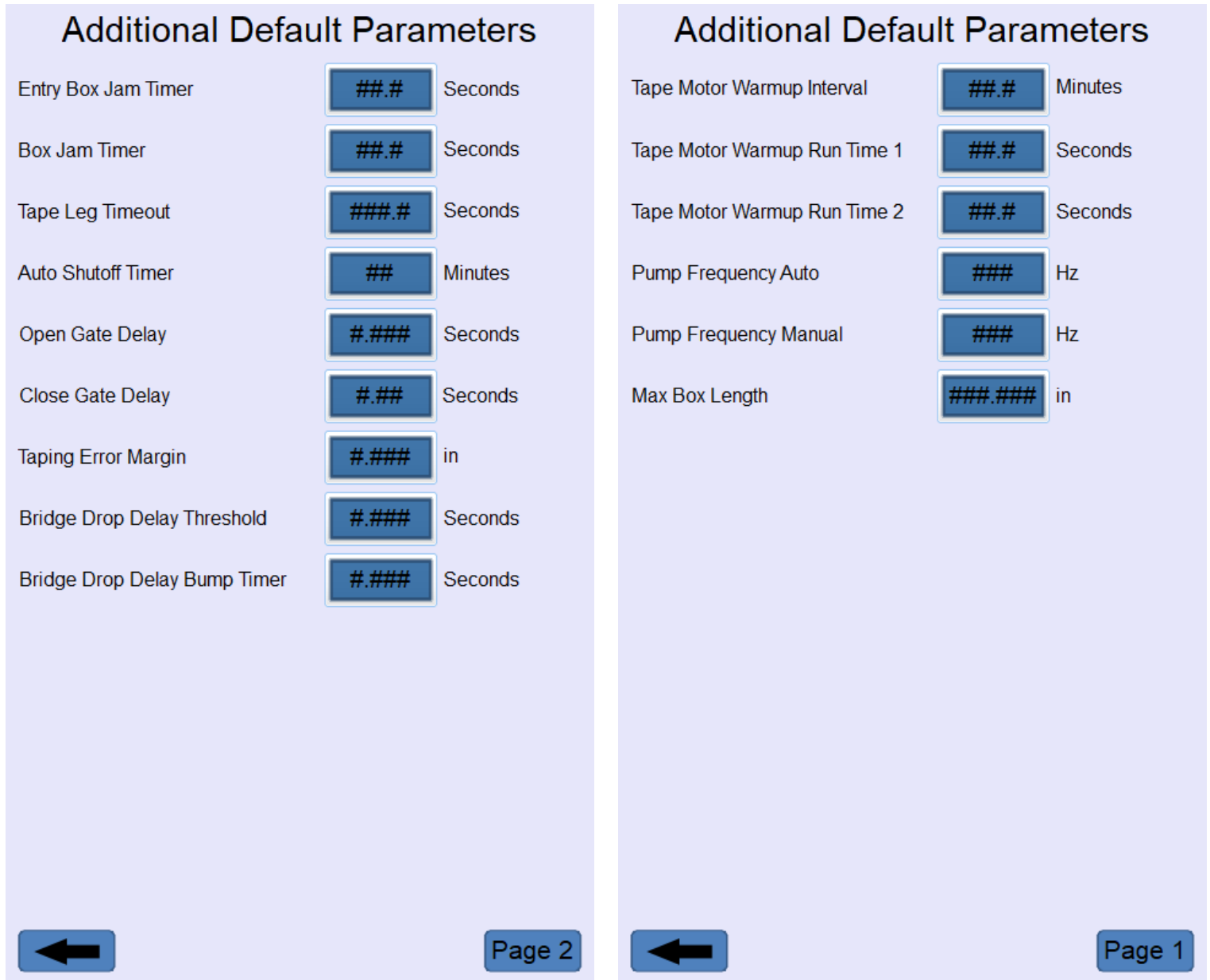


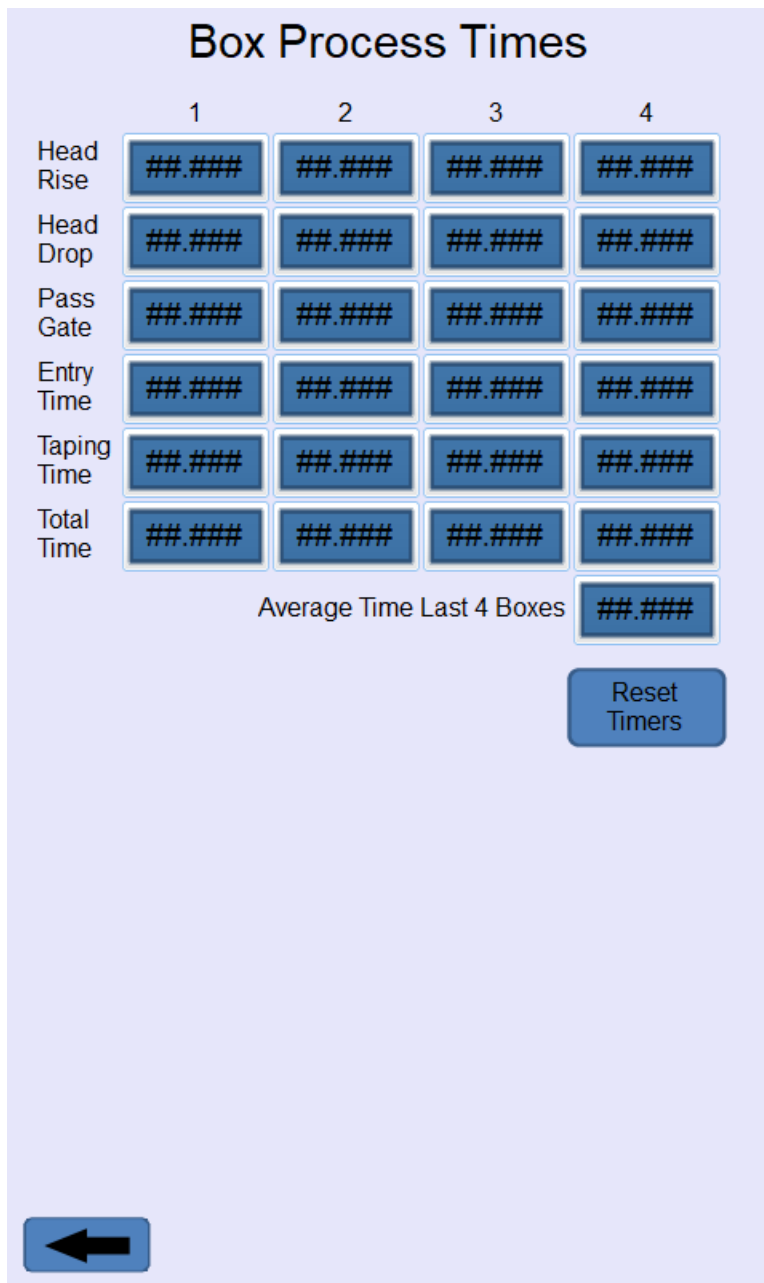
Figure 77: Additional Default Parameters Screens

These are the Additional Default Parameters screens and are available to Engineering users. It allows for higher level users to set system defaults for timers and settings that are unrelated to the dispensing and application of tape on a carton. These will become the values that will populate the Additional Parameter screens when the user presses the "Reset to Default" button.

Top only equipment may have a slightly different HMI appearance where items related to the bottom sealing may not be visible.

# HMI WINDOW EXPLANATIONS

## Pox Process Times Screen



**Figure 78: Box Processing Times Screen**

This is the Box Process Times screen and is available to Engineering users. It allows for higher level users to monitor how much time each of the notated processing elements takes along with a total. The case sealer will remember the last four (4) cartons that were processed and will average that time and display it.

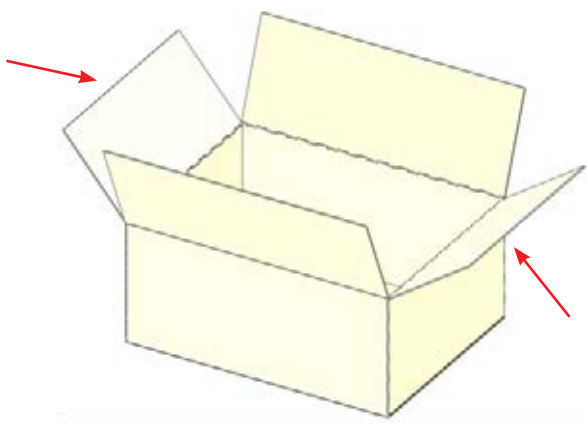
Top only equipment may have a slightly different HMI appearance where items related to the bottom sealing may not be visible.

# PREPARING CASES TO BE PROCESSED CONTINUED

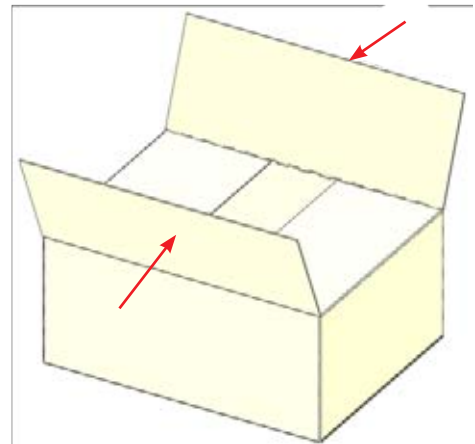
## Flap Folding

The **RSA 2626-WAT-TB Top Only** is a top and bottom belt sealer that will apply a single strip of IPG brand water activated tape to the center seams of a regular slotted carton (RSC). Cartons processed through the **RSA 2626-WAT-TB Top Only** will need to have all of the flaps closed for proper processing. If flaps are not closed there is a high likelihood that there will be a case jam or tape application error.

1. Fold minor flaps inward as shown in Figure 88
2. Fold major flaps inward, as shown in Figure 89



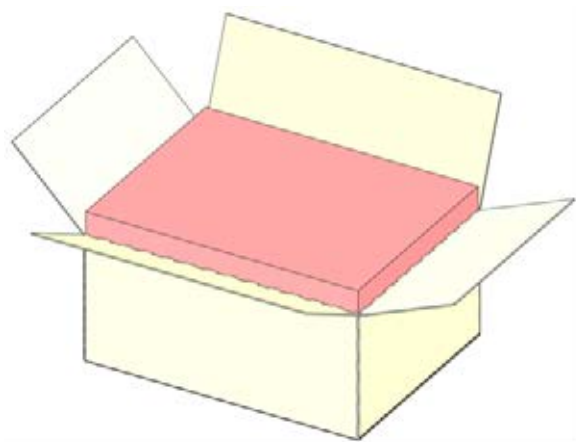
**Figure 79: Folding Minor Flaps**



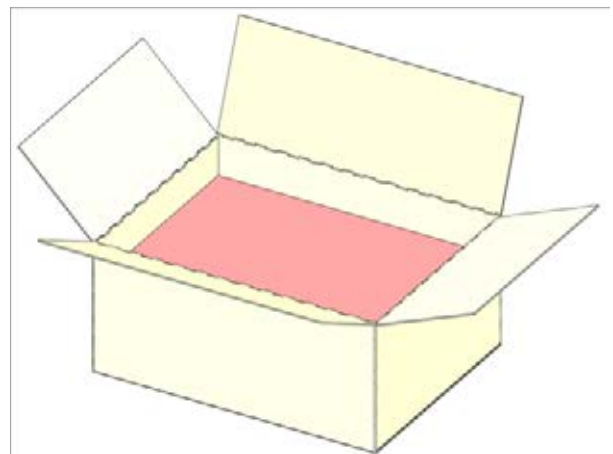
**Figure 80: Folding Major Flaps**

## Over Filled and Void Filled Cartons

Care should be taken when processing over filled and void filled cartons. Both pose different challenges that may require some adjustments to the case sealer and/or tape heads.



**Figure 81: Over Fill**

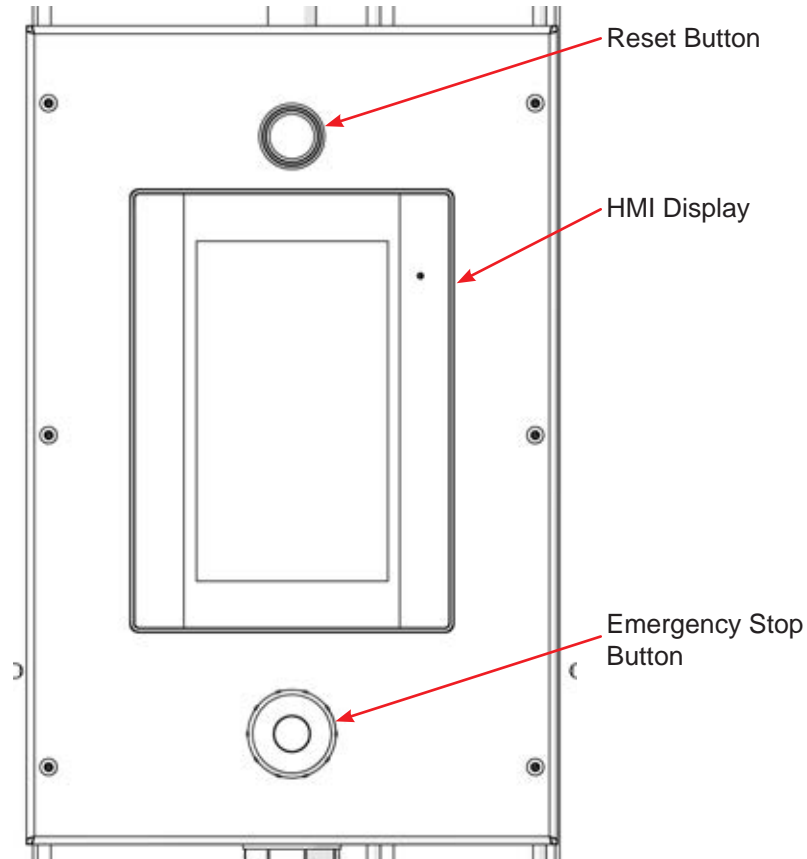


**Figure 82: Under Fill**

# OPERATION MODES

## Control Box

The **RSA 2626-WAT-TB Top Only** Case Sealer has three operating modes: Auto, Manual, and Pass Through. The operator selects these modes, using various methods as described below.



**Figure 83: Operator Controls**

## Manual Mode

This mode is used for troubleshooting and loading tape on to machine. Manual Mode is entered anytime the “Pause” button on the HMI has been pressed. This will stop the belts and if a case was being processed it will stop the sealing procedure. Manual Mode can also be entered by navigating to the Manual screen on the HMI. Navigating to this screen will act in the same way as pressing the “Pause” button.

In Manual Mode an operator can actuate any of the machine’s pneumatic and/or electric movements through selectable options on the Manual Screen of the HMI. For a list of all the functions on the Manual Screen please see the HMI Window Explanations section of this manual.

# OPERATION MODES

---

## Auto Mode

This is the standard operating mode of the machine. In this mode, the belt motors will be active. The home position of the bridge is in the lowest possible position it can go, this may be adjustable. When a case is presented to the machine centering guides will automatically center the case. When the case is pressed against the front paddle of the bridge it will rise automatically. Pushing the case into the machine the bridge will lower on the case and pull it through the machine to process, applying a single strip of IPG brand water activated tape to the top and/or bottom center seam.

1. Ensure that the compressed air is plugged and pressure regulator set to 90 PSI.
2. Press the Reset button if it is blinking.
3. On the HMI, press the Start button, the drive belts will turn on.
4. Introduce a case to the infeed of the case sealer. Grasping the case from the top rear. Do not place hands in front of case or on the sides.
5. Push the case into the case sealer.
6. The case sealer will then take and process the case.

When the case sealer is processing a case the front paddle of the bridge will not respond until the case sealer has finished applying tape to the case currently in the machine. An operator may have a case waiting on the centering table while the case sealer is applying tape to a different case.

The case sealer has the ability to detect most tape application errors and case jams. In the event of one of these errors the belts will stop moving and the error will display on the HMI.

## **Proper Jam Clearing**

In the event of a case jam the case sealer will stop automatically. The operator should follow the below steps to ensure safety and prevent any damage to the equipment or product.

1. After the case sealer stops the operator should read the error message on the HMI.
2. The operator should press the "Clear" button on the HMI.
  - This action will cause the case sealer's bridge to raise up all the way and cut any tape that has been dispensed. When these actions are completed the case sealer will dump the air from the system discharging any stored pneumatic energy.
3. The operator can now open the appropriate door of the case sealer that allows for the safest removal of the carton.
  - This action will interrupt the safety circuit and act identically as an emergency-stop press. This will stop the flow of power to many systems and place the case sealer in a low energy state. Some elements inside the electrical cabinet will remain powered including the PLC and HMI.
4. The operator should remove the jammed carton and any dispensed tape from the machines.
5. The operator should follow any plant procedures and policies on how to inspect and reprocess the material that was inside the jammed case.
6. The operator can now close any doors that were opened and disengage any emergency-stop buttons that may have been pressed.
7. Pressing the blue "Reset" button on the operator control box will return air pressure and power to all elements of the case sealer. The case sealer will now be in a state that is ready to use.
8. The operator should then navigate to the "Manual Screen" on the HMI.
9. Pressing the "Tape Feed" button will dispense a small amount of tape from the top and/or bottom mechanisms. This will ensure the tape path is clear and prime the mechanisms for the new carton.
10. The operator will need to remove the dispensed tape before processing any new cases.
11. If the operator opens any doors in the process they will need to press the blue "Reset" button again before continuing.
12. To return to normal operation the operator will press the "Start" button on the HMI. This will cause the bridge to return to its home position.
13. The case sealer is now ready to accept a new case for processing.

# OPERATION MODES

---

## Pass Through Mode

This mode will allow for material to process through the case sealer without being taped. There are several variations on Pass Through Mode that are selectable through the settings in the HMI. These may be adjusted at any time by a supervisor with access to the case sealer's setting.

There are two primary methods of setting up Pass Through Mode: Batch and Single.

### **Pass Through Batch Mode**

When the Batch Mode is turned on in the case sealer's settings, the operator will enter Pass Through Mode by a single press of the supplied foot switch. This will speed up the motors and allow for items to be sent through the case sealer without tape being applied. The case sealer will remain in Pass Through Mode processing every item presented to it without applying tape until the operator presses the foot switch for a second time. On the second press the case sealer will return to Auto Mode and apply tape to the cases presented to it.

### **Pass Through Single Mode**

When Batch Mode is turned off in the case sealer's settings, the operator will enter Pass Through Mode by a single press of the supplied foot switch. This will speed up the motors and allow for a single item to be sent through the case sealer without tape being applied. Once the item has exited the case sealer it will return to Auto Mode and apply to the cases presented to it.

If an operator holds down the foot switch while in Pass Through Single Mode the case sealer will not apply tape to any item presented to it. The operator will need to release the foot switch to return to Auto Mode.

There are two primary actions the case sealer can take when entering Pass Through Mode: Open and Closed.

### **Open**

When the Open option is selected in the Pass Through Settings the case sealer will, when entering Pass Through Mode, raise the bridge to its maximum position. This allows for unusually shaped items such as totes, mailers, or bags to be sent down the same line as unsealer cases. This allows for a more streamlined shipping process for anyone who may need to send various types of shipments.

### **Close**

When the Open option is turned off in the Pass Through Settings the case sealer's bridge will, when entering Pass Through Mode, function as normal. Raising when an item is presented to the front paddle and resting on the top of that item so that both the top and bottom belts drive the item though the case sealer without applying tape to that item. This allows for SIOC (Ship in Own Container) boxes to be sent down the same line as unsealer cases. It is not recommended to use Close mode if any item other than cases is sent through Pass Through Mode.

### **Centering Mechanism**

The centering guides may also be turned off when the case sealer enters Pass Through Mode. This is done through the cases sealer's settings on the HMI. When this option is turned on the centering guides will not activate when the first photo-eye is covered. It is recommended to turn the centering guides off if any non-case items will be processed through Pass Through Mode, such as mailers or bags.

The centering guides can be turned off in any operational mode of Pass Through. If they are off and Open Mode is turned off the operator should present any items as centered as possible to the case sealer's belts. This will ensure even pressure is applied to the top of the item.

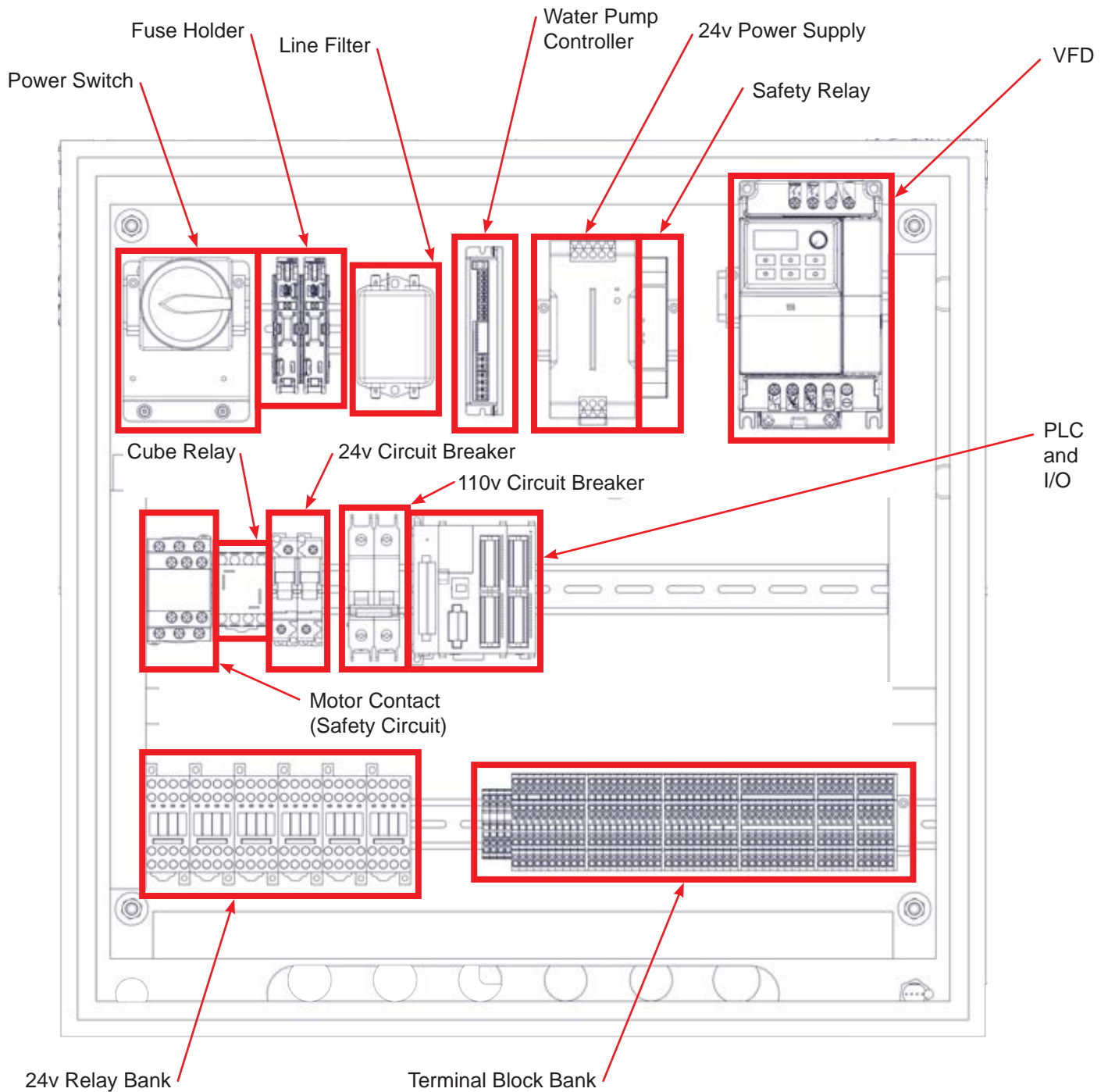
# TROUBLESHOOTING

The **RSA 2626-WAT-TB Top Only** Case Sealer is fabricated with high quality components that provide trouble-free operation for a long period of time. However, should a problem occur, we recommend that you consult the following pages. If the problem you encounter is not discussed in these pages, call IPG Machinery Support at 813-345-3070.

## Electrical Enclosure



**WARNING: ONLY QUALIFIED SERVICE PERSONNEL SHOULD OPEN THE ELECTRICAL CABINET. UNDER NO CIRCUMSTANCE SHOULD AN OPERATOR ATTEMPT TO OPEN THE ELECTRICAL CABINET.**



**Figure 84: Electrical Enclosure**

# TROUBLESHOOTING

---

## Q & A

The following is a short set of brief questions and answers for some mild troubleshooting in WAT case sealers. More in-depth troubleshooting can be found in this section.

### **Q: How long is the tape good for once it gets wet?**

It is recommended to process a case within 45 seconds of the initial tape leg being dispensed. Any longer the adhesive will begin to dry and will not stick to the case. Case sealers running the newest software package will have a time out system that will automatically cut the tape and turn off the belts in the event this happens.

### **Q: Are the top and bottom tape heads interchangeable?**

IPG Water Activated Tape Heads are manufactured in a top or bottom configuration and are not interchangeable. Those in the RSA 2626-TB WAT are not interchangeable with any other IPG equipment.

IPG manufactures a 24v version of the WAT heads for adaptation into other equipment. Do not attempt to install a 24v tape head into a machine that is not wired correctly for it.



**CAUTION: BE SURE TO NOT INSTALL 24V TAPE HEADS INTO EQUIPMENT THEY ARE NOT RATED FOR. THIS WILL CAUSE DAMAGE TO THE TAPE HEAD AND MAY RESULT IN INJURY.**

The RSA 2626-TB WAT uses specialty tape application mechanisms in place of the traditional tape heads found in other WAT case sealers manufactured by IPG.

### **Q: Can pressure sensitive tape heads replace WAT ones?**

Due to manufacturing differences there is not a way to drop in replace the WAT heads with pressure sensitive counterparts.

### **Q: What is the best way to clean the tape heads?**

It is recommended to clean the tape path with a mild detergent and water solution. Do not use any harsh industrial cleaners as they can deteriorate parts quickly. Do not use excessive amounts of water and dry the tape head soon after washing. Be sure the tape path is dry before reinstalling the tape head or rethreading tape.

### **Q: Can we reverse the side the tape is loaded on?**

On WAT case sealers it is a special order to reverse the top tape mandrel to allow for it to be loaded from the reverse side.

### **Q: Can I use a mobile compressor to operate the case sealer?**

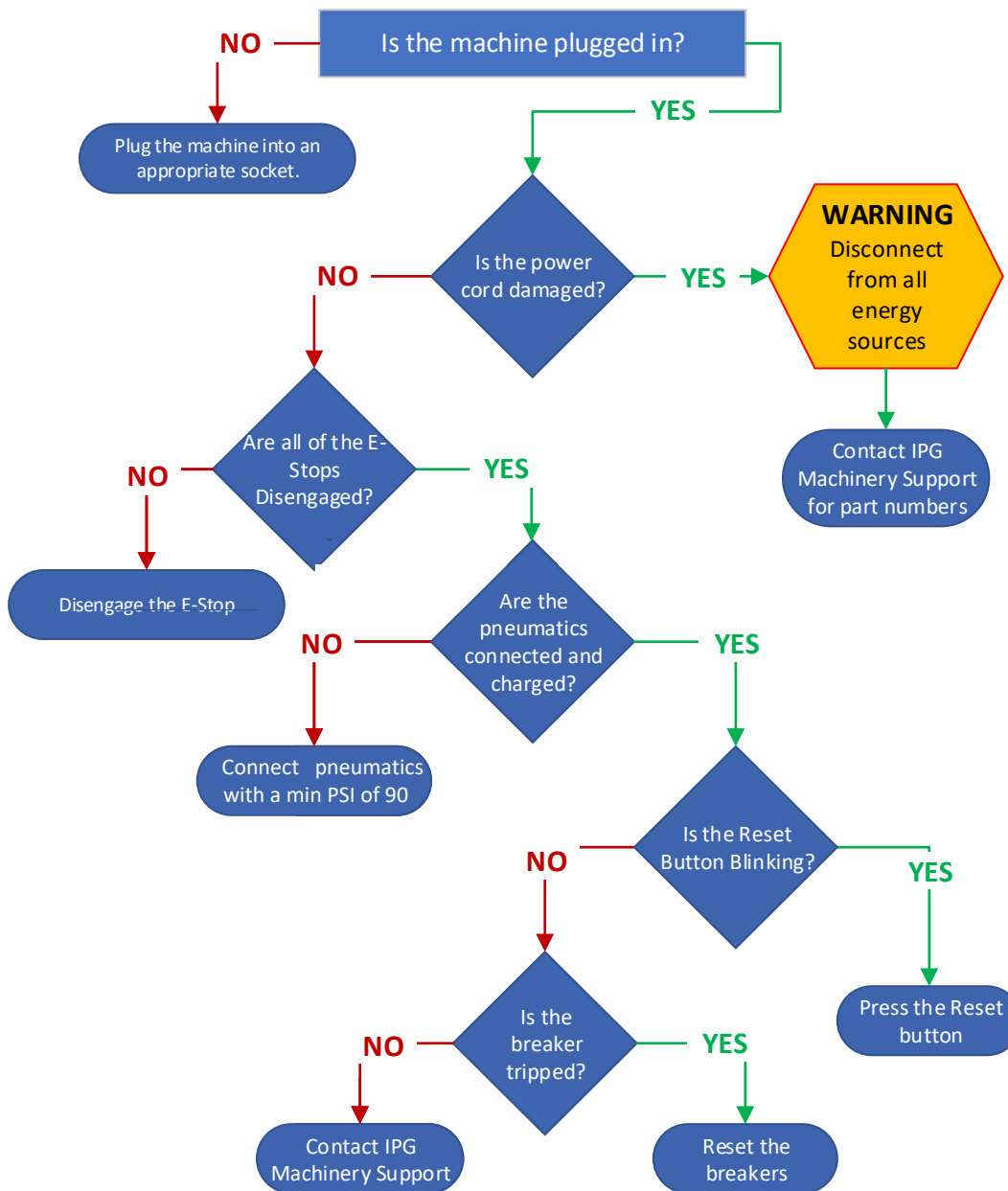
It is recommended to use a large compressor capable of producing a sustained 9 CFM at 90 PSI. If a compressor is used that is below this level it is possible to have unintended action, poor taping, or even a lack of pneumatic movement entirely. Smaller compressors are also more likely to introduce moisture into the air lines which can cause a degradation of internal components on the case sealer and tape head(s). Use only clean dry air with IPG manufactured equipment.

### **Q: Can I change machine settings?**

While IPG WAT Case Sealers can have their settings adjusted through a password protected portion of the HMI screen it is recommended to contact IPG Machine Support prior to making any changes. The machine should have been set up by an Authorized IPG Representative and any tweaks that would need to have been made on site for your specific box suite would have been saved. Making changes to the settings could result in poor tape application, unintended movement, or potentially damage the equipment.

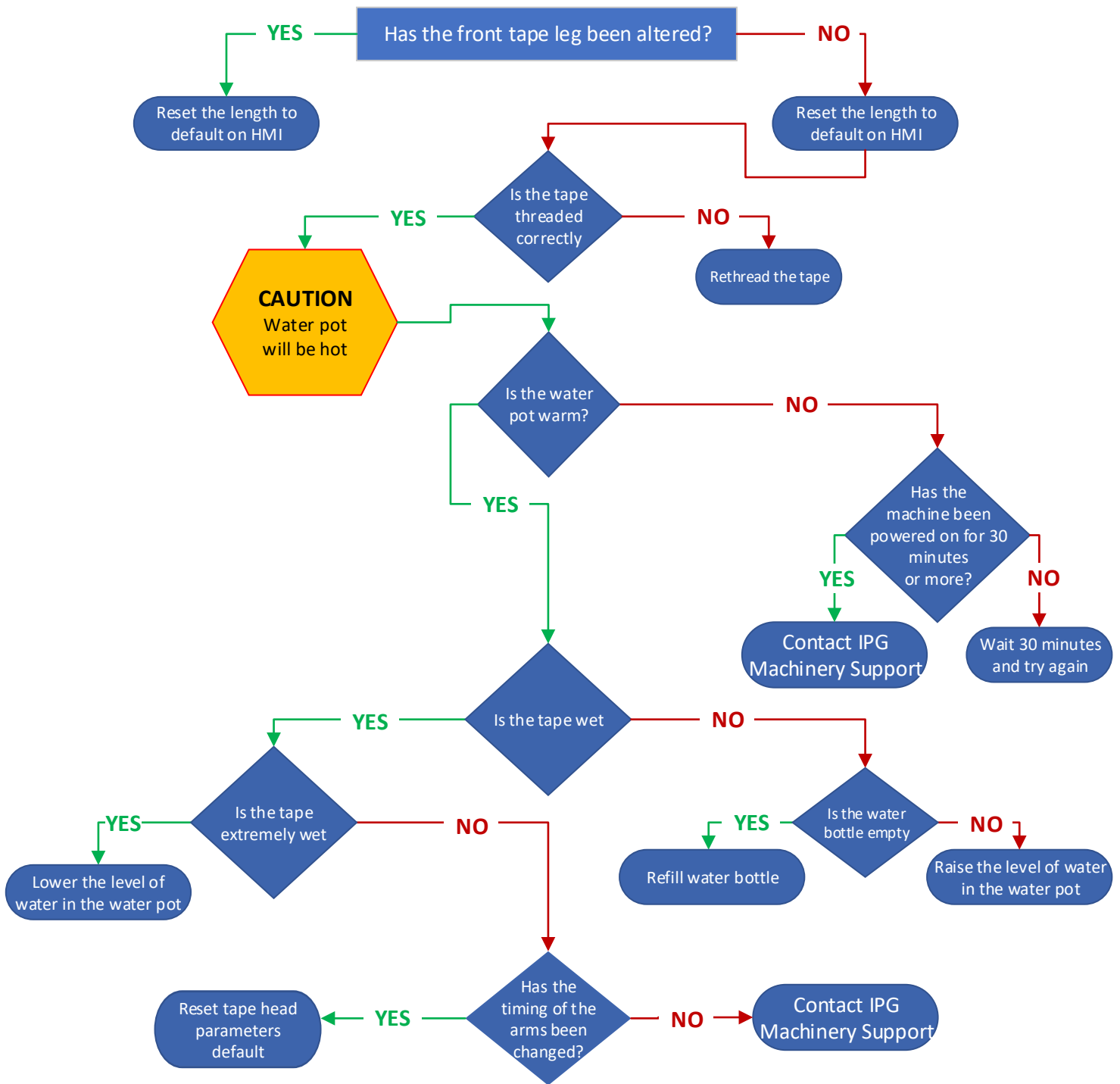
# TROUBLESHOOTING

## The Machine is Turned on and Nothing Happens



IPG Machinery Support  
877-447-4832 Option 4

## Front Tape Leg Not Sticking

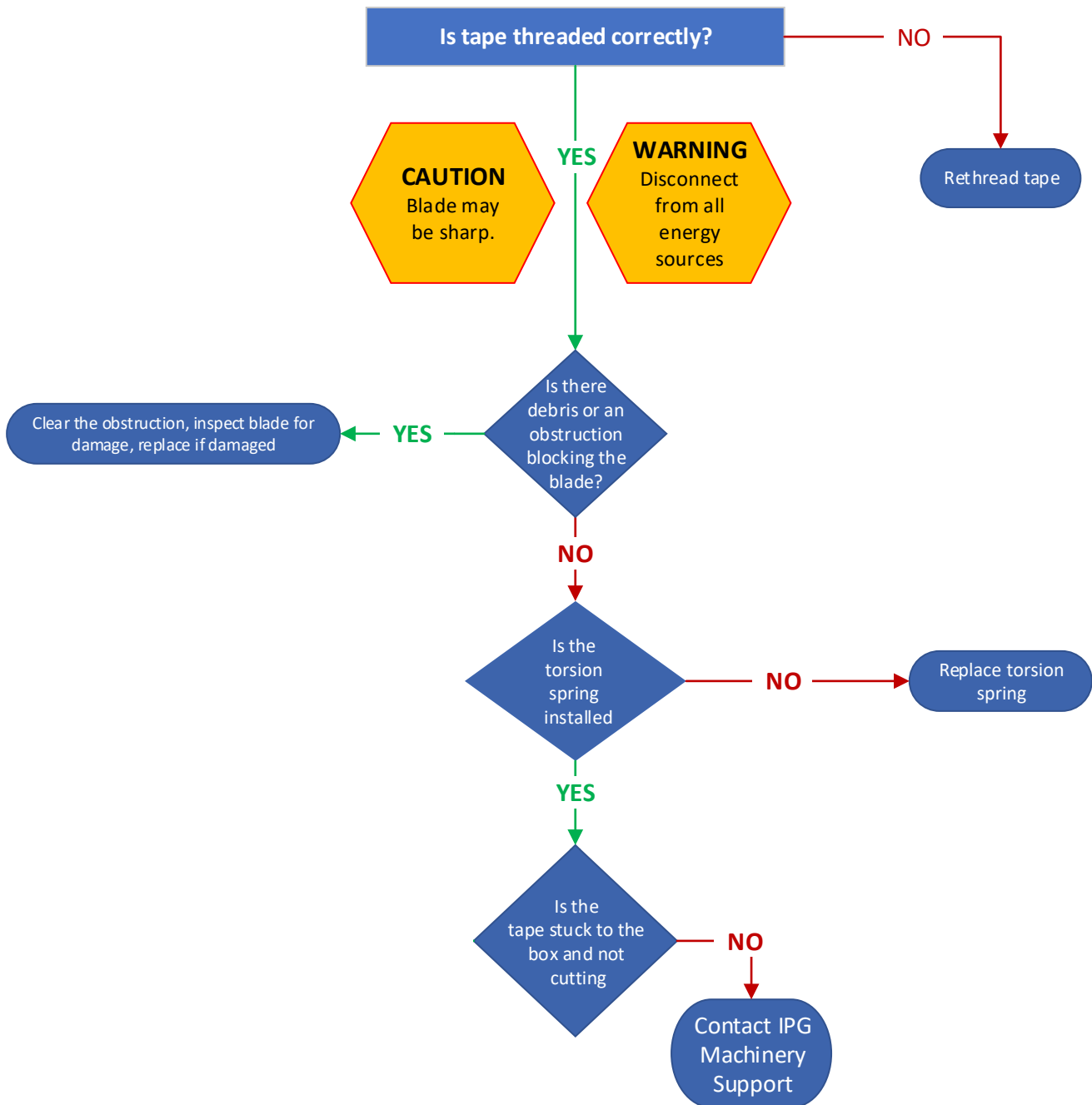


IPG Machinery Support  
877-447-4832 Option 4

## Rear Tape Leg Not Sticking

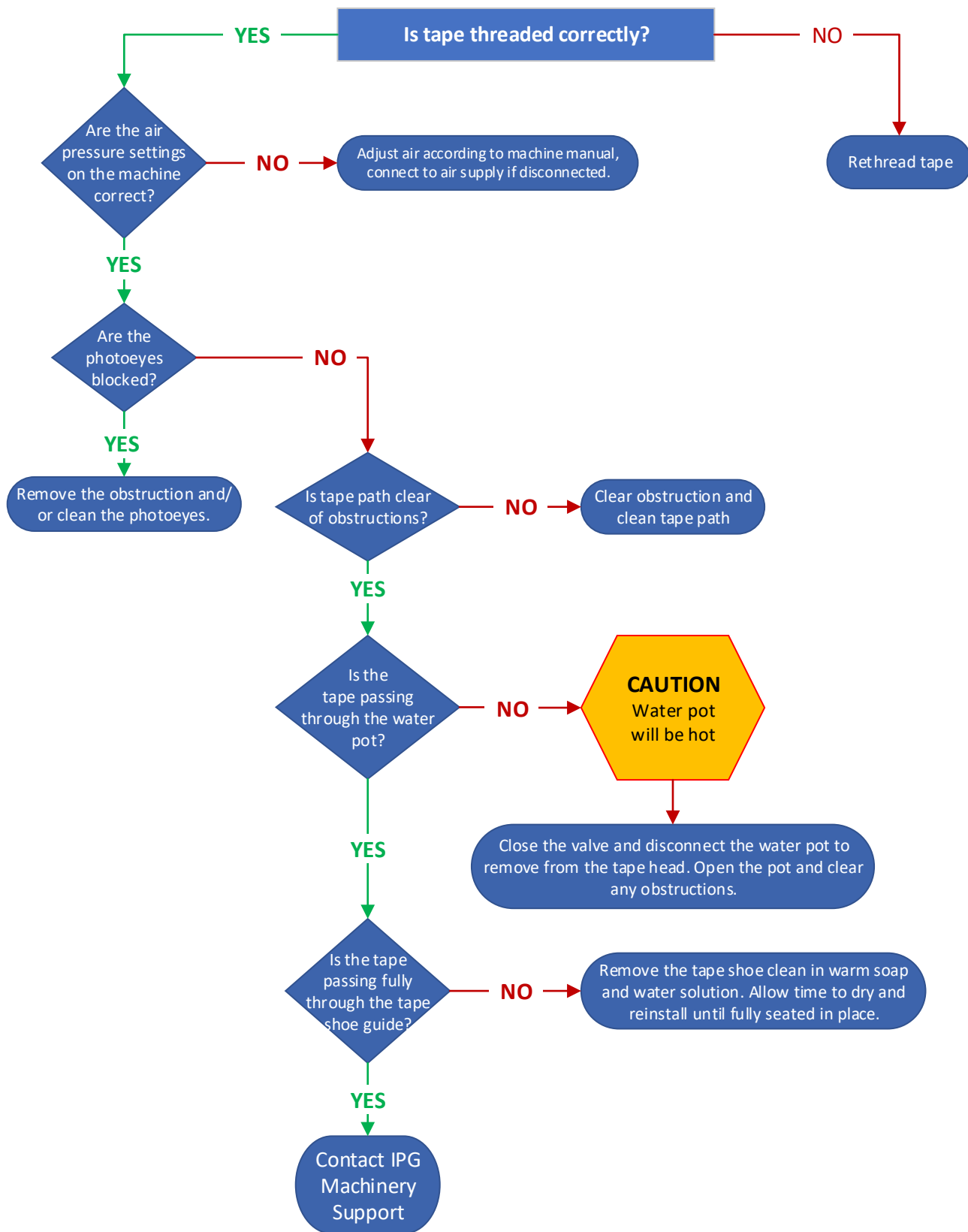


## Tape Does Not Cut



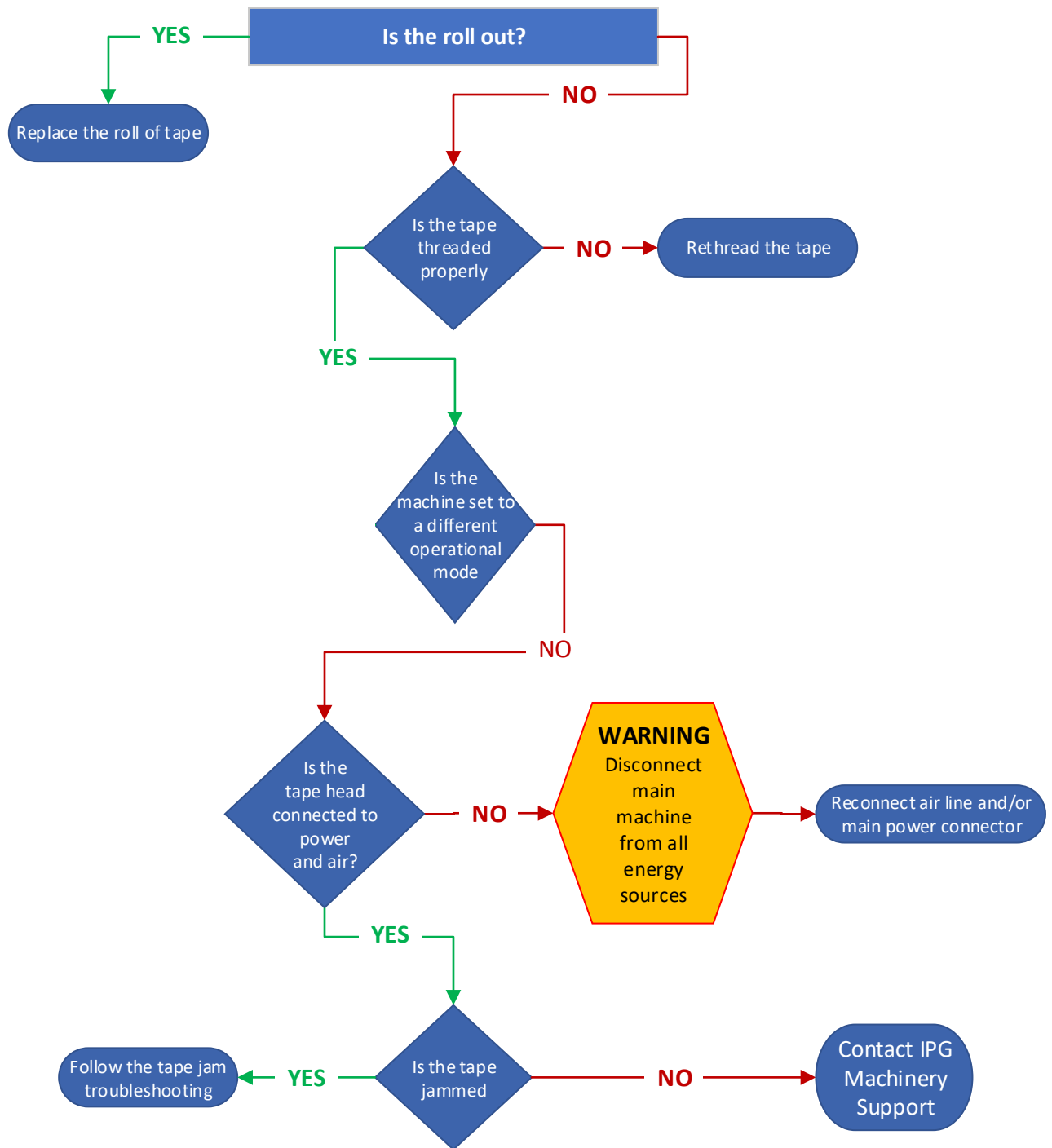
IPG Machinery Support  
877-447-4832 Option 4

## Tape Jam



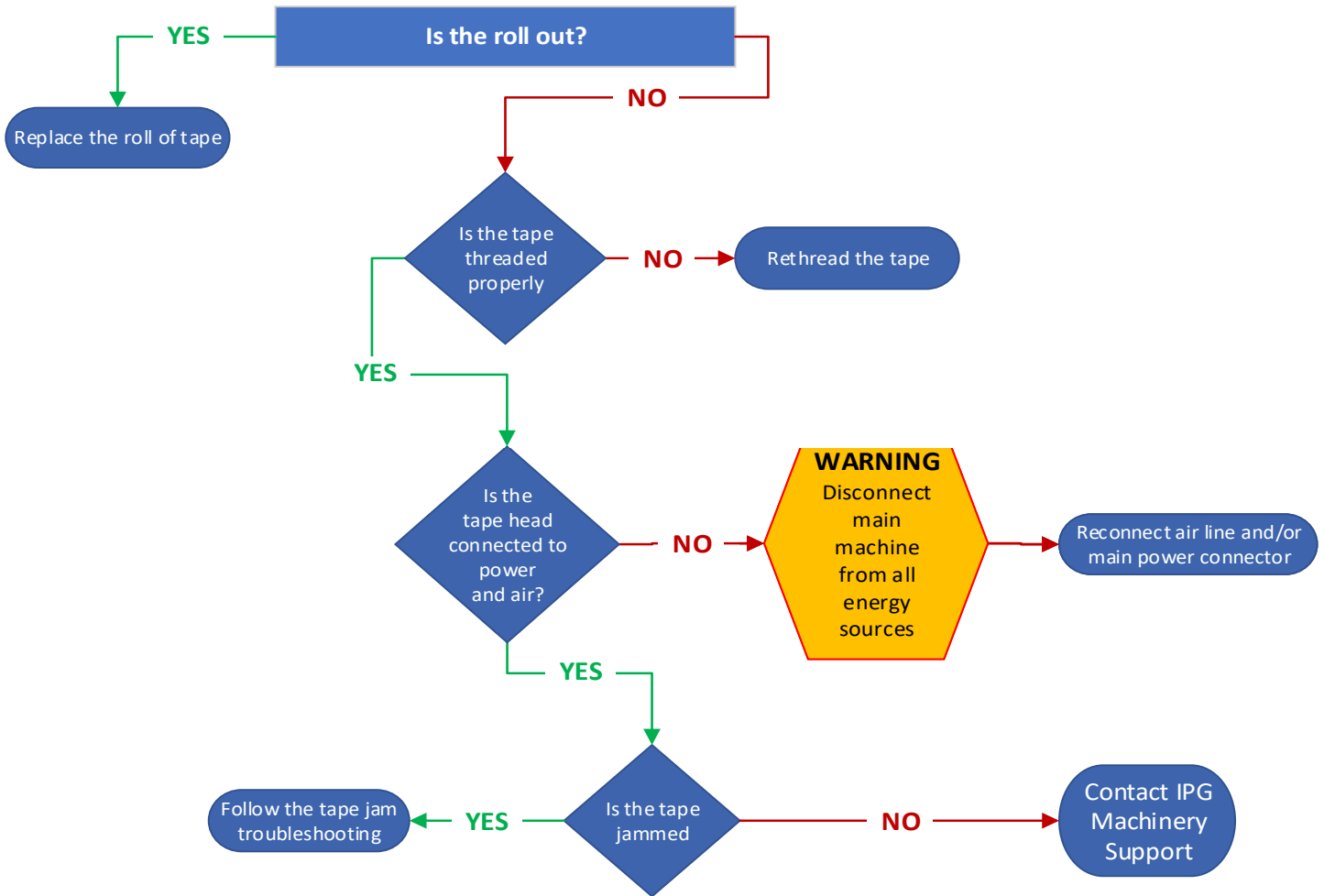
IPG Machinery Support  
877-447-4832 Option 4

## Wrinkles in the Tape



IPG Machinery Support  
877-447-4832 Option 4

## Tape Not Dispensed



IPG Machinery Support  
877-447-4832 Option 4

# MAINTENANCE

The **RSA 2626-WAT-TB Top Only** Case Sealer has been designed and manufactured with the finest components to provide long, trouble-free performance. General preventive maintenance will improve performance and prolong the life of the case sealer. Review the illustrations and chart below for information regarding machine maintenance.



**WARNING: DISCONNECT ALL ENERGY SOURCES AND LOCK OUT THE ELECTRICAL SUPPLY BEFORE CLEANING OR MAINTENANCE. IF POWER CORDS AND PNEUMATIC CONNECTIONS ARE NOT DISCONNECTED, SEVERE INJURY TO PERSONNEL COULD RESULT.**

## Lubrication:

Spray centering guide shafts, column shafts, and compression guide shafts once a month with a silicone based dry film lubricant. This will not attract dust or lint from the surroundings.

Apply chain lube on the drive chains once a month.

No other lubrication is necessary to operate the machine.

## Cleaning:

Cartons produce a sizable amount of dust and paper chips when processed or handled. If this dust is allowed to build up in the machine, it may cause component wear and overheating of motors. Remove the accumulated dust with a shop vacuum. Avoid using compressed air to remove the dust as this may cause the dust to penetrate into components.

Item	Action Required	Material	Frequency		
			Weekly	Monthly	Quarterly
Carton Dust In/On Machine	Vacuum off machine externally and internally, pay attention to drive base centering chain	Vacuum	X		
Hardware	Re-tighten any loose hardware, replace any missing hardware			X	
Cross Shafts	Lubricate	Dry PTFE		X	
Centering Chain	Lubricate	Chain Lubricant		X	
Air Regulator Filter	Clean filter	Water, Mild Detergent		X	
Tape Path	Clean to remove adhesive	Water, Mild Detergent	X		
Water Pot/Reservoir	Rinse out thoroughly	Water, Mild Detergent		X	
Wetting Roller	Clean roller	Water, Mild Detergent			
Wipe Down Drive Rollers	Remove dust	Air Hose	X		
Tape Head Assist Roller	Clean roller	Water, Mild Detergent	X		

## Recommended Spare Parts:

It is recommended to keep a small supply of spare parts on hand in order to reduce any potential down time for maintenance. The table of parts to the right is the recommended list of spare parts. Different applications of machinery may require some amendments to this list, please consult IPG Machinery Support for any additional recommended material.

Description	Item Number	QTY
Peel off Spring	UPM4498	1
Emergency Stop Button	<a href="#">UPM2211</a>	1
Driving Belts Top	UPM6888	2
Driving Belts Bottom	UPM6887	2
Water Pot Roller	<a href="#">WET0071</a>	1
WAT Tape Head Roller	WPT0144	2
Striker Plate	<a href="#">WPT0044</a>	1
Cutter Blade	<a href="#">WPT0050</a>	1

# MAINTENANCE

## Changing the Air Regulator Filter

The filter on the air regulator removes dirt and moisture from supplied air before it enters the carton sealer.

1. To remove metal protective guard, press down on locking tab located towards the top of the guard, rotate guard and pull down.
2. The clear reservoir has a threaded top, which is used to attach it to the main regulator assembly. To remove the reservoir, rotate it until unfastened.
3. The air regulator filter is held in place using a threaded cap fastened on to the main assembly. To remove the filter, unfasten the cap and pull down on filter.

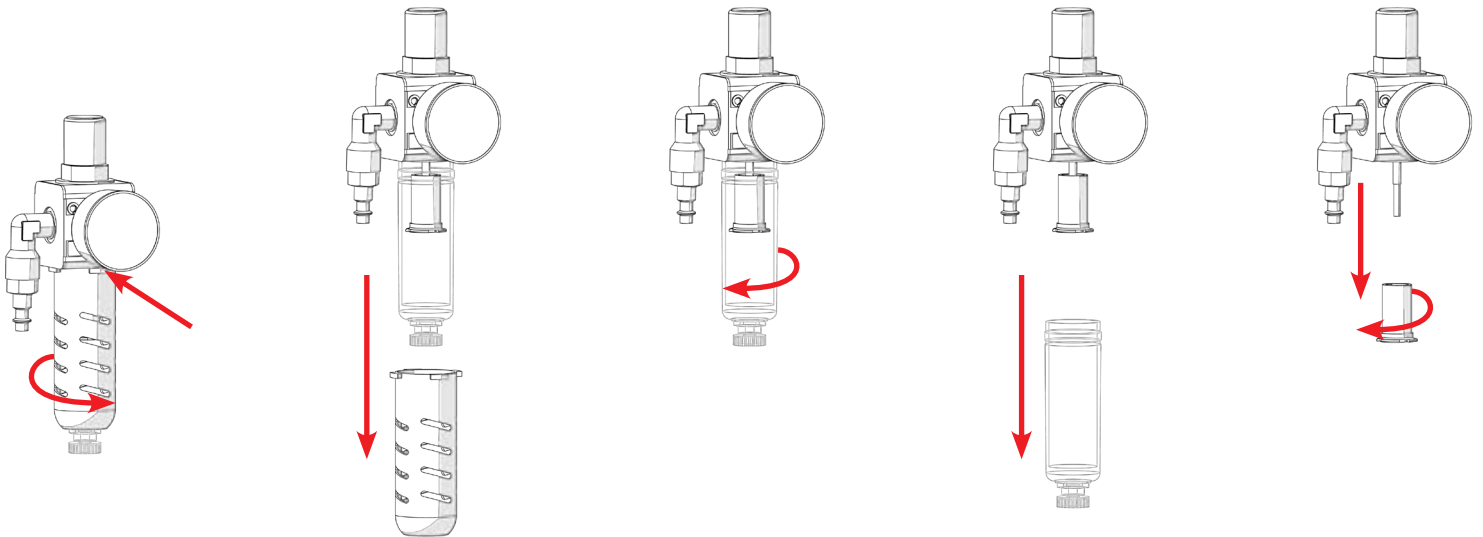
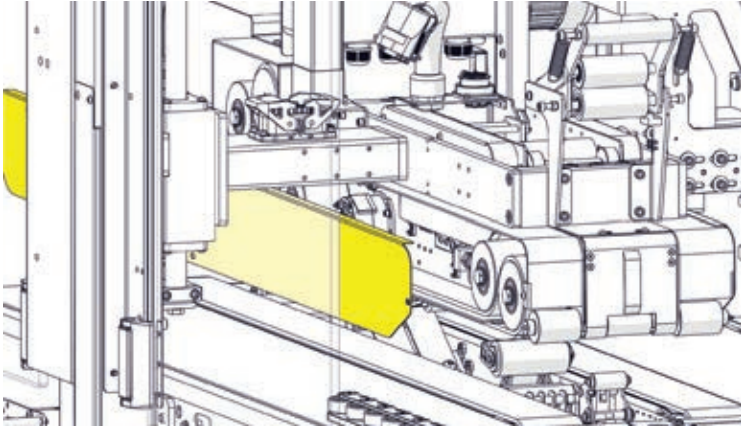


Figure 85: Pneumatic Filter

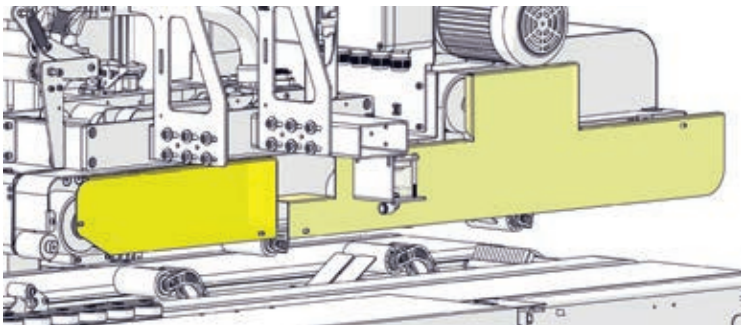
# MAINTENANCE

## Top Drive Belt Replacement

1. If removing the left side cover, use a 4mm Allen key to remove the three (3) screws. If removing the two (2) right side covers use a 4mm Allen key to remove the four (4) screws.

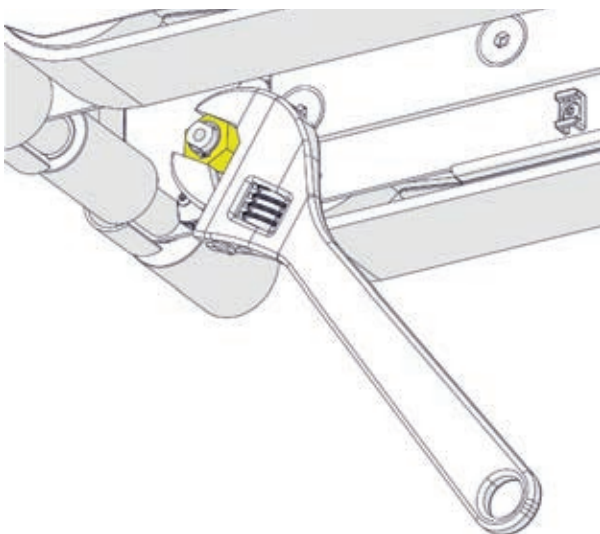


**Figure 86: Top Left Cover Removal**



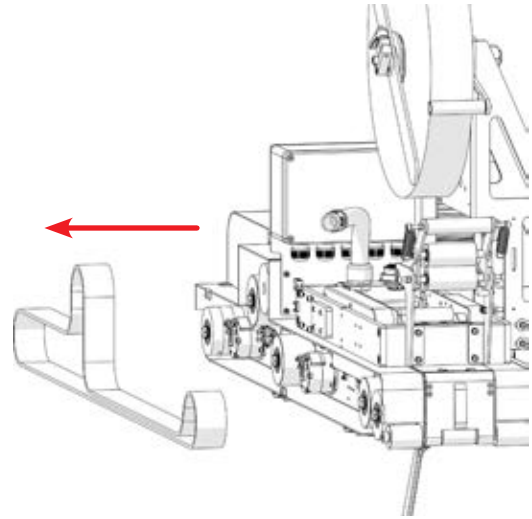
**Figure 87: Top Right Cover Removal**

2. Use a wrench to loosen the cam allowing slack into the belt.



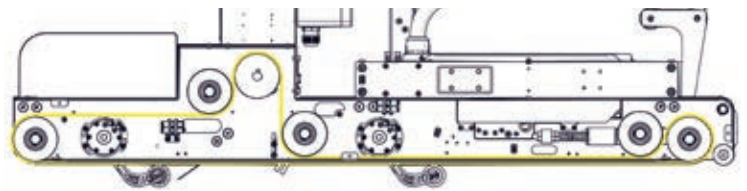
**Figure 88: Belt Loosening**

3. While the belt is loosened remove the worn belt from the bridge.



**Figure 89: Top Belt Removal**

4. Replace the belt following the below belt webbing.



**Figure 90: Top Belt Webbing**

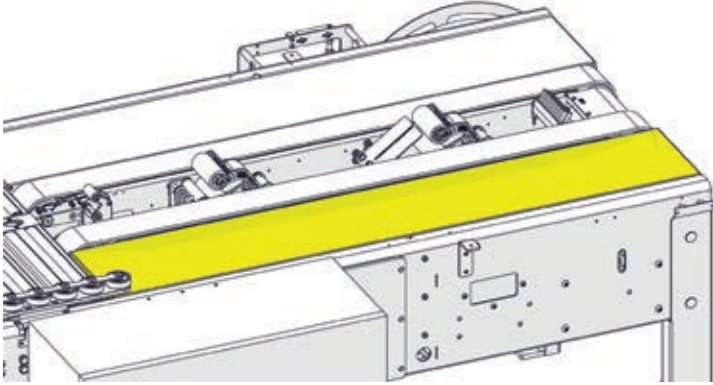
5. Remove the slack on the belt.
6. Replace the side cover(s).

# MAINTENANCE

## Bottom Drive Belt Replacement

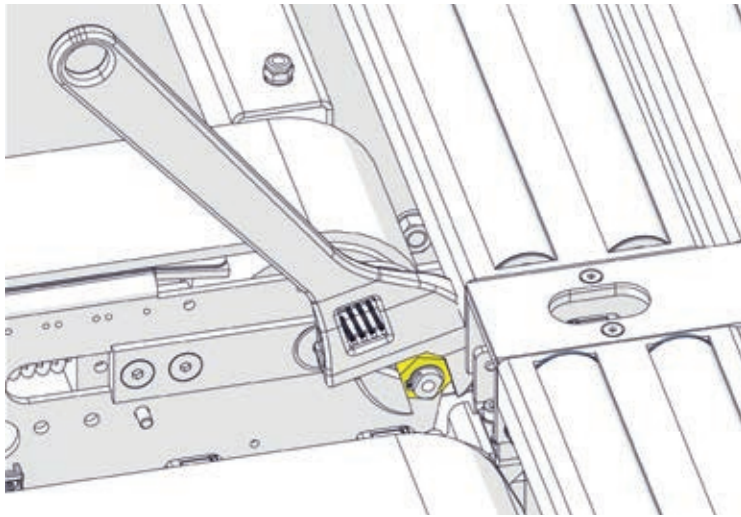
The bridge, columns, and doors have been removed from the graphics to aid in visuals.

1. Remove the stainless steel cover.



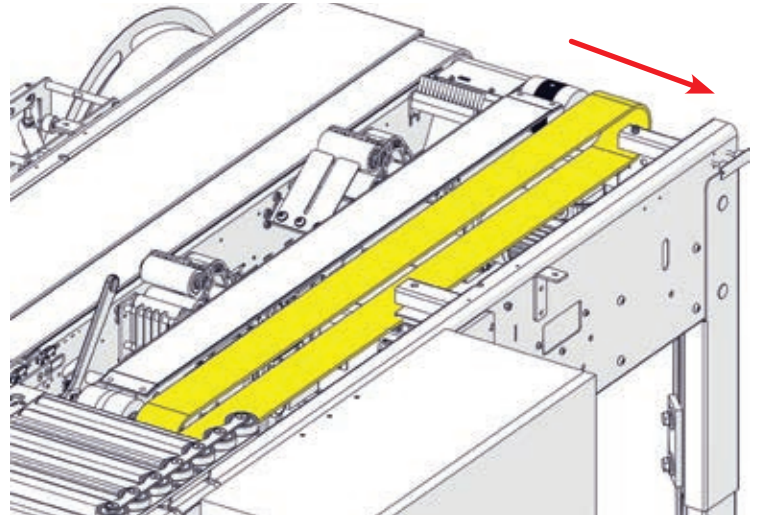
**Figure 91: Bottom Cover Removal**

2. Use a wrench to loosen the cam to introduce slack in the belt.



**Figure 92: Bottom Belt Loosening**

3. Remove the worn belt.

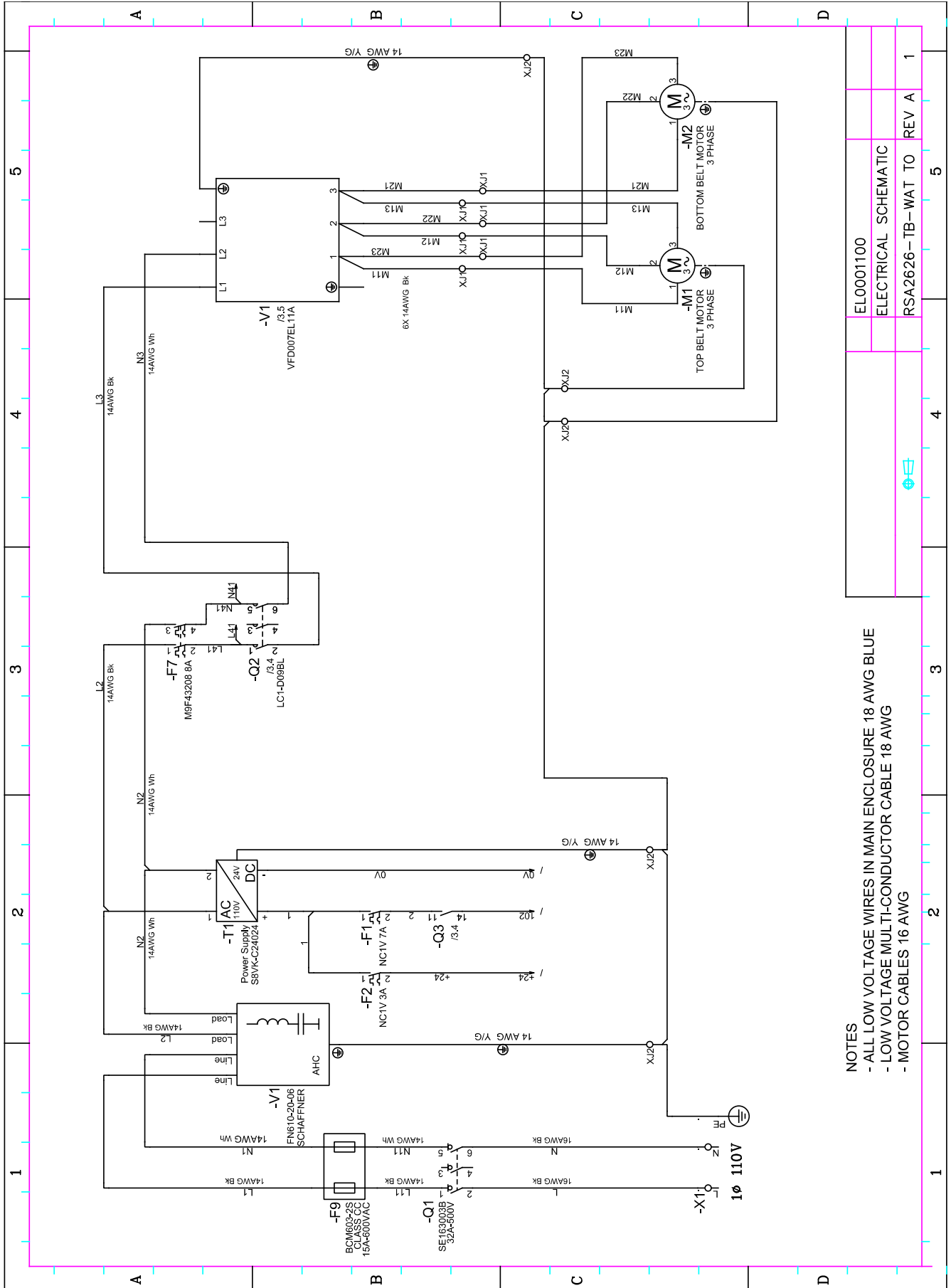


**Figure 93: Machine Settings Screen**

4. Replace the belt.
5. Remove the slack from the belt.
6. Replace the cover.

# APPENDIX A

## Electrical Drawing

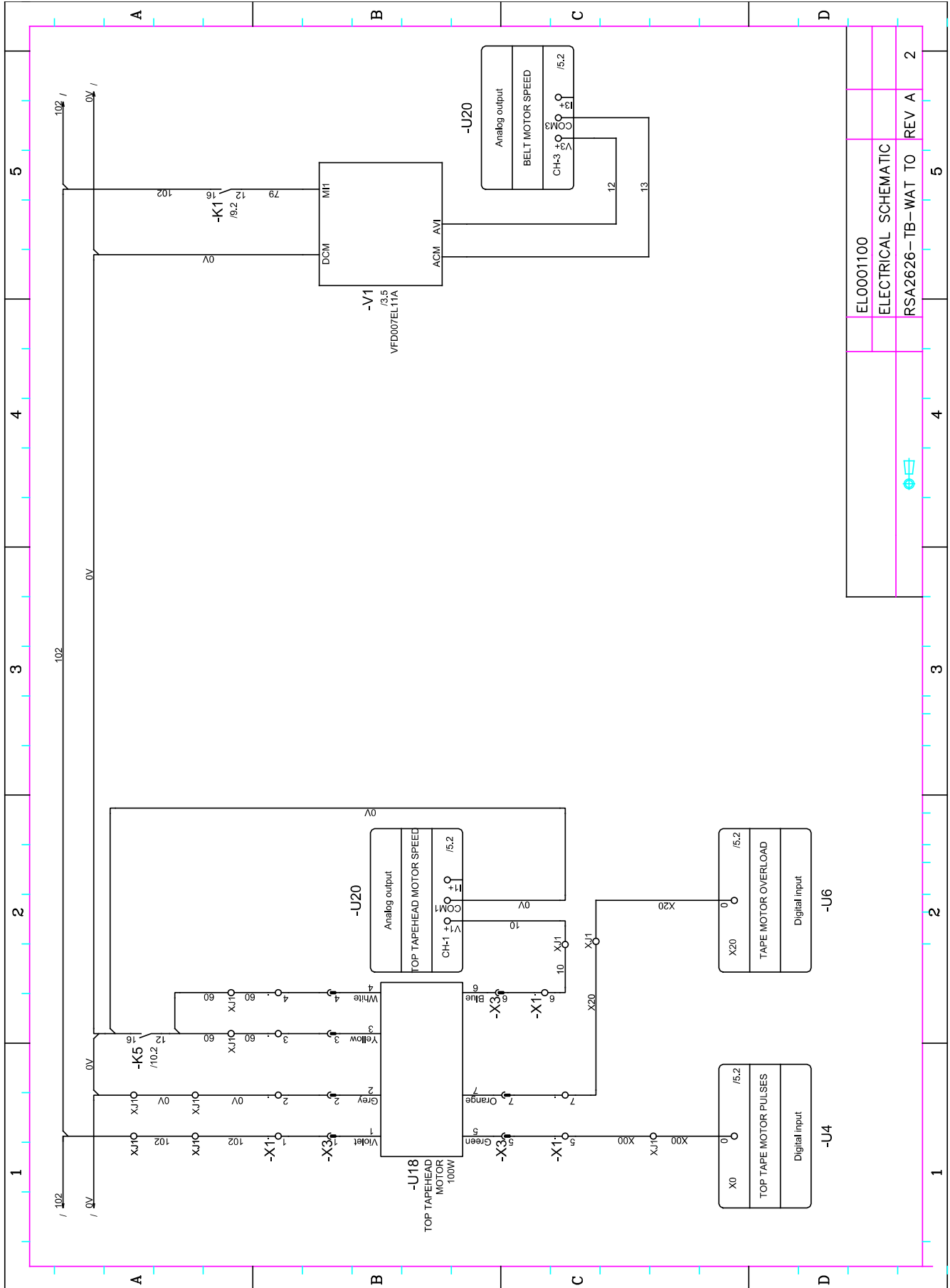


NOTES  
 - ALL LOW VOLTAGE WIRES IN MAIN ENCLOSURE 18 AWG BLUE  
 - LOW VOLTAGE MULTI-CONDUCTOR CABLE 18 AWG  
 - MOTOR CABLES 16 AWG

EL0001100
ELECTRICAL SCHEMATIC
RSA2626-TB-WAT TO REV A 1

# APPENDIX A

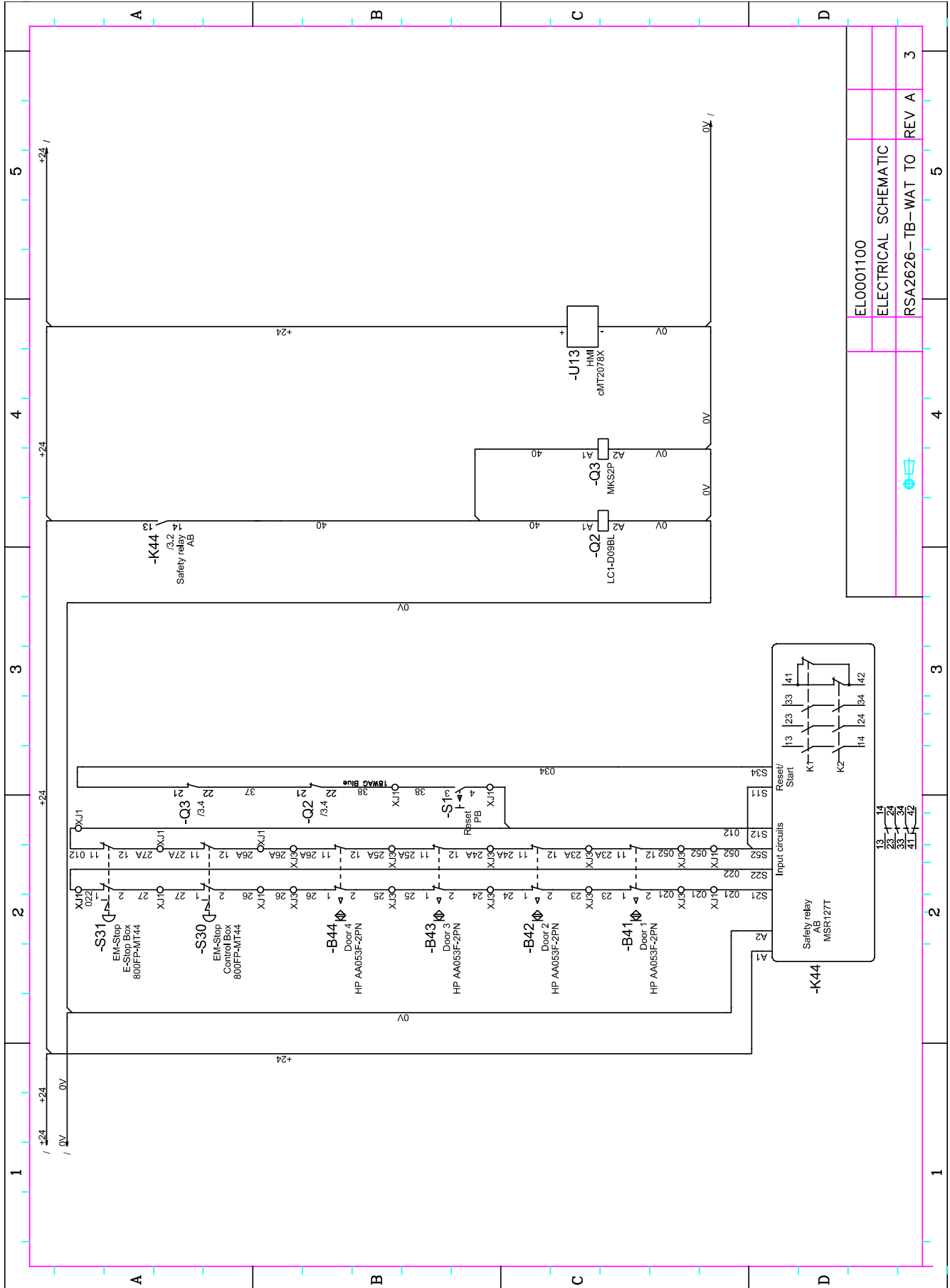
## Electrical Drawing



EL0001100					
ELECTRICAL SCHEMATIC					
RSA2626 - TB-WAT TO					
REV A					2

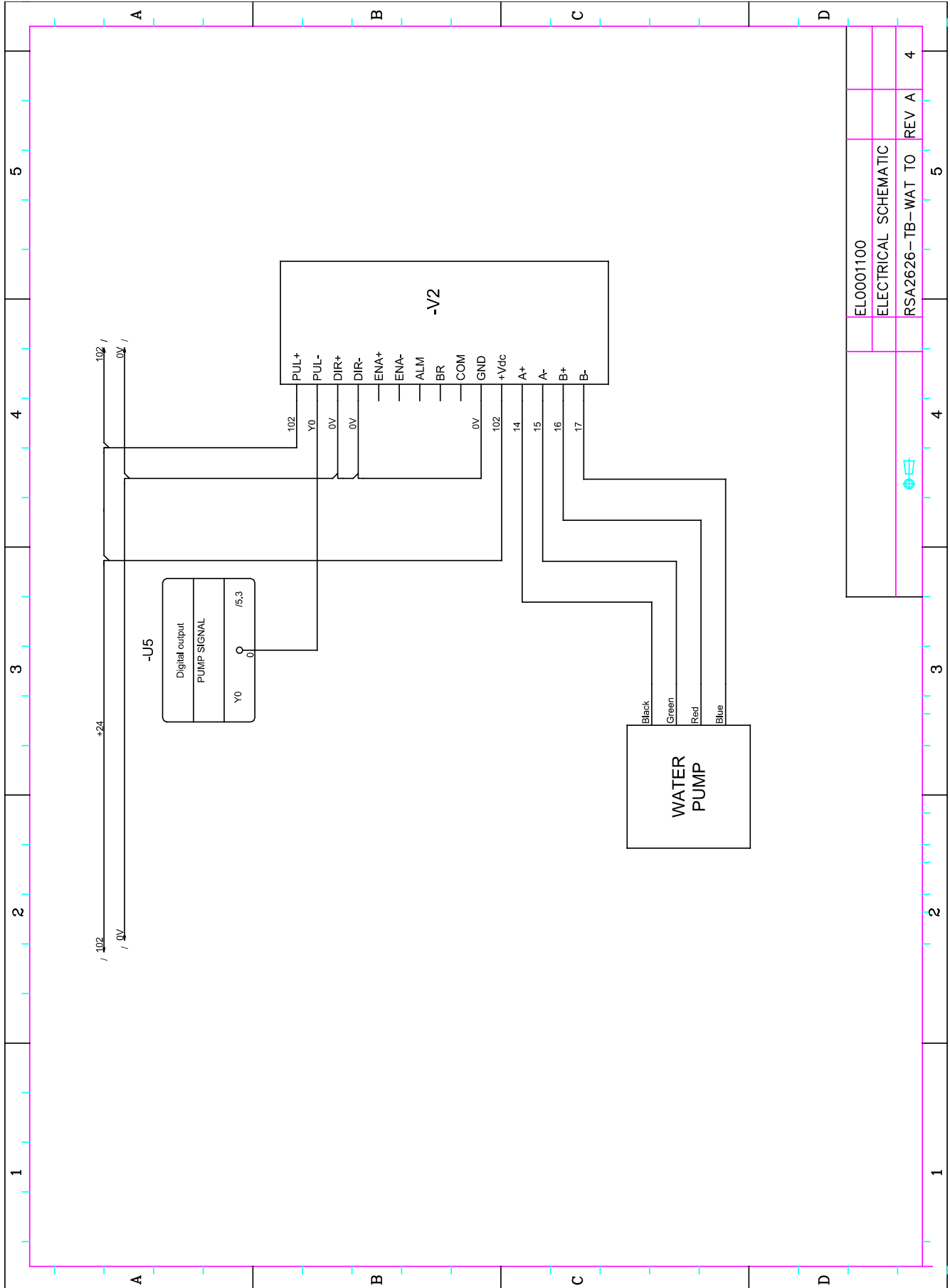
# APPENDIX A

## Electrical Drawing



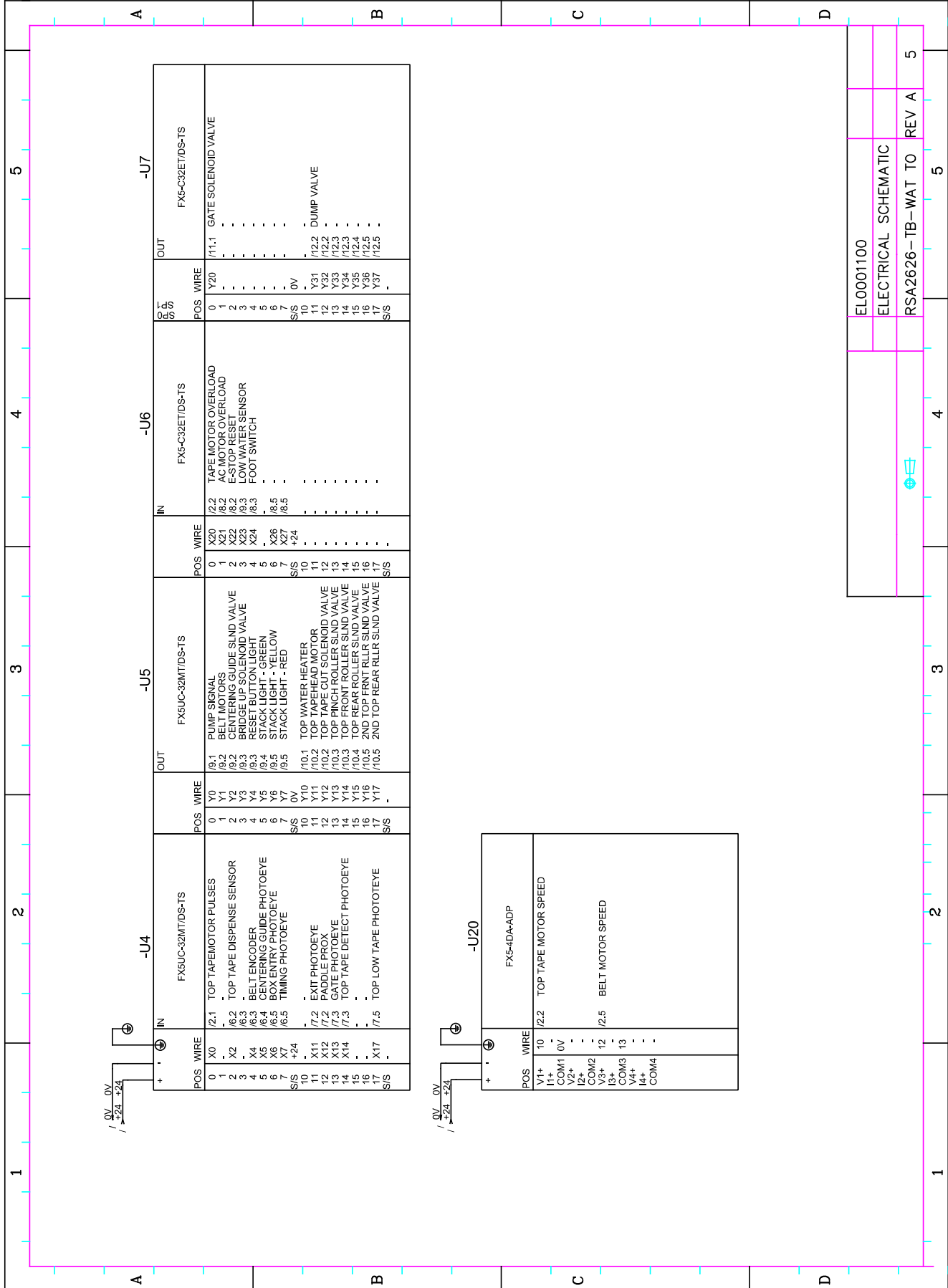
# APPENDIX A

## Electrical Drawing



# APPENDIX A

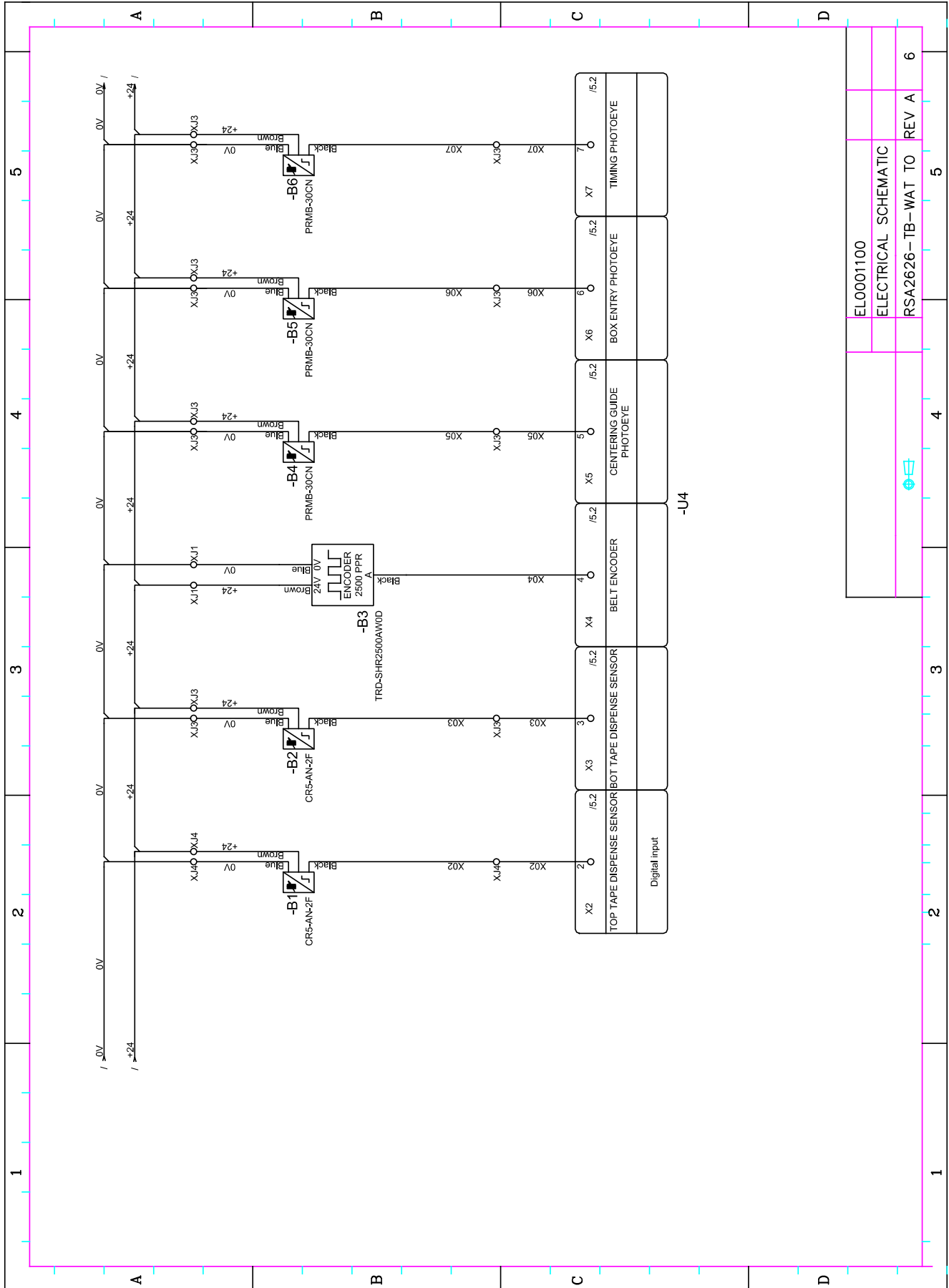
## Electrical Drawing



ELO001100					
ELECTRICAL SCHEMATIC					
RSA2626-TB-WAT TO					
REV A					5

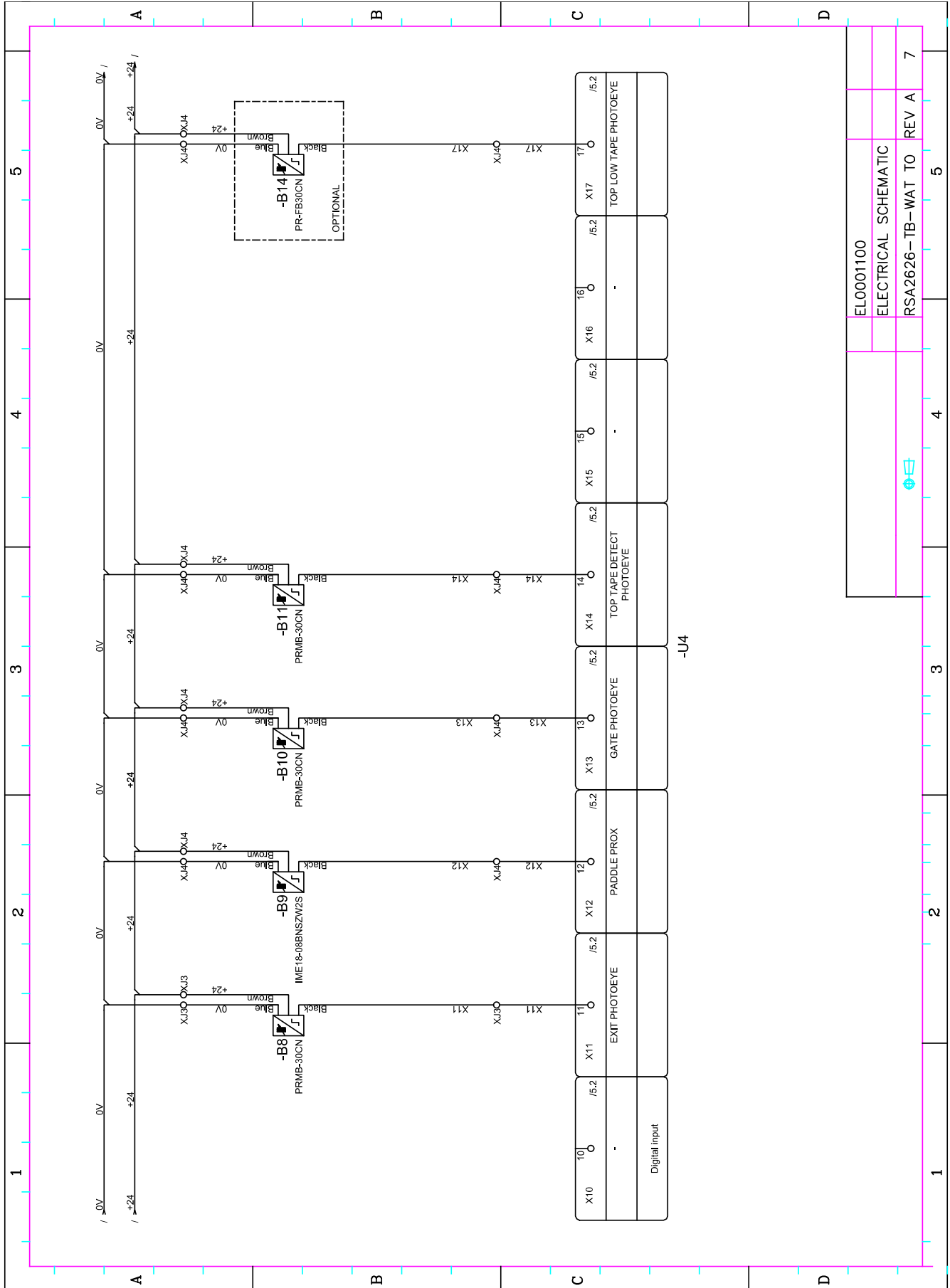
# APPENDIX A

## Electrical Drawing



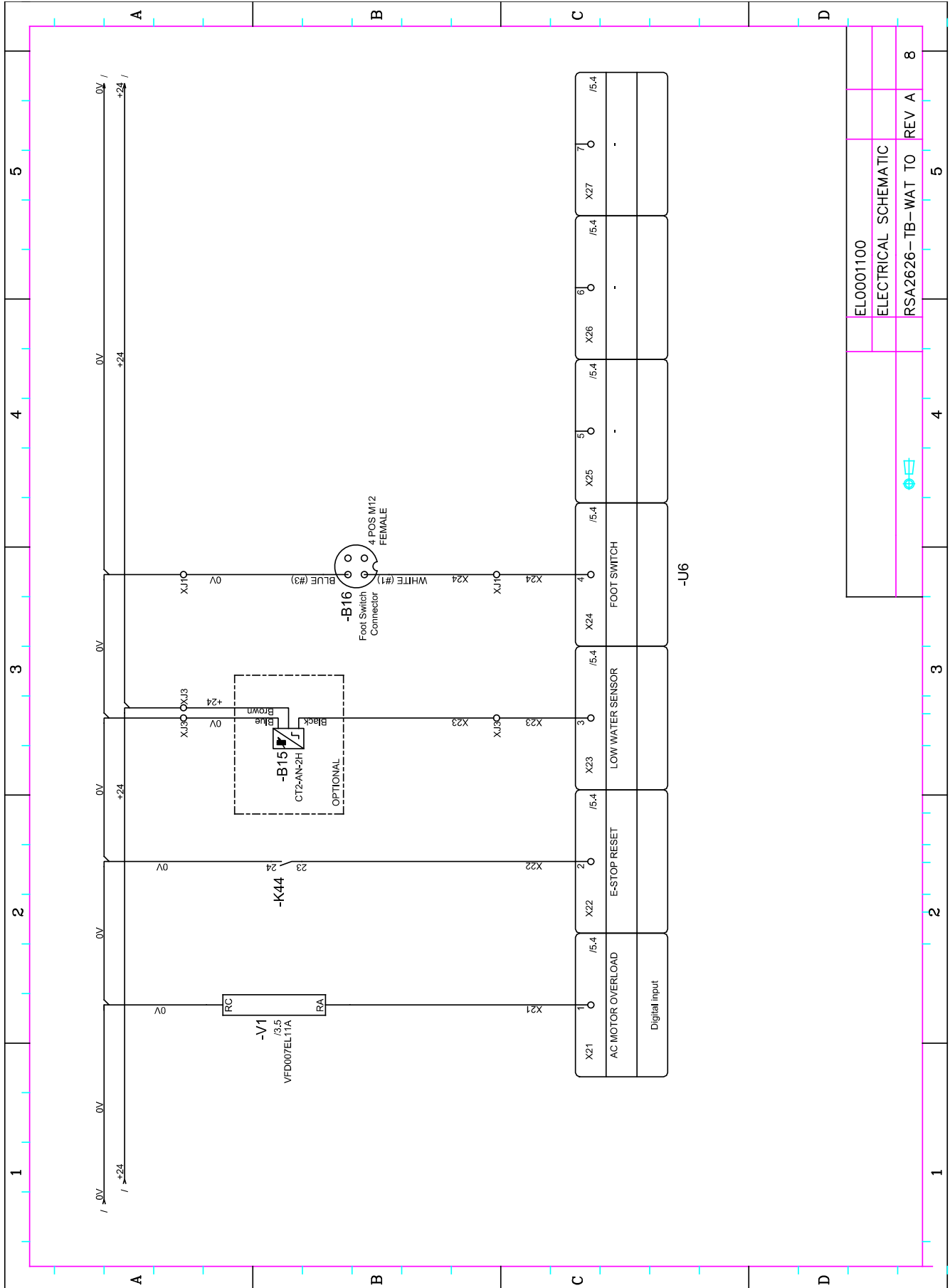
# APPENDIX A

## Electrical Drawing



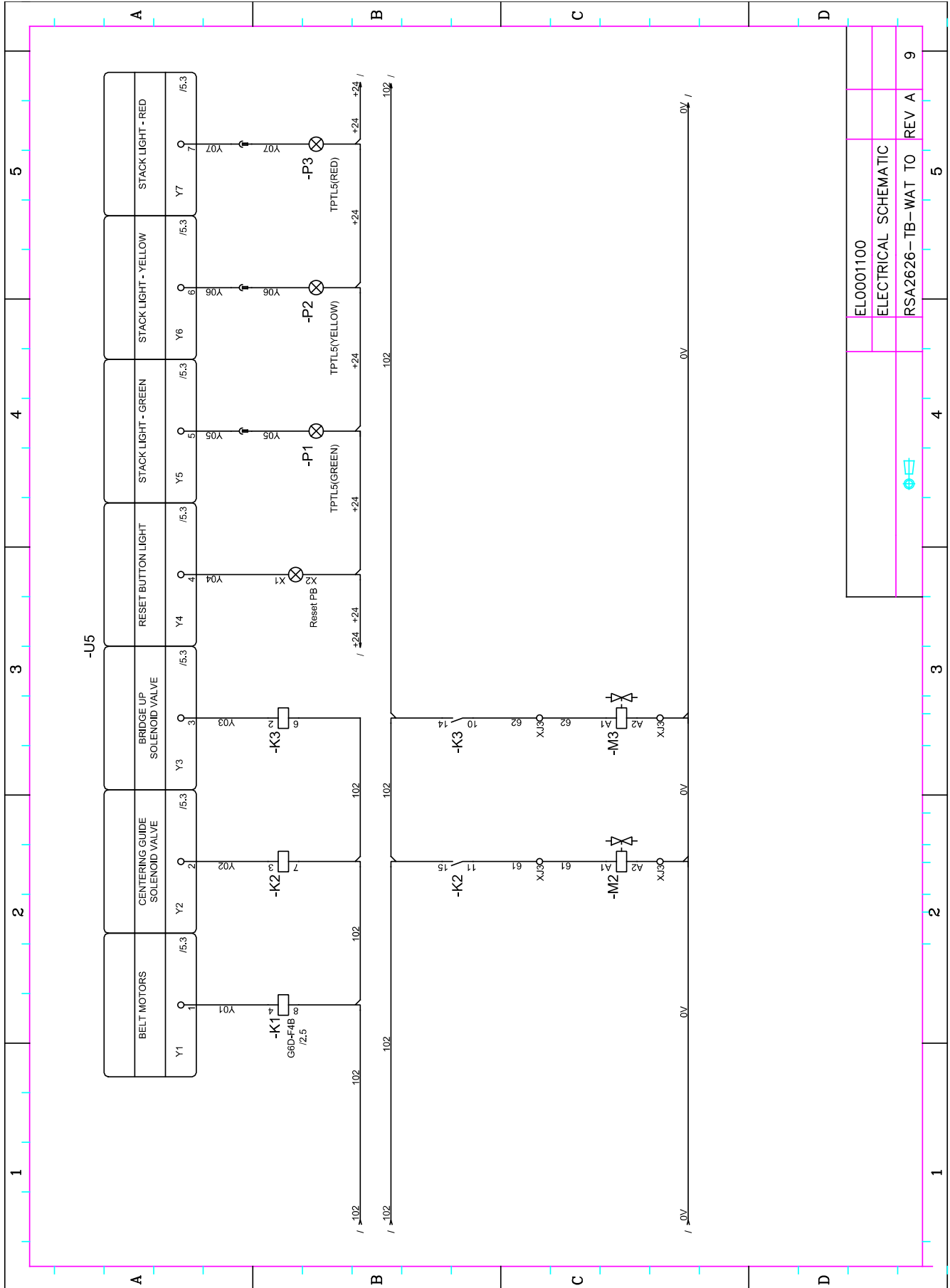
# APPENDIX A

## Electrical Drawing



# APPENDIX A

## Electrical Drawing

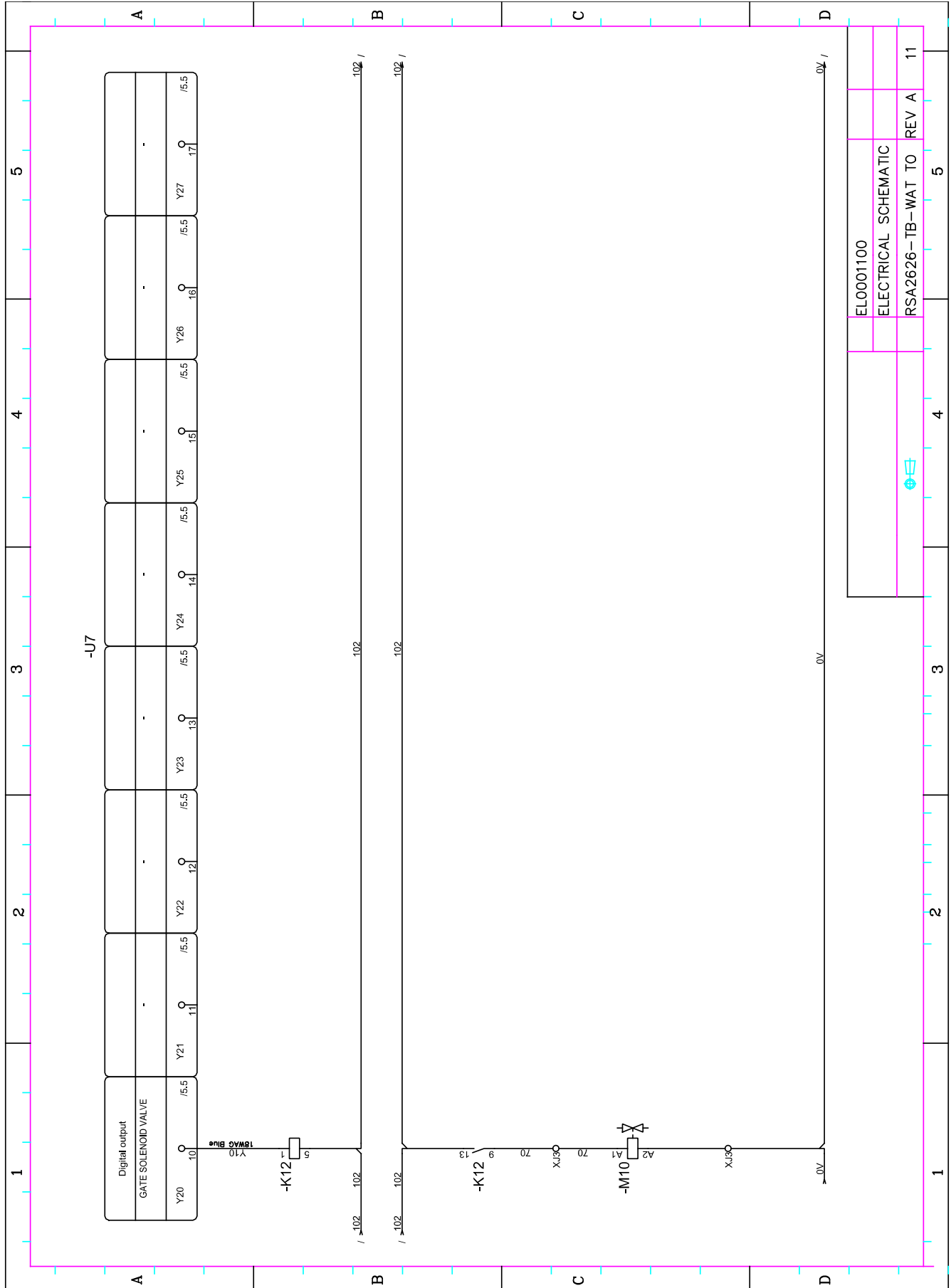


ELO001100					
ELECTRICAL SCHEMATIC					
RSA2626 - TB-WAT TO					
REV A					



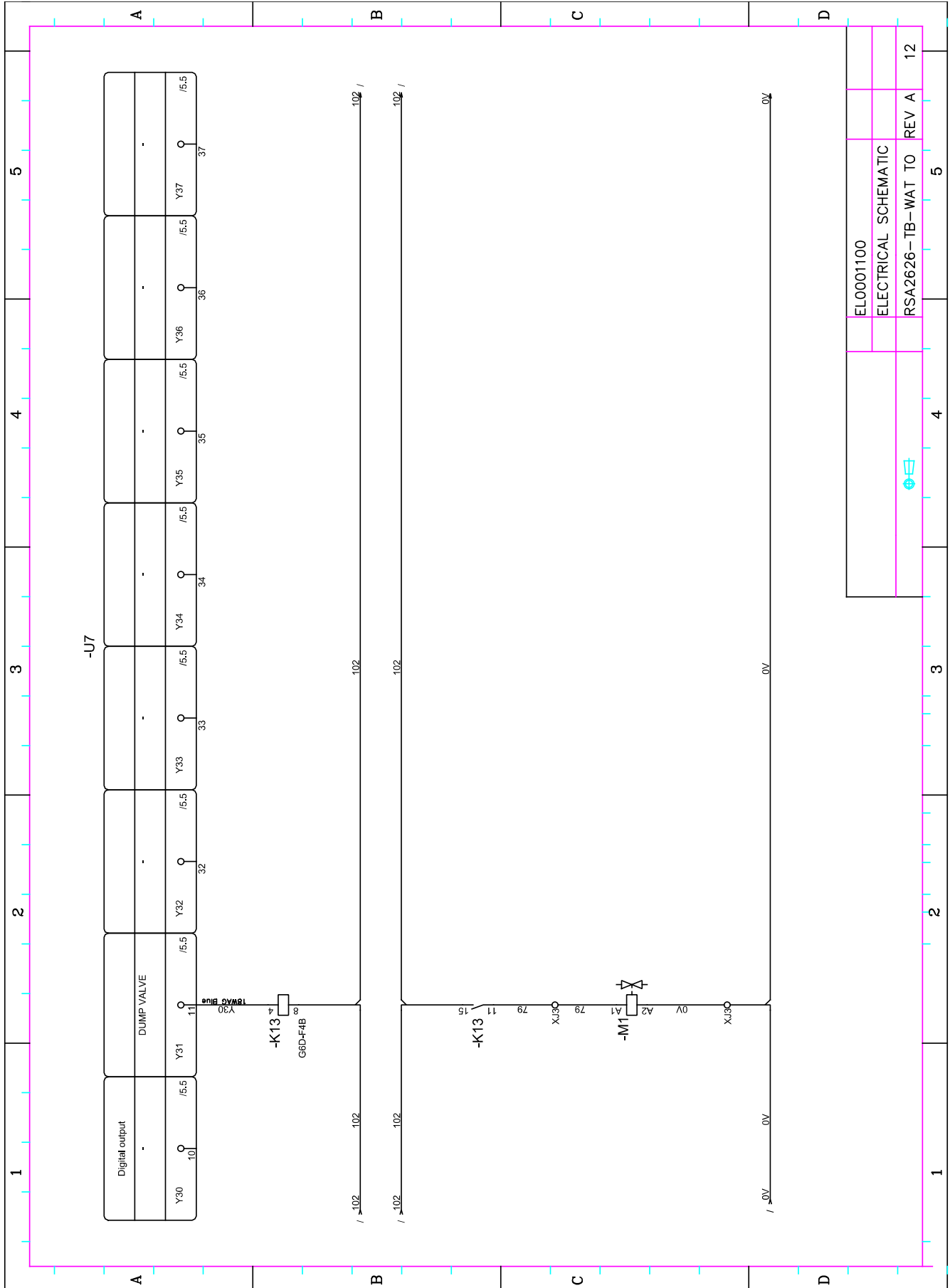
# APPENDIX A

## Electrical Drawing



# APPENDIX A

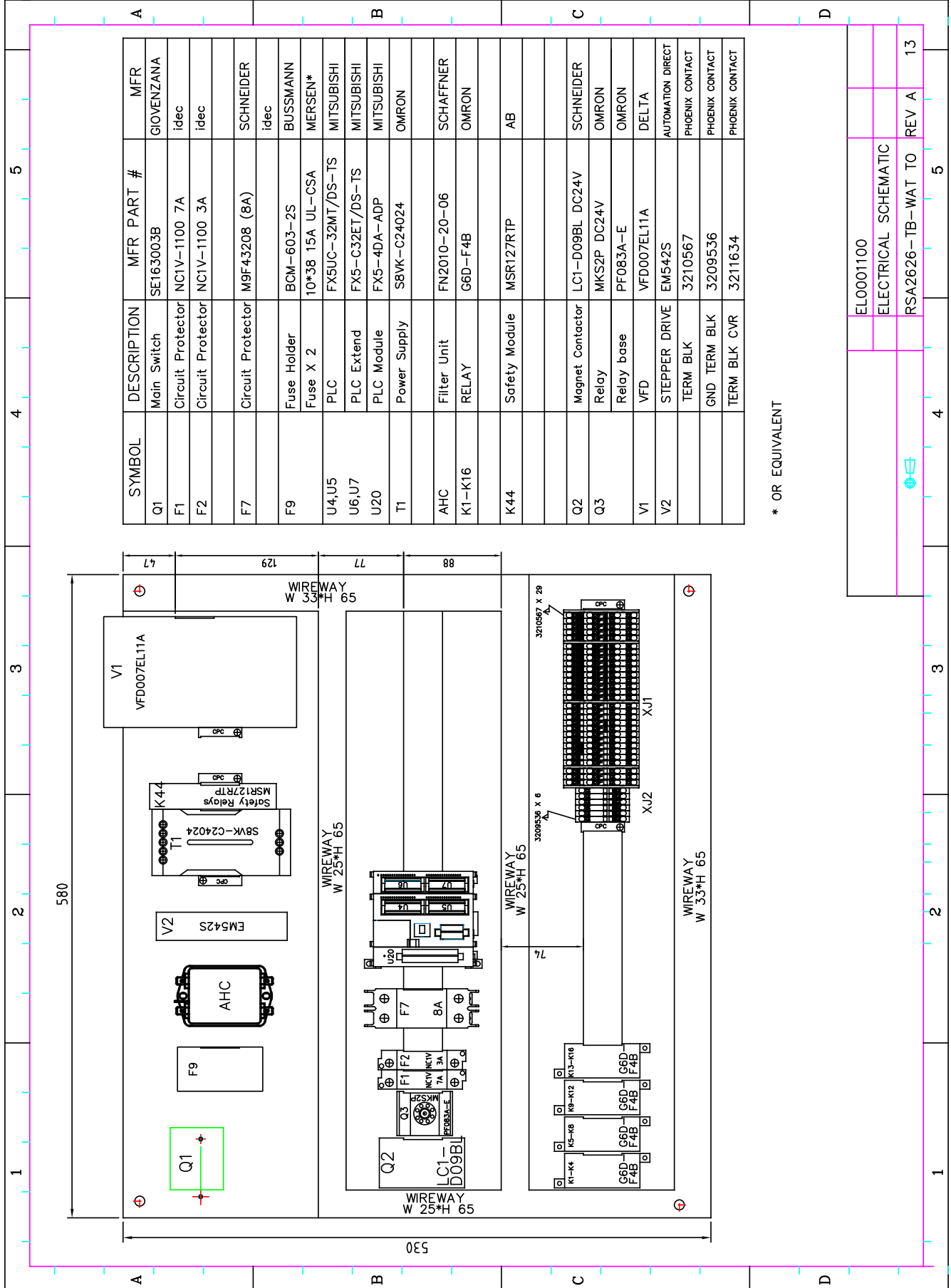
## Electrical Drawing



ELO001100					
ELECTRICAL SCHEMATIC					
RSA2626 - TB-WAT TO					
REV A					12

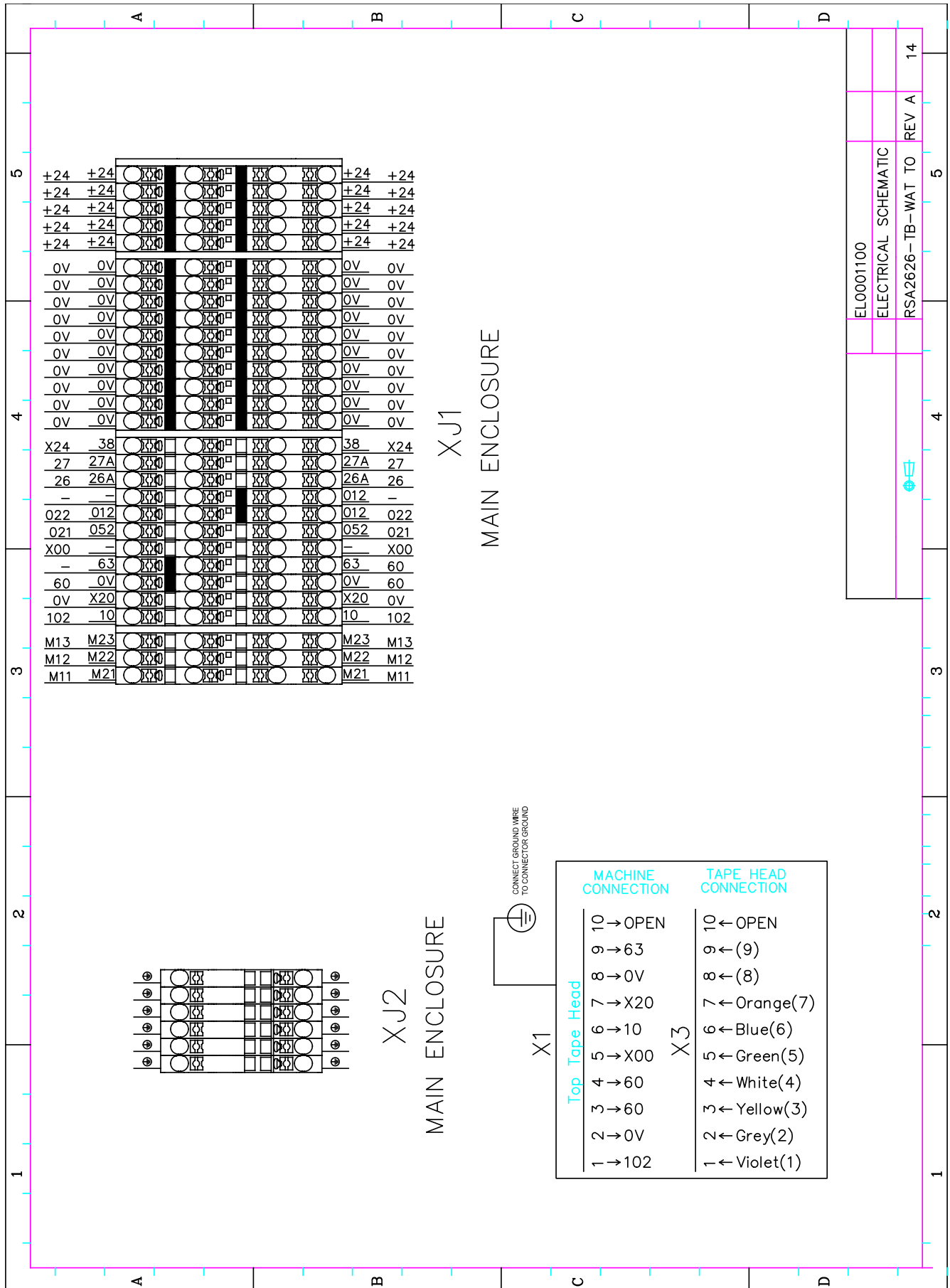
# APPENDIX A

## Electrical Drawing



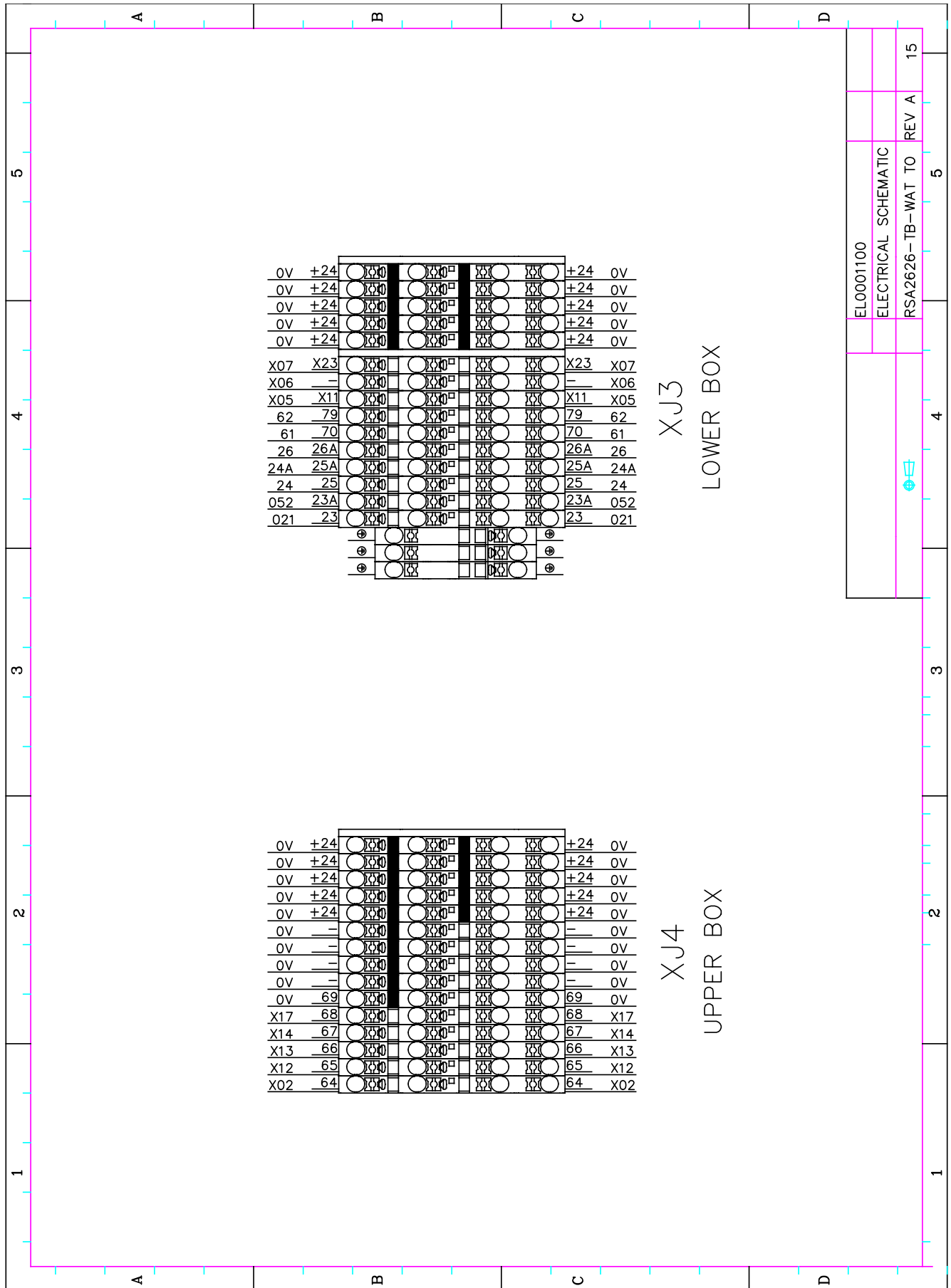
# APPENDIX A

## Electrical Drawing



# APPENDIX A

## Electrical Drawing





# APPENDIX A

## Pneumatic Drawing

PN0001075

REVISIONS

NOTE:



RSA2626-TB-WAT TOP ONLY  
PNEUMATIC SCHEMATIC

FILE: -

USED ON: RSA2626-TB-WAT TOP ONLY

ENG BY: DGW DATE: 2024-11-06

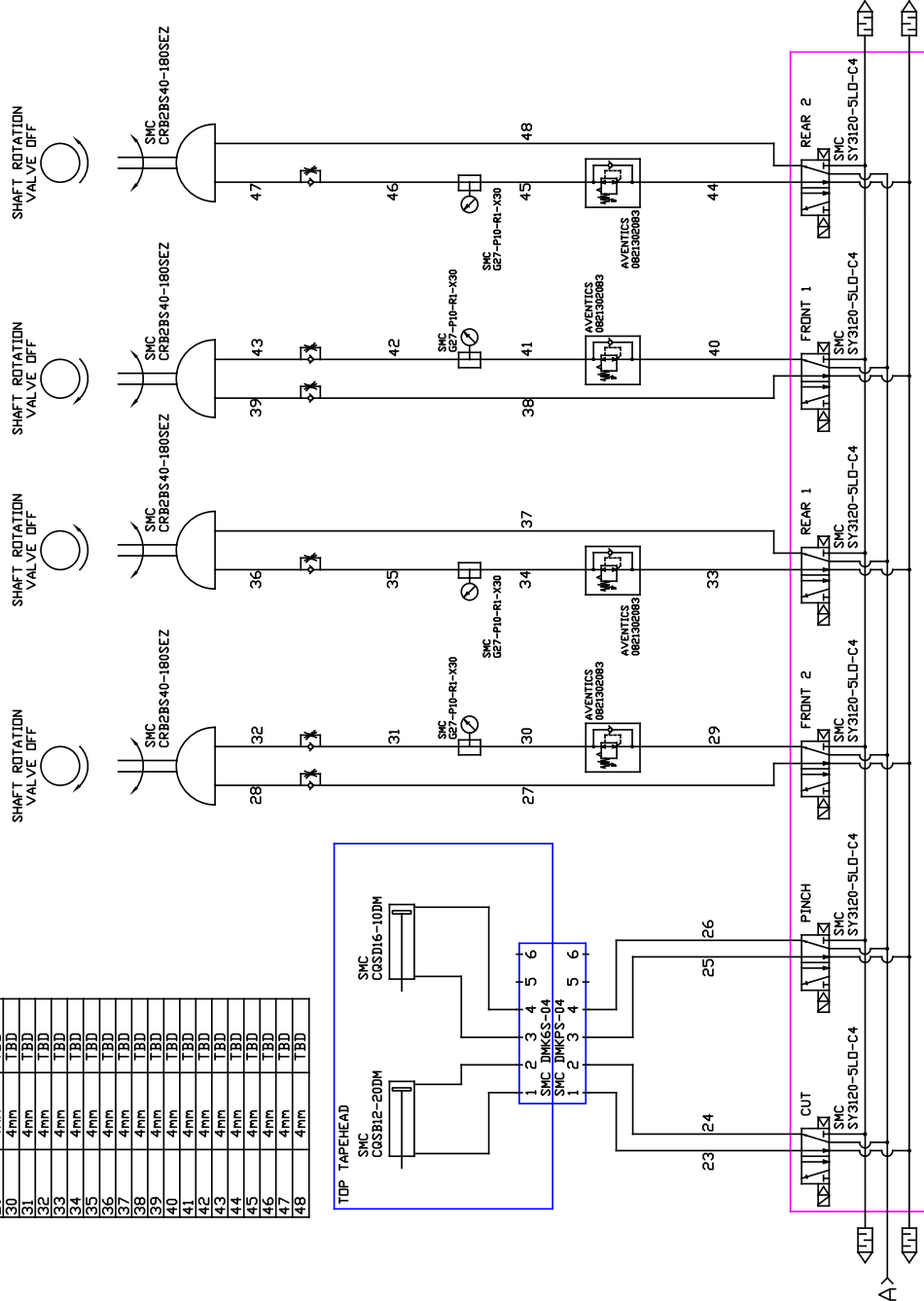
DWN BY: DGW REV: C

SHEET 2 OF 3

SIZE A

- NOTES:
- APPLY LABELS TO TUBES
  - APPLY LABELS TO BOTH ENDS IF TUBE IS LONG OR TUBE IS PART OF A BUNDLE
  - SHAFT ROTATION FACING OUTPUT SHAFT SIDE OF ACTUATOR


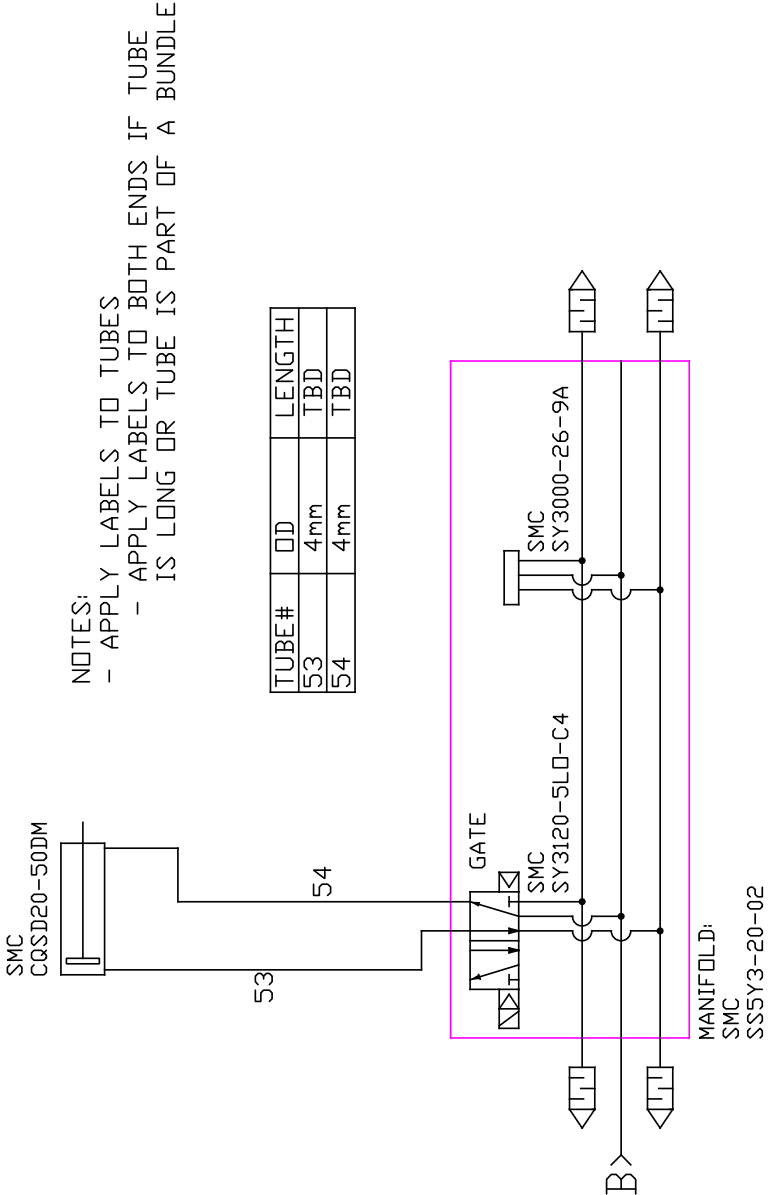
TUBE#	OD	LENGTH
23	4mm	TBD
24	4mm	TBD
25	4mm	TBD
26	4mm	TBD
27	4mm	TBD
28	4mm	TBD
29	4mm	TBD
30	4mm	TBD
31	4mm	TBD
32	4mm	TBD
33	4mm	TBD
34	4mm	TBD
35	4mm	TBD
36	4mm	TBD
37	4mm	TBD
38	4mm	TBD
39	4mm	TBD
40	4mm	TBD
41	4mm	TBD
42	4mm	TBD
43	4mm	TBD
44	4mm	TBD
45	4mm	TBD
46	4mm	TBD
47	4mm	TBD
48	4mm	TBD



MANIFOLD:  
SMC  
SS313-20-06

# APPENDIX A

## Pneumatic Drawing

PN0001075	REVISIONS	NOTE:		RSA2626-TB-WAT TOP ONLY PNEUMATIC SCHEMATIC FILE: - USED ON: RSA2626-TB-WAT TOP ONLY ENG BY: DGW      DATE: 2024-11-06 DWN BY: DGW      REV: C SHEET 3 OF 3      SIZE A									
<p>NOTES:</p> <ul style="list-style-type: none"> <li>- APPLY LABELS TO TUBES</li> <li>- APPLY LABELS TO BOTH ENDS IF TUBE IS LONG OR TUBE IS PART OF A BUNDLE</li> </ul>													
<table border="1" style="margin: auto;"> <thead> <tr> <th>TUBE#</th> <th>OD</th> <th>LENGTH</th> </tr> </thead> <tbody> <tr> <td>53</td> <td>4mm</td> <td>TBD</td> </tr> <tr> <td>54</td> <td>4mm</td> <td>TBD</td> </tr> </tbody> </table>					TUBE#	OD	LENGTH	53	4mm	TBD	54	4mm	TBD
TUBE#	OD	LENGTH											
53	4mm	TBD											
54	4mm	TBD											
													

# APPENDIX B

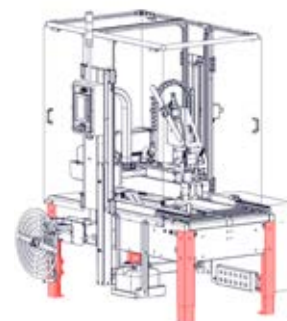
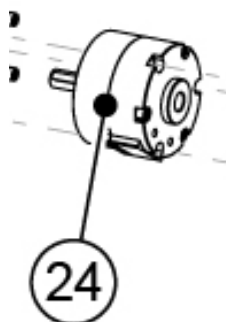
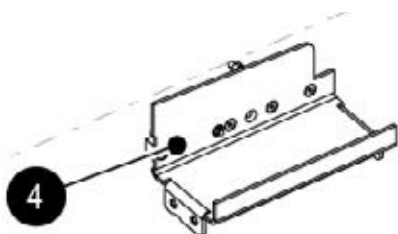
## Parts Listing

Main Machine	101	Top Left Drive	124
Base Frame	102	Top Right Drive	125
Drag Chains	103	Top Left Drive Frame	126
Legs	104	Top Right Drive Frame	127
Centering Assembly 1	105	Front Paddle	128
Centering Assembly 2	106	Top Tape Mandrel	129
Centering Assembly 3	107	Top Clutch Assembly	130
Roller Table	108	Top Pneumatic Valve Assembly	131
Bottom Drive Belts	109	Top Water Cup	132
Bottom Drive Turnbar	110	Top Sub-Electrical Box	133
Bottom Drive Right Frame	111	Top Tapehead Left Hardware 1	134
Bottom Drive Left Frame	112	Top Tapehead Belt Assembly	135
Bottom Drive Motor	113	Top Tapehead Right Hardware	136
Gate	114	Top Tapehead Drive Assembly	137
Bottom Sub-Electrical Box	115	Top Tapehead Cutting Assembly	138
Main Electrical Cabinet	116	Top Tapehead Left Hardware 2	139
Electrical Cabinet Components	117	Top Tapehead Electrical Assembly	140
Main Pneumatic Assembly	118	Top Tapehead Frames	141
Operator Controls	119	Top Tape Chute	142
Left Column	120	Top Water Pot	143
Right Column	121	Water Supply Assembly	144
Bridge Cover Panels	122	Guarding	145
Bridge Support Assembly	123		

Items with black balloon call outs are assemblies (made of more than one individual part).

Items with white balloon call outs are single parts.

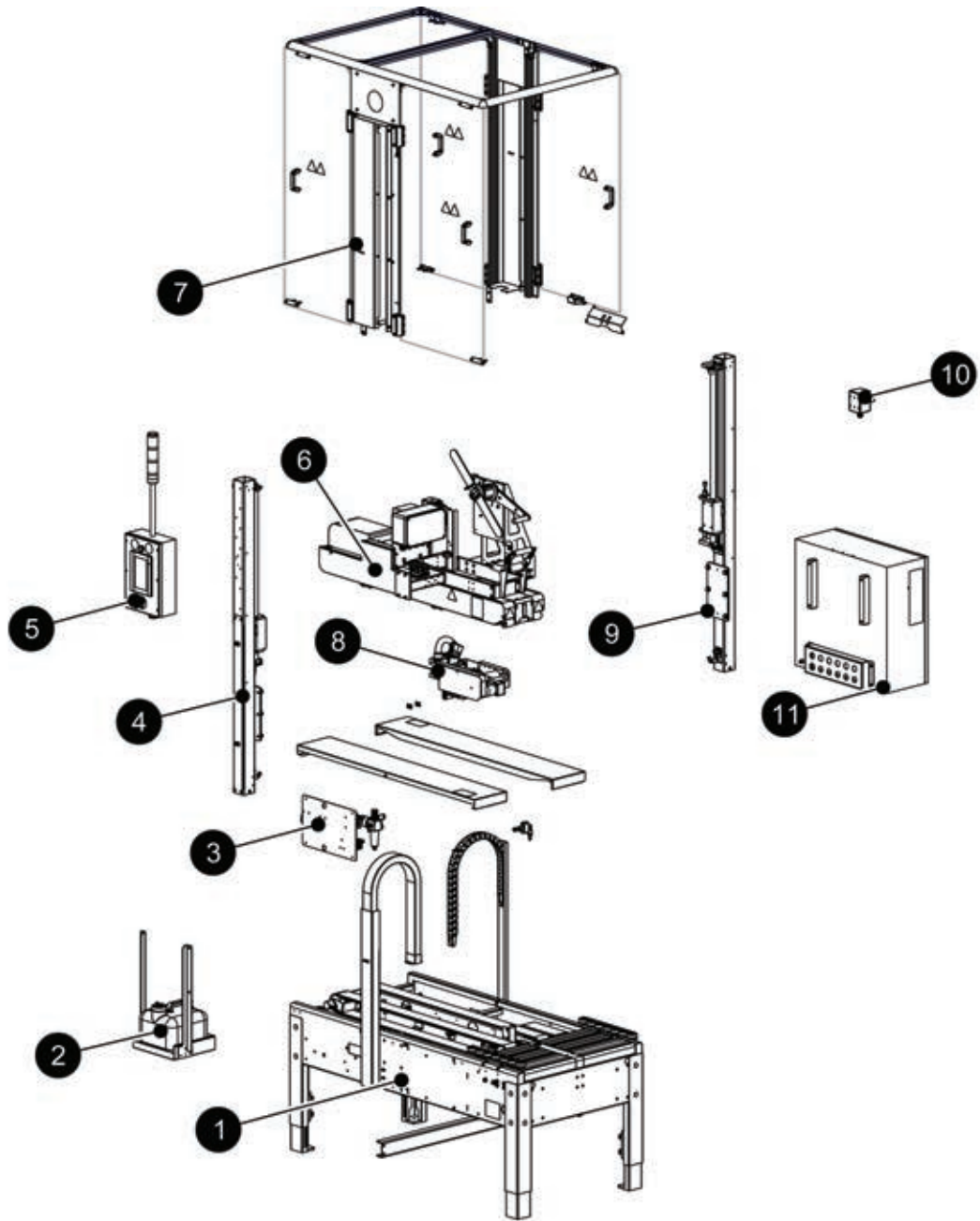
The top right of each page with a parts breakdown will show a red highlighted section of the machine that is being broken out into more detail.



Not all assemblies are sold as assemblies please consult IPG Machine Support for details.

# APPENDIX B

## Main Machine



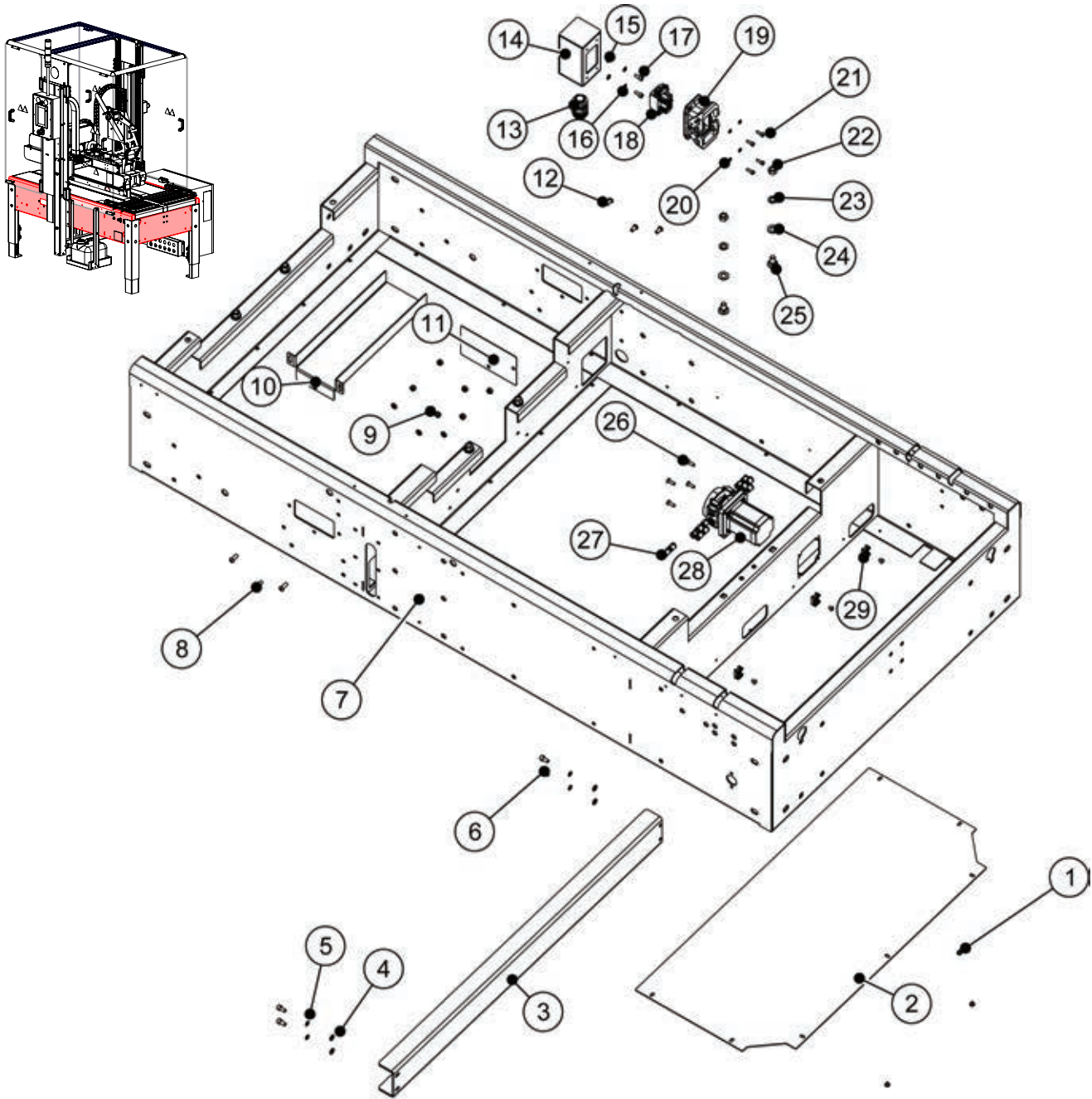
ITEM	DESCRIPTION
1	BASE ASSEM TO
2	WATER TANK SHELF ASSEM
3	MAIN PNEUMATIC ASSEM
4	LEFT COLUMN ASSEM

ITEM	DESCRIPTION
5	E-STOP - DOUBLE SWITCH
6	BRIDGE ASSEM
7	GUARDING
8	TOP WAT TAPEHEAD TB

ITEM	DESCRIPTION
9	RIGHT COLUMN ASSEM
10	E-STOP BOX
11	ELECTRICAL ASSEM

# APPENDIX B

## Base Frame

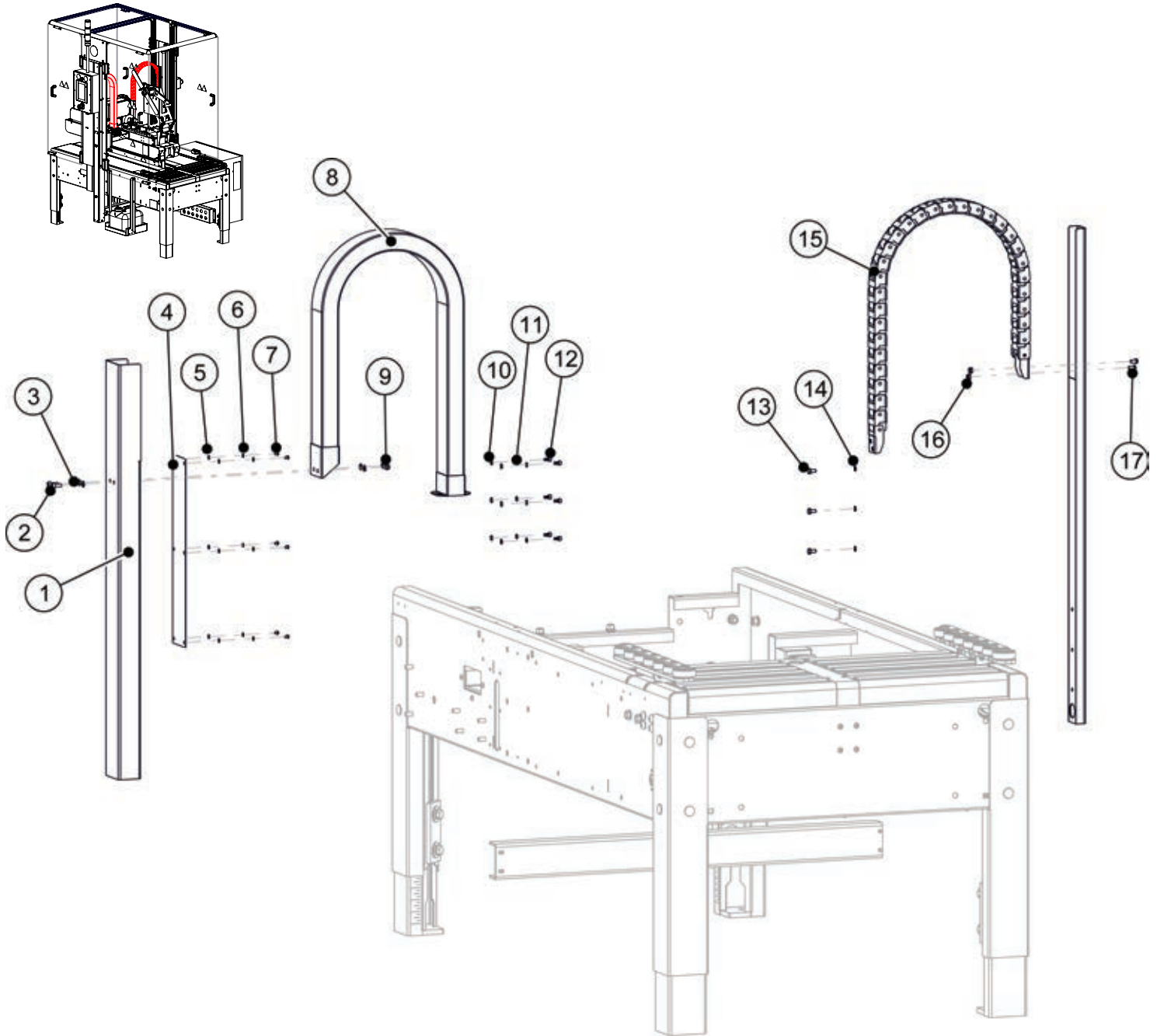


ITEM	PART NUMBER	DESCRIPTION	QTY
1	UF0038	BHCS M5-0.8 x 6mm	11
2	UPM6477	BASE BOTTOM COVER	1
3	UPM6414	COLLUMN SUPPORT CROSSBAR	1
4	UF1828	FW M6	7
5	UF6363	LW M6	4
6	UF3183	SHCS M6-1 x 12mm	4
7	UPM6469	BASE FRAME WELDMENT	1
8	UF6414	BHCS M6-1 x 16mm	3
9	UF5900	LOCK NUT M6-1.0	6
10	UPM6918	TAPE TROUGH	1
11	UPM6917	TAPE HOLE FILLER PLATE	1
12	UF1195	BHCS M6-1 x 12 mm	3
13	UPM5873	CABLE GLANDS	1
14	UPM6897	CONNECTOR BOX	1
15	UF3640	FW M5	2

ITEM	PART NUMBER	DESCRIPTION	QTY
16	UF7023	LW M5	2
17	UF7003	SHCS M5-0.8 x 12mm	2
18	UPM6885	10 POS HEAVY DUTY SOCKET	1
19	UPM6886	10 POS HEAVY DUTY MOUNT BASE	1
20	UF3681	LW M4	4
21	UF3801	SHCS M4-0.7 x 12mm	4
22	UF1540	HNR 3/8-16	6
23	UF6371	LW M10	6
24	UF3680	FW M10	6
25	UF4008	CARRIAGE BOLT HK 3/8-16 X 3/4	6
26	UF3277	FHCS M5-0.8 x 16 mm	4
27	UPM8059	STRAIGHT FITTING 6mm X 6mm	8
28	UPM6889	2 CHANNEL PERISTALTIC PUMP	1
29	UPM8117	CABLE TIE MOUNT	4

# APPENDIX B

## Drag Chains

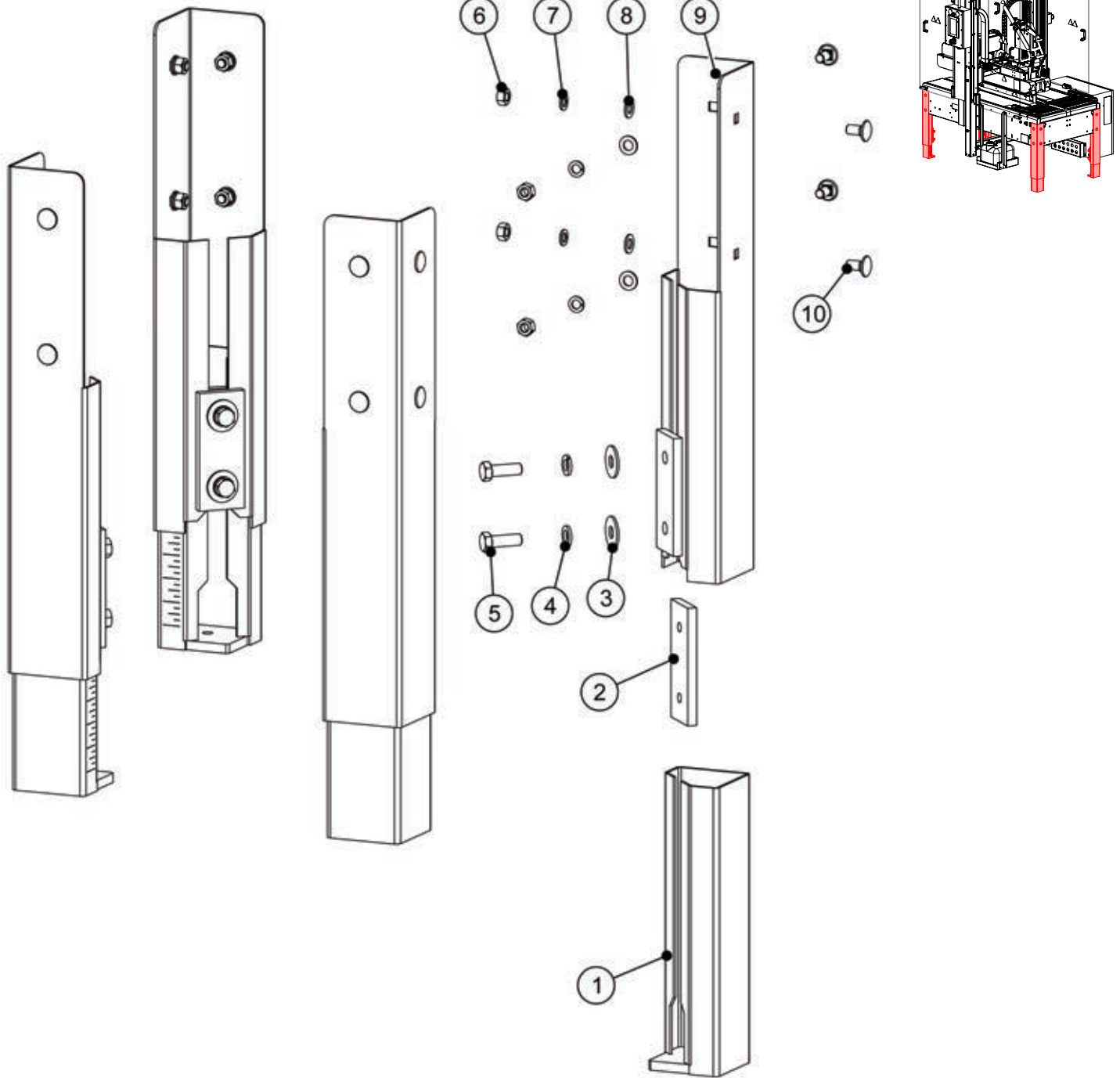


ITEM	PART NUMBER	DESCRIPTION	QTY
1	UPM6912	POWER E-CHAIN BASE MOUNT	1
2	UF0830	SHCS M6-1 x 16 mm	2
3	UF1828	FW M6	4
4	UPM4932	COVER PLATE	1
5	UF6339	FW M4	6
6	UF3749	LW M4	6
7	UF6374	BHCS M4-0.7 x 6mm	6
8	UPM4937	CABLE TRAY	1
9	UF3391	LOCK NUT M6-1.0	4

ITEM	PART NUMBER	DESCRIPTION	QTY
10	UF6340	FW M5	6
11	UF7023	LW M5	6
12	UF5201	SHCS M5-0.8 x 10mm	6
13	UF6313	HHCS M6-1.0 X 12mm	3
14	UF6363	LW M6	3
15	UPM6479	DRAG CHAIN	1
16	UPM6471	CABLE RAIL BRACKET	1
17	UF3278	BHCS M6-1 x 12 mm	2

# APPENDIX B

## Legs

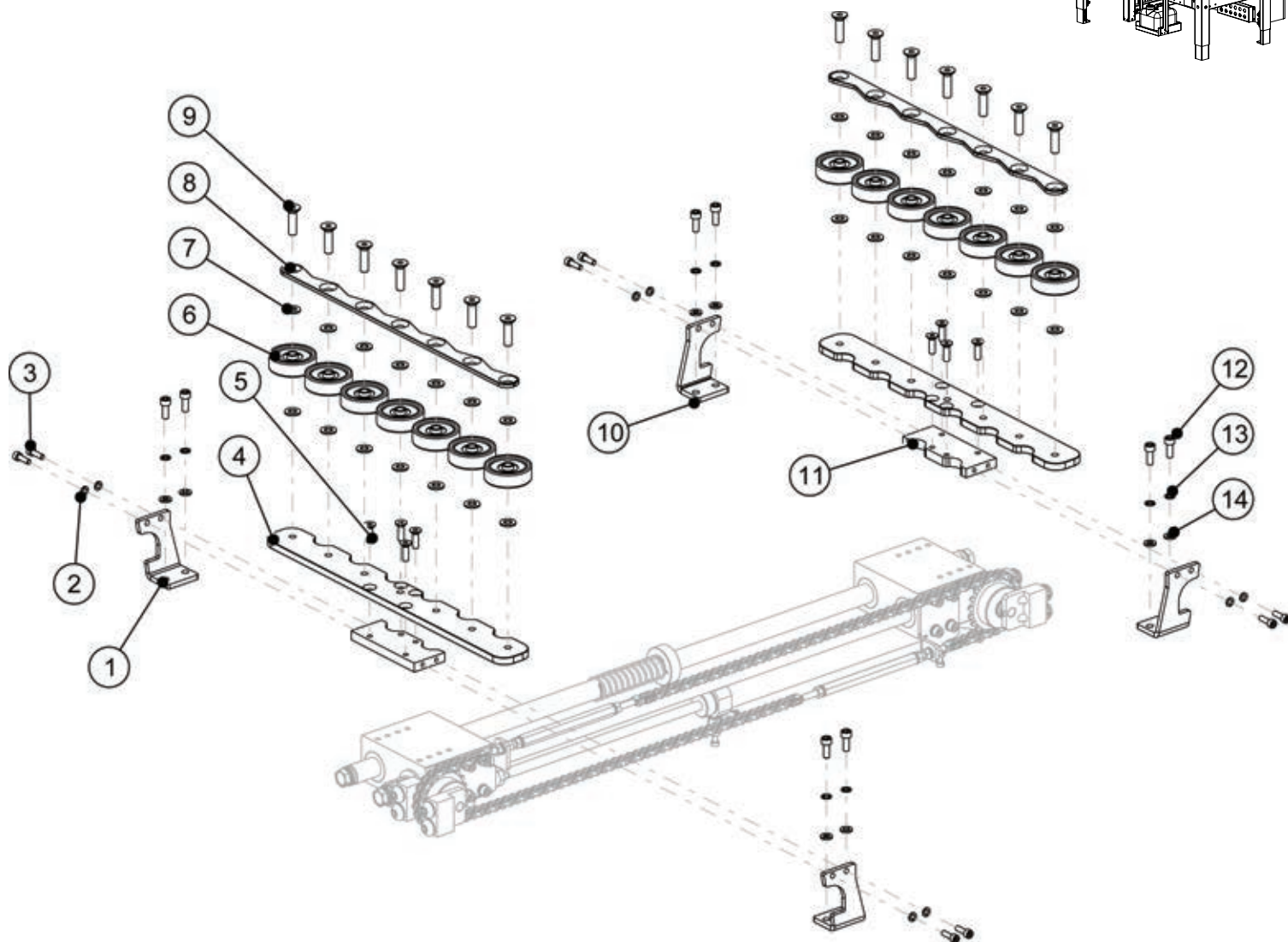
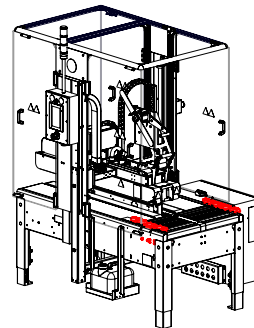


ITEM	PART NUMBER	DESCRIPTION	QTY
1	UPM7641	LEG EXTENSION	7
2	UPM7642	LEG FRICTION PLATE	4
3	UF4231	FW M12	8
4	UF4230	LW M12	8
5	UF6393	HHCS M12-1.75 x 35mm	8
6	UF6314	HNR M10 x 1.5	16

ITEM	PART NUMBER	DESCRIPTION	QTY
7	UF6371	LW M10	16
8	UF3680	FW M10	16
9	UPM7640	LEG WELDMENT	4
10	UF4229	CARRIAGE BOLT M10-1.5 x 20	16

# APPENDIX B

## Centering Assembly 1

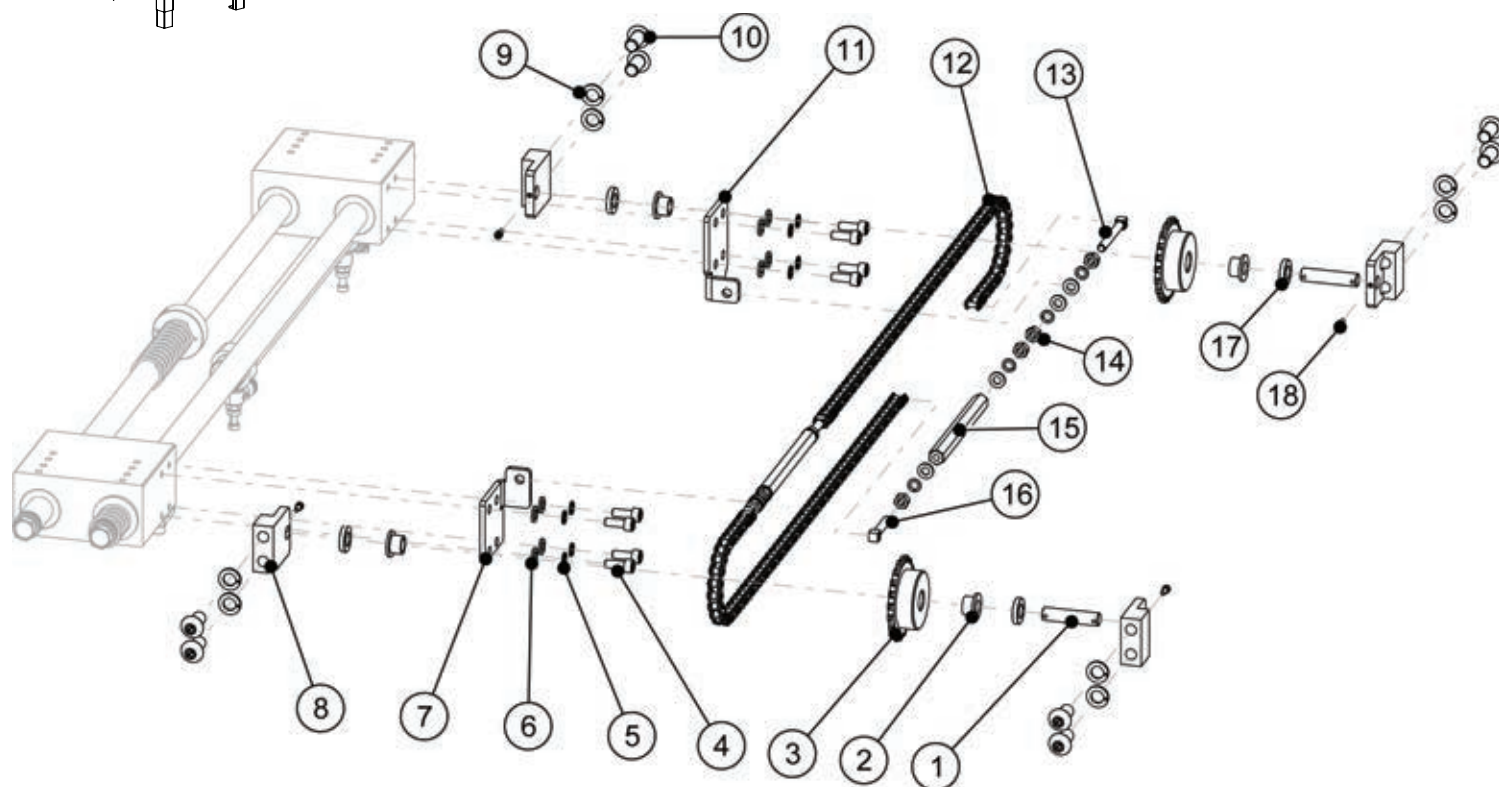
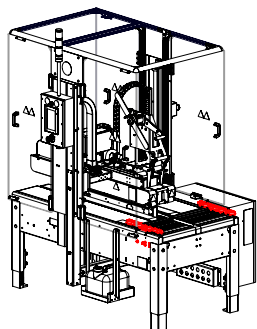


ITEM	PART NUMBER	DESCRIPTION	QTY
1	UPM6433	SPACER FOR ROLLER PLATE (RIGHT)	2
2	UF7023	LW M5	8
3	UF0191	SHCS M5-0.8 x 16mm	8
4	UPM6436	BOTTOM ROLLER PLATE	2
5	UF5402	FHCS M6-1 x 20mm	8
6	UPM6446	48MM ROLLER WHEEL	14
7	UF1821	FW M8	28
8	UPM6441	TOP ROLLER PLATE	2

ITEM	PART NUMBER	DESCRIPTION	QTY
9	UF6329	M8-1.25 X 30MM FHCS	14
10	UPM6432	SPACER FOR ROLLER PLATE (LEFT)	2
11	UPM6439	MOUNTING PLATE	2
12	UF3187	SHCS M6-1 x 16 mm	8
13	UF7023	LW M5	8
14	UF1828	FW M6	8

# APPENDIX B

## Centering Assembly 2

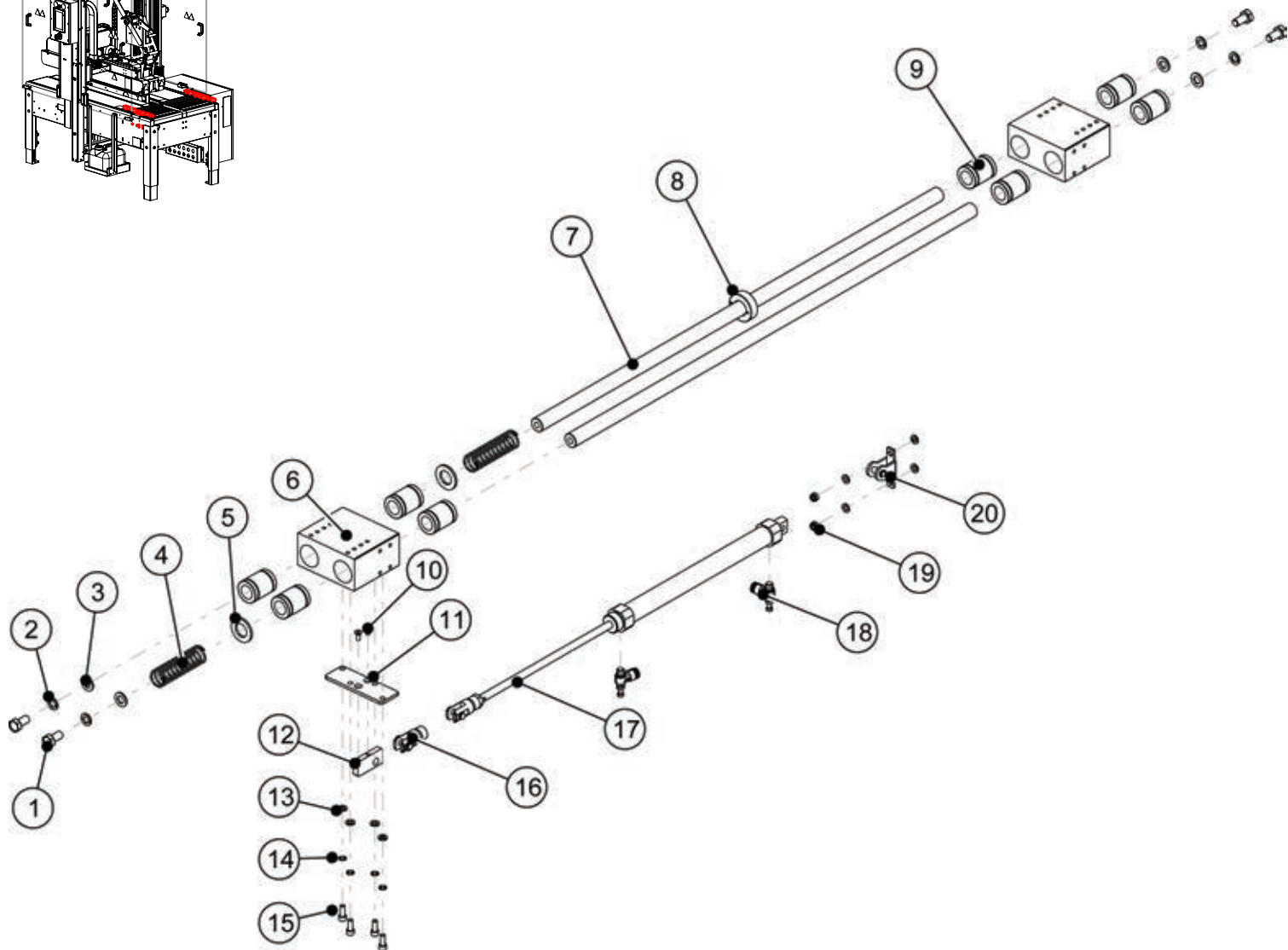
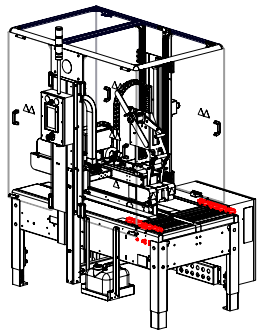


ITEM	PART NUMBER	DESCRIPTION	QTY
1	UPM6431	SPROCKET FIXED SHAFT	2
2	UPM1788EV	FLANGE BEARING BRONZE	4
3	UPM6444	SPROCKET #35	2
4	UF3187	SHCS M6-1 x 16 mm	8
5	UF6363	LW M6	16
6	UF1828	FW M6	16
7	UPM6437	TOP CHAIN ADAPTOR BRACKET	1
8	UPM6430	SPROCKET SUPPORT	4
9	UF6371	LW M10	8
10	UF4252	BHCS M10-1.5 x 20mm	8

ITEM	PART NUMBER	DESCRIPTION	QTY
11	UPM6438	BTM CHAIN ADAPTOR BRACKET	1
12	UPM6445	CHAIN #35 619MM	2
13	UPM3260	CHAIN THREADED LINK RH	2
14	UF3637	HNR M6-1.0	8
15	UPM3255	TURNBUCKLE	2
16	UPM3259	CHAIN THREADED LINK LH	2
17	UPM6425	SPACER	4
18	UF6400	SHCS M3-0.5 x 8MM	4

# APPENDIX B

## Centering Assembly 3

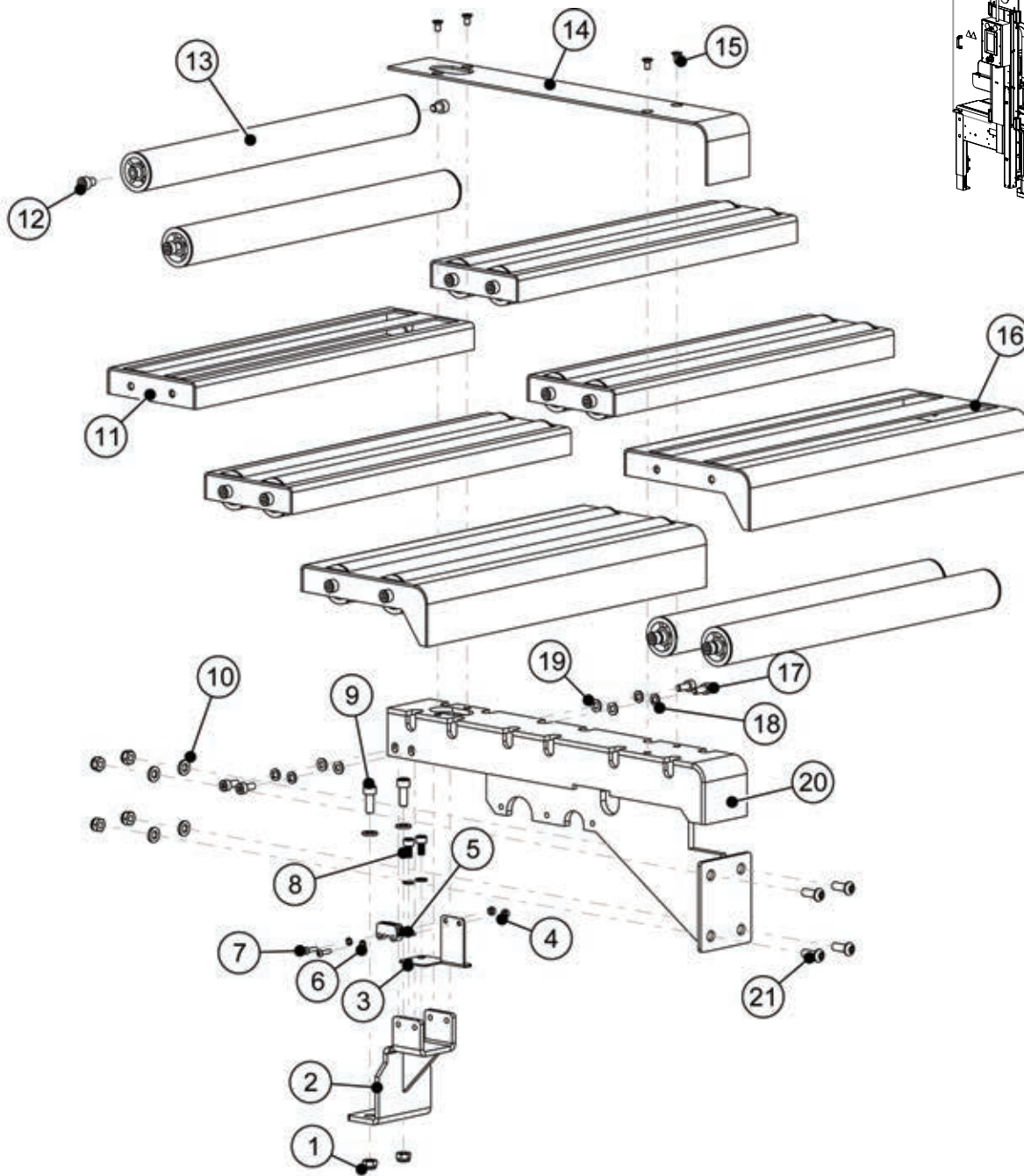


ITEM	PART NUMBER	DESCRIPTION	QTY
1	UF3679	HHCS M10-1.5 x 20mm	4
2	UF6371	LW M10	4
3	UF3680	FW M10	4
4	UPM6443	SPRING FOR 20MM SHAFT	2
5	UPM6442	ANTI-COLLISION GASKET	2
6	UPM6434	CROSS SHAFT BLOCK	2
7	UPM6450	20MM LINEAR SHAFT	2
8	UF9150	20MM SPLIT COLLAR SHAFT	1
9	UPM6449	20MM LINEAR BEARING	8
10	UF5400	FHCS M5-0.8 x 12mm	2
11	UPM6440	LINK PLATE #1	1

ITEM	PART NUMBER	DESCRIPTION	QTY
12	UPM6435	LINK PLATE #2	1
13	UF1828	FW M6	8
14	UF6363	LW M6	4
15	UF3187	SHCS M6-1 x 16mm	4
16	UPM6451	CYLINDER UPPER MOUNT	1
17	UPM6448	AIR CYLINDER	1
18	UPM6447	SPEED CONTROL JOINT	2
19	UF5900	NYLON LOCK NUT M6-1.0	2
20	UPM8106	CLEVIS PIVOT BRKT	1

# APPENDIX B

## Roller Table

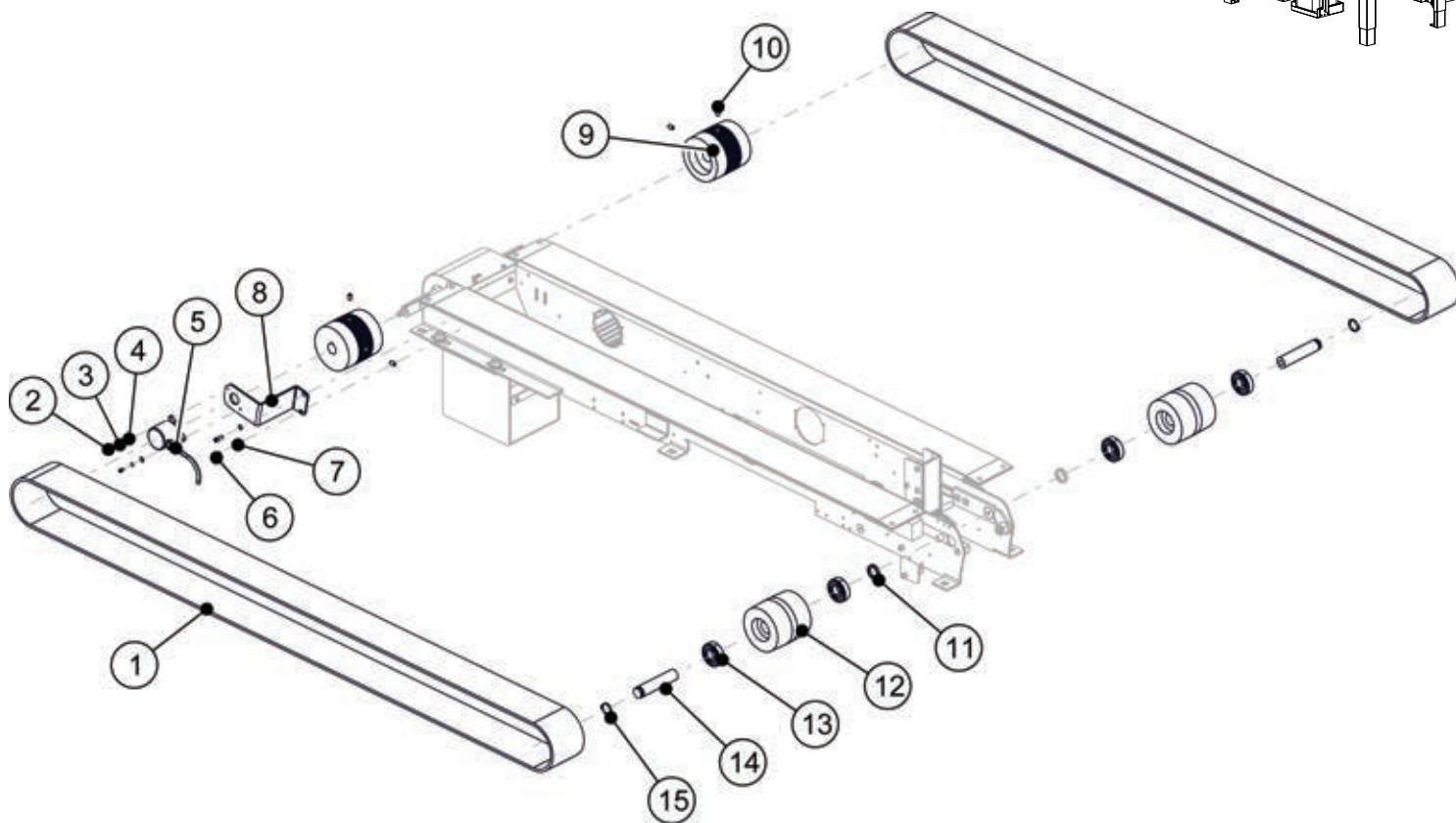
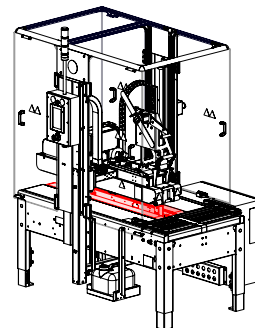


ITEM	PART NUMBER	DESCRIPTION	QTY
1	UF3391	LOCK NUT M6-1.0	6
2	UPM6475	ROLLER COVER SUPPORT SEAT	1
3	UPM6908	PHOTOEYE BRACKET	1
4	UF4112	HEX NUT M3-0.5	2
5	UPM7452	PHOTOEYE 30mm - M8	1
6	UF3718	LW M3	2
7	UF9164	BHCS M3-0.5 x 12mm	2
8	UF5201	SHCS M5-0.8 x 10mm	2
9	UF3187	SHCS M6-1 x 16mm	2
10	UF1828	FW M6	6
11	UPM6540	REAR ROLLER COVER	4

ITEM	PART NUMBER	DESCRIPTION	QTY
12	UF0810	SHCS M6-1 x 8mm	24
13	UPM6530	RSA-TB ROLLER	12
14	UPM6474	CENTER SUPPORT	1
15	UF3274	FHCS M4-0.7 x 8 mm	4
16	UPM6550	ROLLER FRONT COVER	2
17	UF7003	SHCS M5-0.8 x 1 2mm	4
18	UF7023	LW M5	6
19	UF6340	FW M5	4
20	UPM6473	CENTERING SUPPORT SEAT	1
21	UF6414	BHCS M6-1 x 16mm	4

# APPENDIX B

## Bottom Drive Belts

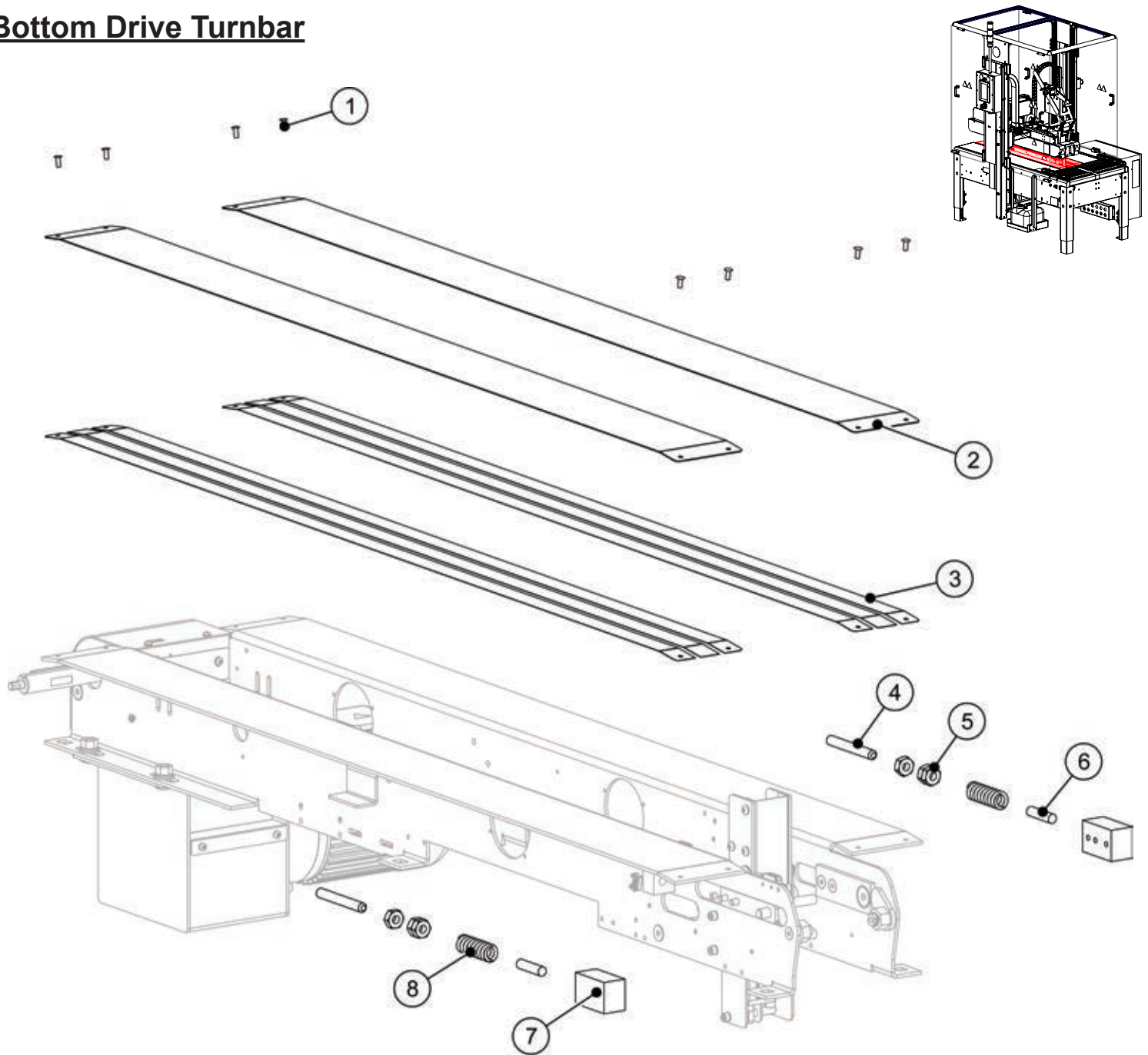


ITEM	PART NUMBER	DESCRIPTION	QTY
1	UPM6887	BELT 75mm X 2602mm	2
2	UF5202	SHCS M3-0.5 x 6mm	2
3	UF3718	M3 L.W.	2
4	UF3707	FW 3MM	2
5	UPM8145	ENCODER	1
6	UF3072	SHCS M4-0.7 x 8mm	2
7	UF3072	SHCS M4-0.7 x 8mm	2
8	UPM6927	ENCODER MOUNT	1

ITEM	PART NUMBER	DESCRIPTION	QTY
9	UPM4069	DRIVE PULLEY	2
10	UF3689	SSS M6-1.0 x 10mm	4
11	UPM6941	LOWER IDLER PULLEY SPACER	2
12	UPM4070	IDLER PULLEY	2
13	UPM0324	BALL BEARING	4
14	UPM6940	LOWER IDLER SHAFT	2
15	UF2220EV	EXT RET'G RING 3/4" SHAFT	2

# APPENDIX B

## Bottom Drive Turnbar

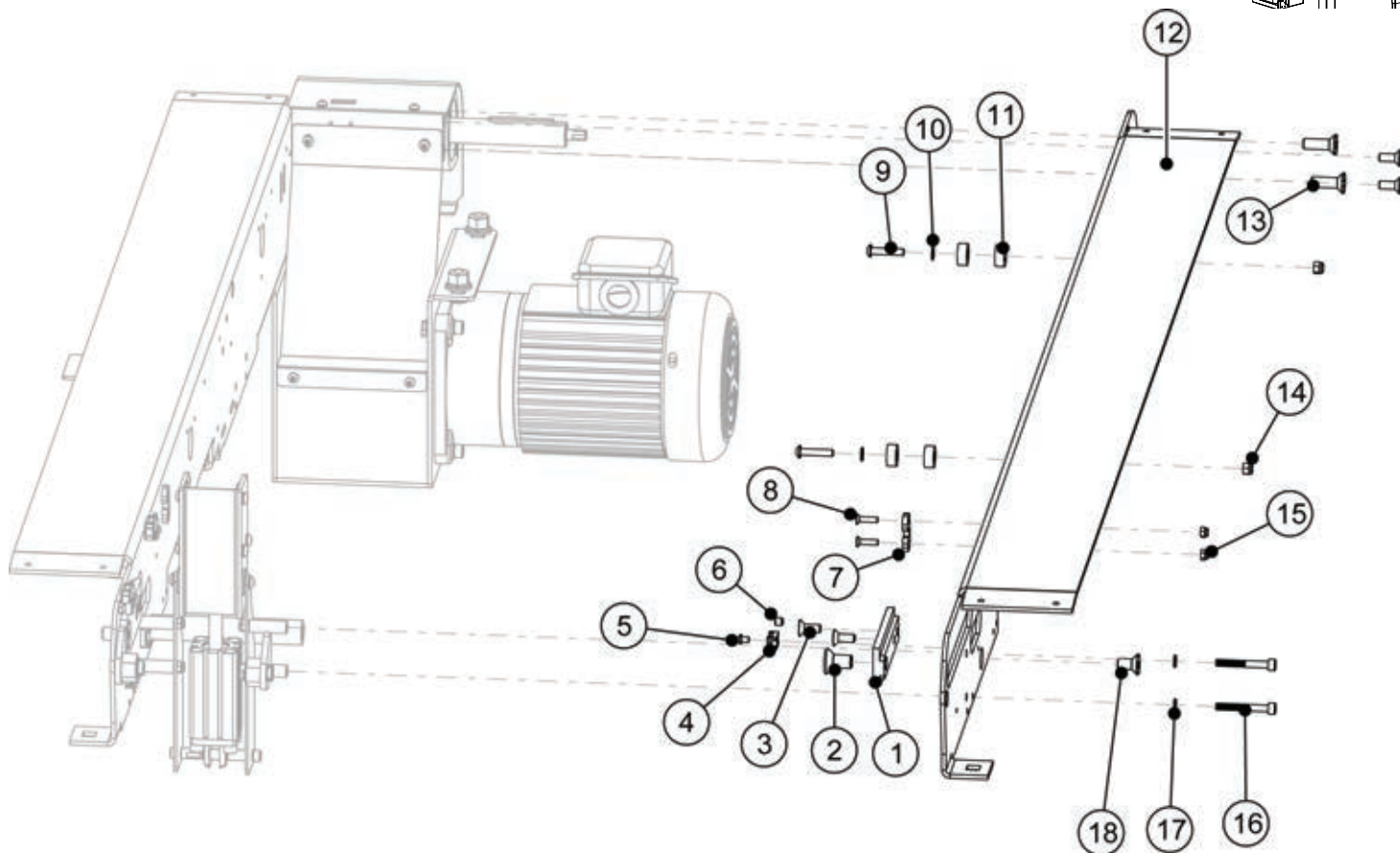
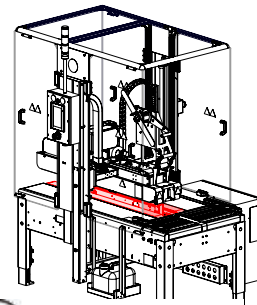


ITEM	PART NUMBER	DESCRIPTION	QTY
1	UF3691	POP RIVET 4mm	8
2	UPM6925	LOWER BELT GUIDE STRIP	2
3	UF6438	DOUBLE SIDED ADHESIVE	6
4	UF1400	TENSIONER ROD	2
5	UF1610	3/8"-16-HNR	6

ITEM	PART NUMBER	DESCRIPTION	QTY
6	UPM0112	SPRING LOCATOR PIN	2
7	UPM1234	COMPRESSION BLOCK	2
8	UPM0038	DIE SPRING	2

# APPENDIX B

## Bottom Drive Right Frame

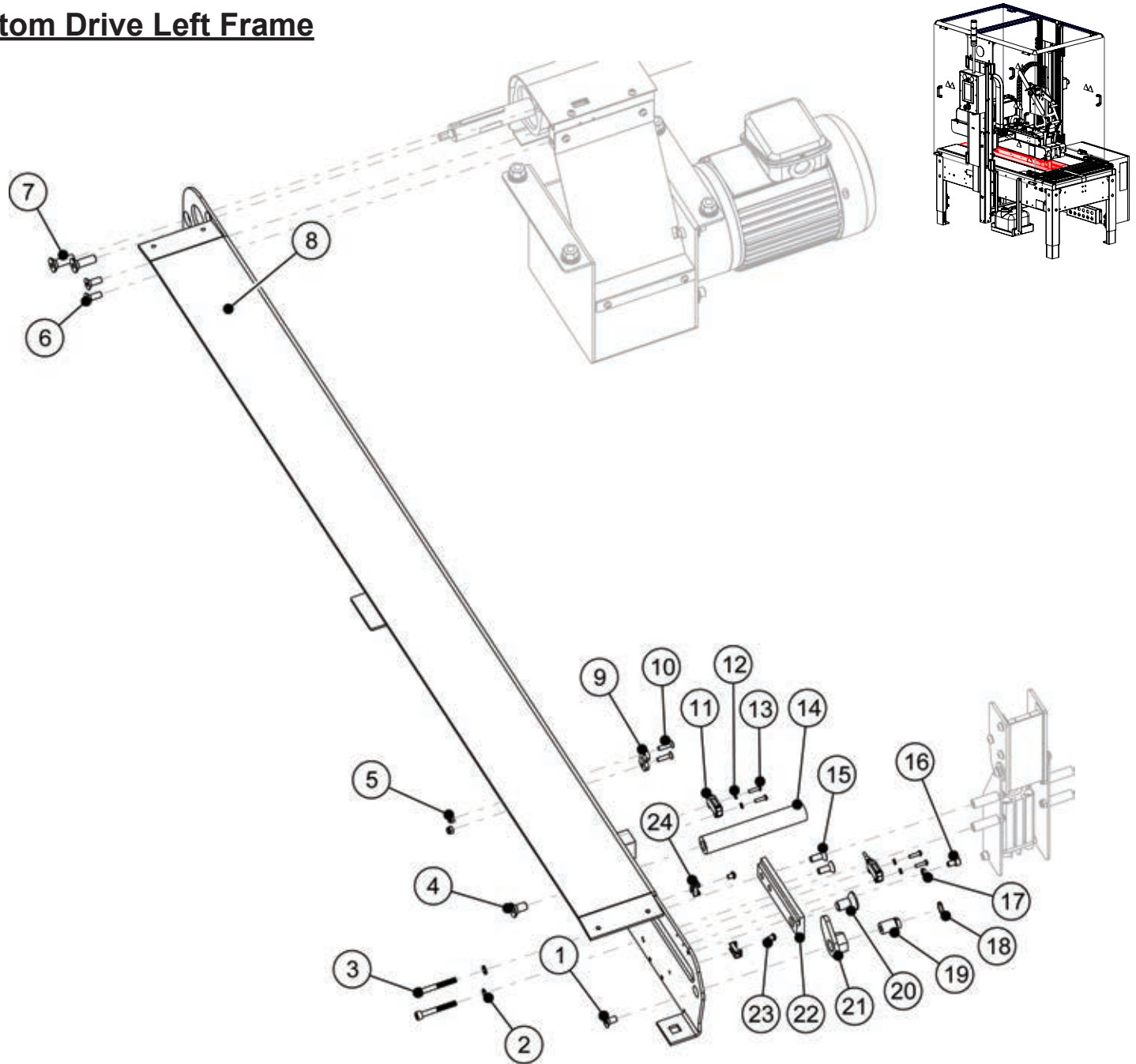


ITEM	PART NUMBER	DESCRIPTION	QTY
1	UPM2156	TENSIONNER SLIDE	1
2	UF3748	FHCS M10-1.5 x 20mm	1
3	UF1192	FHCS M6-1 x 16 mm	4
4	UPM6808	CABLE TIE MOUNT	1
5	UF7008	BHCS M4-0.7 x 6mm	1
6	UF6366	SSS M6-1.0 x 6mm	1
7	WET0255	TAPE CHUTE DETENT	1
8	UF4500	FHCS M4-0.7 x 16mm	2
9	UF3279	BHCS M5-0.8 x 12mm	2
10	UF6340	FW M5	2

ITEM	PART NUMBER	DESCRIPTION	QTY
11	UPH4613	KNIFE ARM BUMPER 6"TH	4
12	UPM6943	RH BTM DRIVE SECTION WELDMENT	1
13	UF6370	FHCS M8-1.25 x 25mm	2
14	UF3394	M5 LOCK NUT	2
15	UF6376	M4 LOCKNUT	2
16	UF3776	SHCS M5-0.8 x 35mm	2
17	UF7023	LW M5	2
18	UF3684	FHCS M8-1.25 x 16mm	1

# APPENDIX B

## Bottom Drive Left Frame

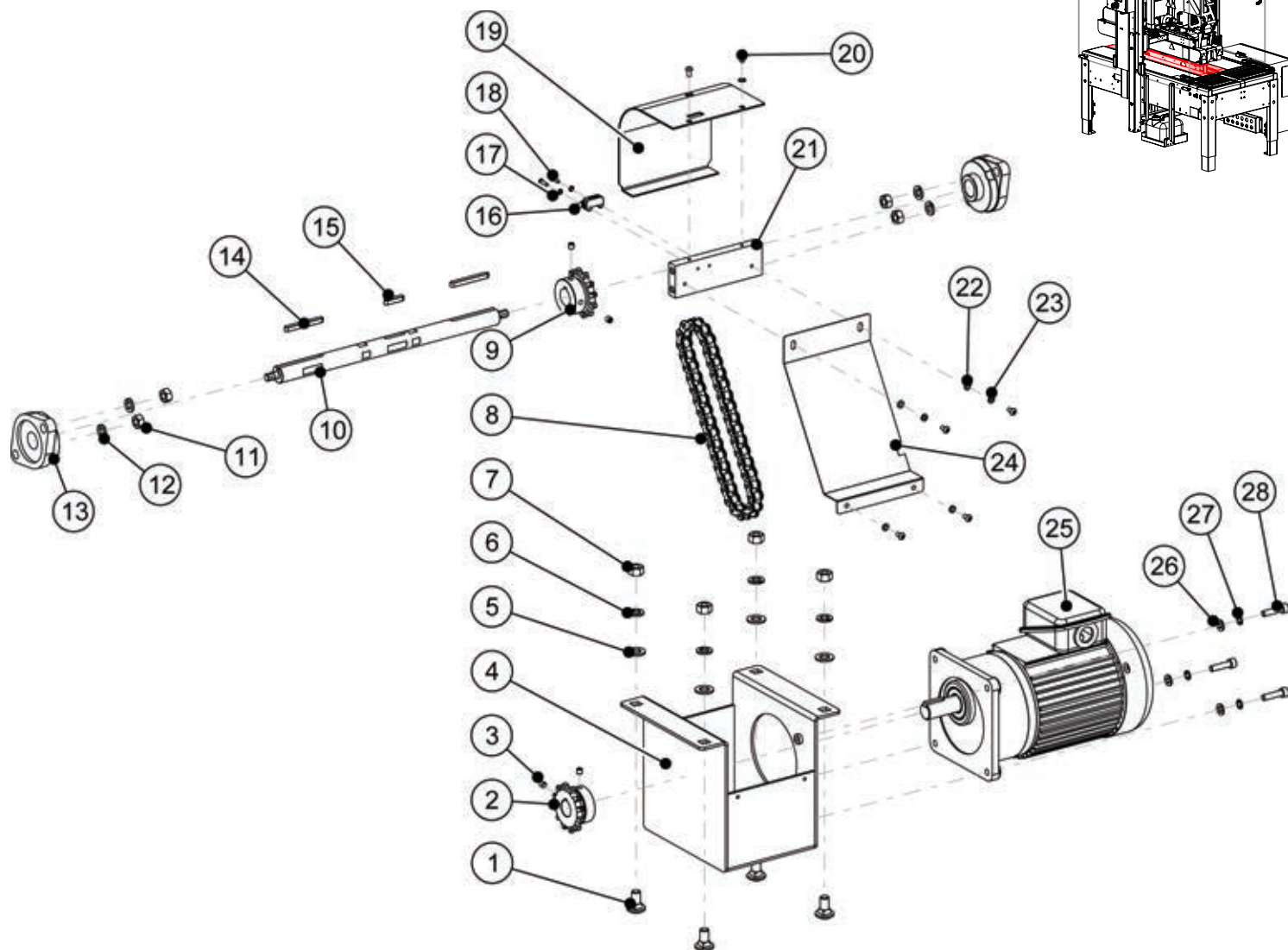


ITEM	PART NUMBER	DESCRIPTION	QTY
1	UF1042	FHCS M6-1 x 12mm	1
2	UF7023	LW M5	2
3	UF3776	SHCS M5-0.8 x 40mm	2
4	UF3684	FHCS M8-1.25 x 16mm	1
5	UF6376	NYLON LOCKNUT M4	2
6	UF1192	FHCS M6-1 x 16mm	2
7	UF1190	FHCS M8-1.25 x 20mm	2
8	UPM6942	LOWER LEFT DRIVE FRAME	1
9	WET0255	TAPE CHUTE DETENT	1
10	UF4500	FHCS M4-0.7 x 16mm	2
11	UPM7452	MINI PHOTOEYE 30mm	2
12	UF3718	LW M3	4
13	UF9164	BHCS M3-0.5 x 12mm	4

ITEM	PART NUMBER	DESCRIPTION	QTY
14	UPM6391	SPACER .75" DIA	1
15	UF1192	FHCS M6-1 x 16 mm	2
16	UF7003	SHCS M5-0.8 x 12mm	1
17	UF7007	Hex Nut M5	1
18	UF3558	RETAINING RING	1
19	UPM6316	ADJUSTER MANDREL	1
20	UF3748	FHCS M10-1.5 x 20mm	1
21	UPM6314	BELT TENSIONER LH	1
22	UPM2156	TENSIONNER SLIDE	1
23	UF7008	BHCS M4-0.7 x 6mm	2
24	UPM6808	CABLE TIE MOUNT	2

# APPENDIX B

## Bottom Drive Motor

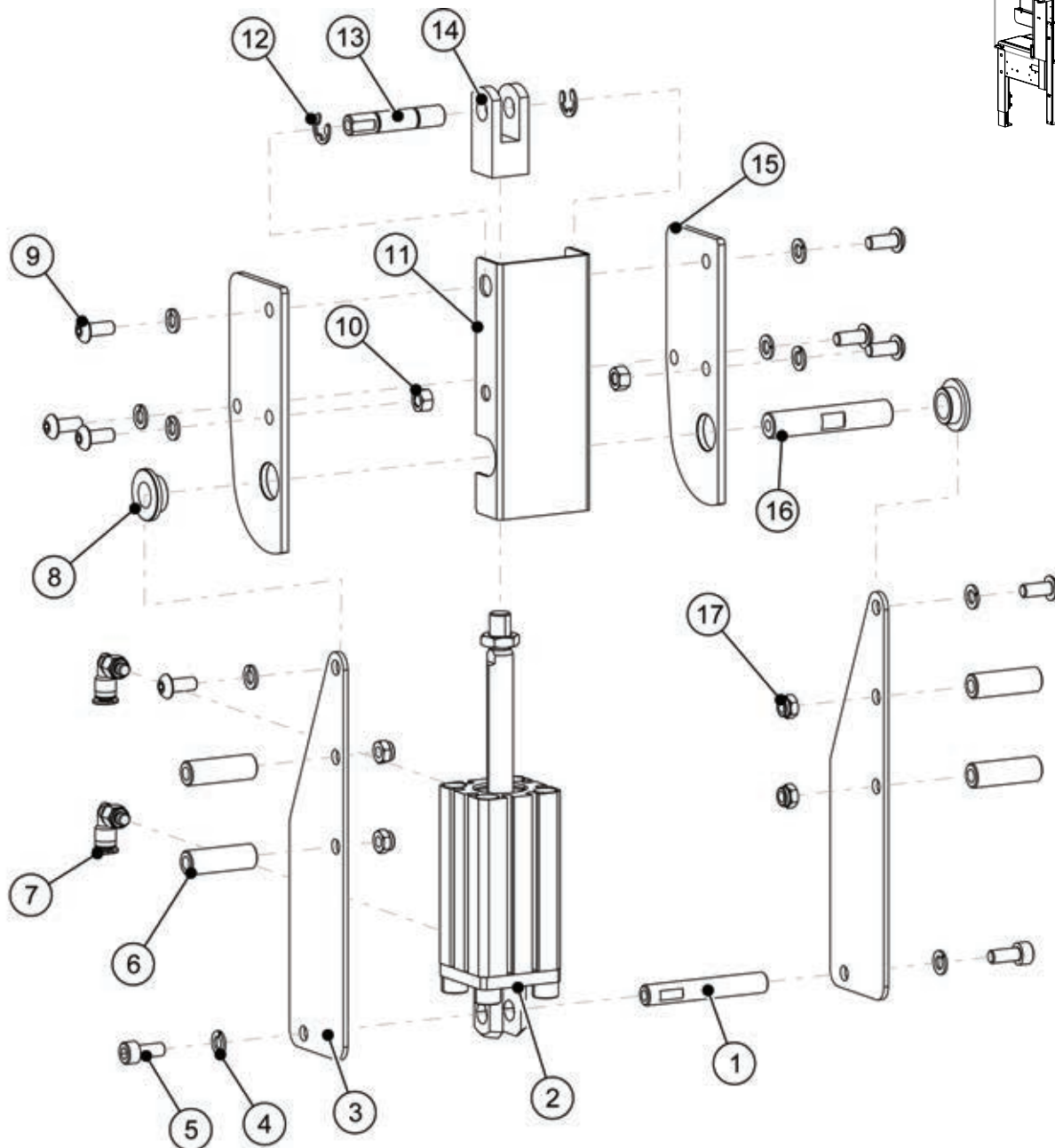
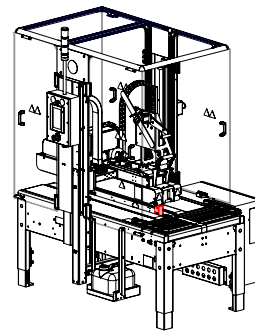


ITEM	PART NUMBER	DESCRIPTION	QTY
1	UF4008	CARRIAGE BOLT 3/8-16 x 3/4	4
2	UPM6396	SPROCKET #40 12T	1
3	UF1411	SSS M6 x 6mm	4
4	UPM6938	LOWER DRIVE MOTOR MOUNT	1
5	UF3680	FW M10	4
6	UF6371	LW M10	4
7	UF1540	HNR 3/8-16	4
8	UPM6397	CHAIN #40	1
9	UPM6395	SPROCKET #40 12T	1
10	UPM6939	LOWER DRIVE SHAFT	1
11	UF0866	HNR M8 - 1.25	4
12	UF0867	LW M8	4
13	UPM0069	FLANGE BEARING 3/4" ID	2
14	UF0194	SQUARE KEY ROUND ENDS 5x5x50	2
15	UF0194	SQUARE KEY ROUND ENDS 5x5x25	1

ITEM	PART NUMBER	DESCRIPTION	QTY
16	UPM7452	PHOTOEYE	1
17	UF3718	LW M3	2
18	UF9164	BHCS M3-0.5 x 12mm	2
19	UPM6936	LOWER DRIVE CHAIN GUARD	1
20	UF3685	BHCS M4-0.7 x 8mm	6
21	UPM6937	LOWER DRIVE CHAIN GUARD MOUNT	1
22	UF6339	FW M4	2
23	UF3749	LW M4	6
24	UPM6388	FRONT CHAIN GUARD	1
25	UPM6789	1/3 HP 1:15 MOTOR	1
26	UF1828	FW M6	3
27	UF6411	LW M6	3
28	UF3180	SHCS M6-1 X 25mm	3

# APPENDIX B

## Gate

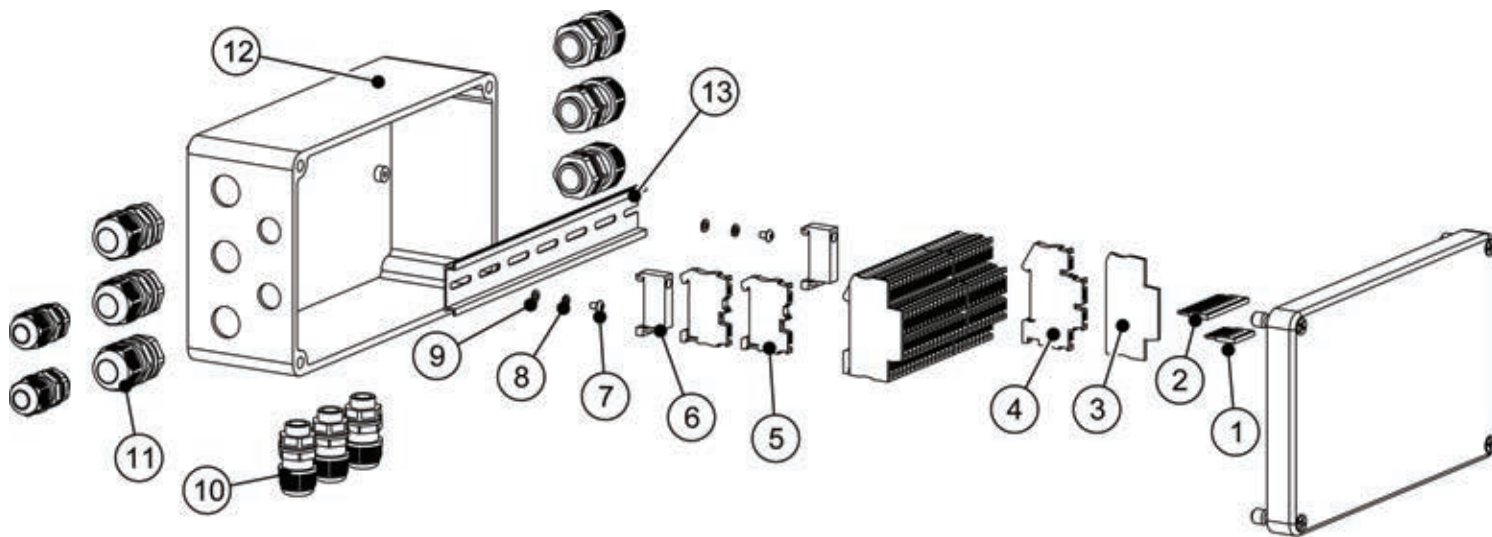
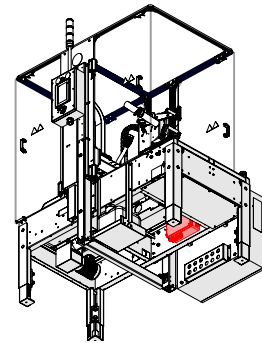


ITEM	PART NUMBER	DESCRIPTION	QTY
1	UPM6929	GATE CLEVIS SHAFT	1
2	UPM7375	CYLINDER 20 X 50	1
3	UPM6930	GATE MOUNT PLATE	2
4	UF7023	LW M5	10
5	UF9154	SHCS M5-0.8 x 12mm	2
6	UPM6933	GATE STANDOFF	4
7	UPH4905	M5 x 4mm ELBOW FITTING	2
8	WPT0004	OILITE FLANGE BEARING 10mm	2
9	UF3687	BHCS M5-0.8 X 12mm	8

ITEM	PART NUMBER	DESCRIPTION	QTY
10	UF6307	HEX NUT M5-0.8	2
11	UPM6932	GATE	1
12	UF3559	E-RING 8MM	2
13	UPM6934	GATE YOKE SHAFT	1
14	UPM7451	KNUCKLE JOINT M8	1
15	UPM6928	GATE PIVOT ARM	2
16	UPM6931	GATE PIVOT SHAFT	1
17	UF3394	SS NYLON LOCKNUT M5	4

# APPENDIX B

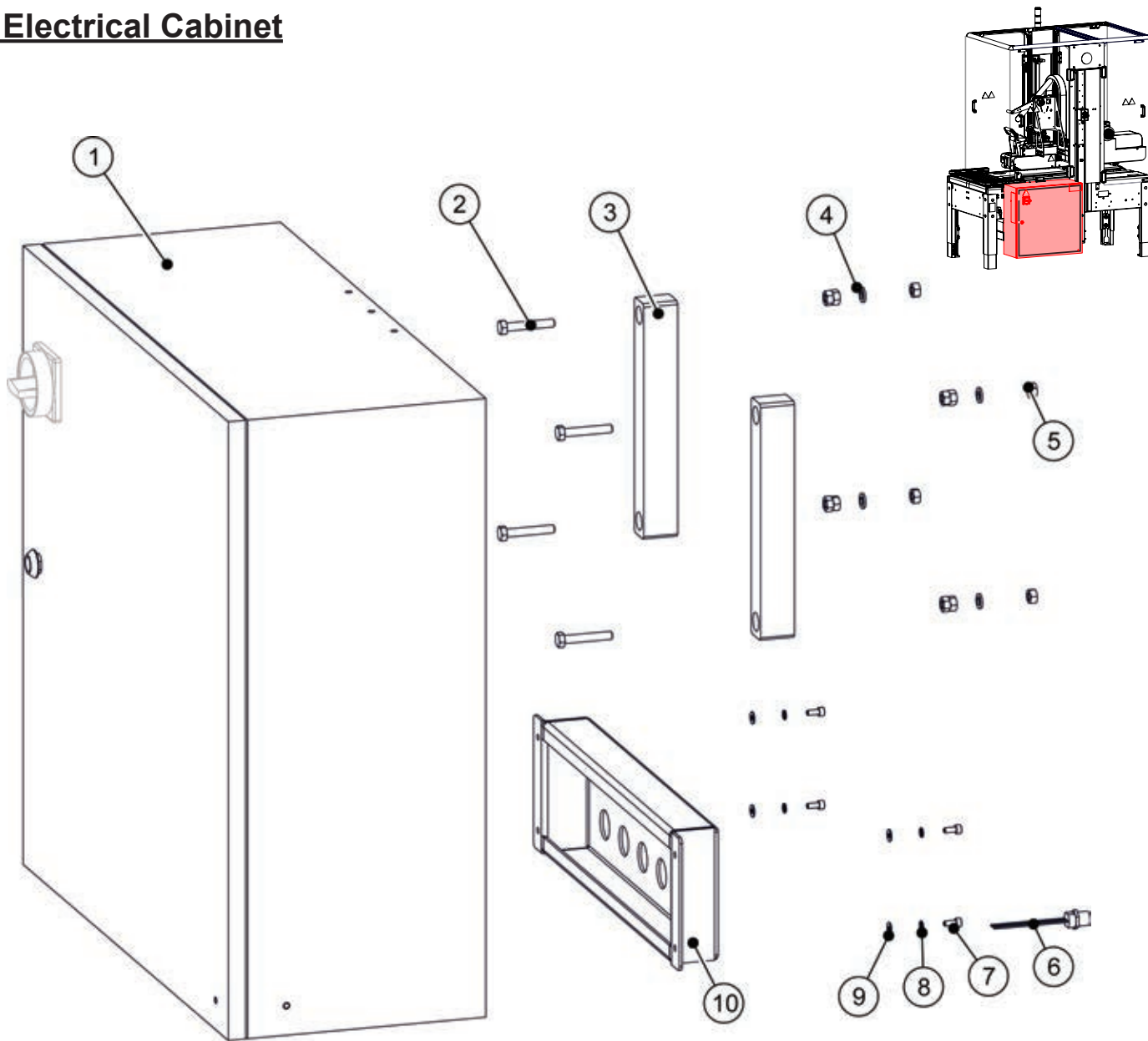
## Bottom Sub-Electrical Box



ITEM	PART NUMBER	DESCRIPTION	QTY
1	UPM6198	5 PIN BRIDGE	1
2	UPM6199	10 PIN BRIDGE	1
3	UPM6195	END COVER	3
4	UPM6193	DOUBLE LEVEL TERMINAL BLOCK	25
5	UPM6194	TERMINAL BLOCK, GROUND	2
6	UPM7440EV	DIN RAIL ANCHOR	2
7	UF6374	BHCS M4-0.7 x 6mm	2
8	UF3749	LW M4	2
9	UF3710	FW M4	2
10	UPM6178	CABLE GLAND	5
11	UPM5873	CABLE GLAND	6
12	UPM8061	ELECTRICAL BOX 150 X 250	1
13	UPM6904	ELEC BOX DIN RAIL	1

# APPENDIX B

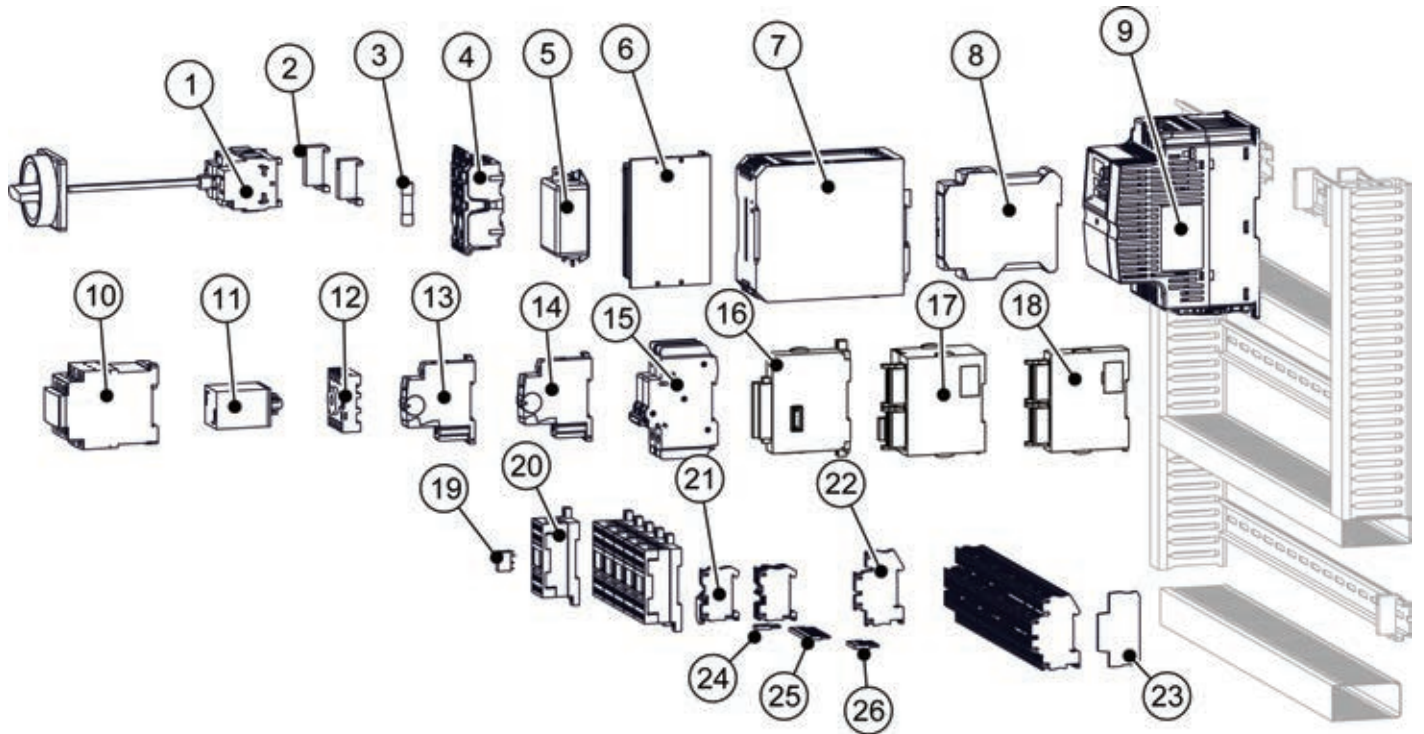
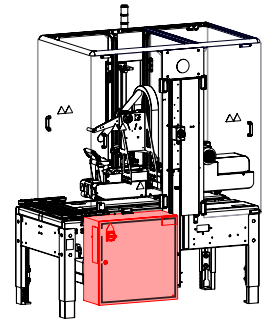
## Main Electrical Cabinet



ITEM	PART NUMBER	DESCRIPTION	QTY
1	UAM0651	ELECTRICAL ENCLOSURE	1
2	UF2900	HHCS HK M8 X 50	4
3	UPM6903	ENCLOSURE SPACER	2
4	UF0867	LW M8	4
5	UF0866	HNR M8 - 1.25	12
6	UPM8182	M12 BULKHEAD CONNECTOR 4-PIN	1
7	UF7003	SHCS M5-0.8 x 12mm	4
8	UF7021	LW M5	4
9	UF6340	FW M5	4
10	UPM6900	ENCLOSURE - EGRESS	1

# APPENDIX B

## Electrical Cabinet Components

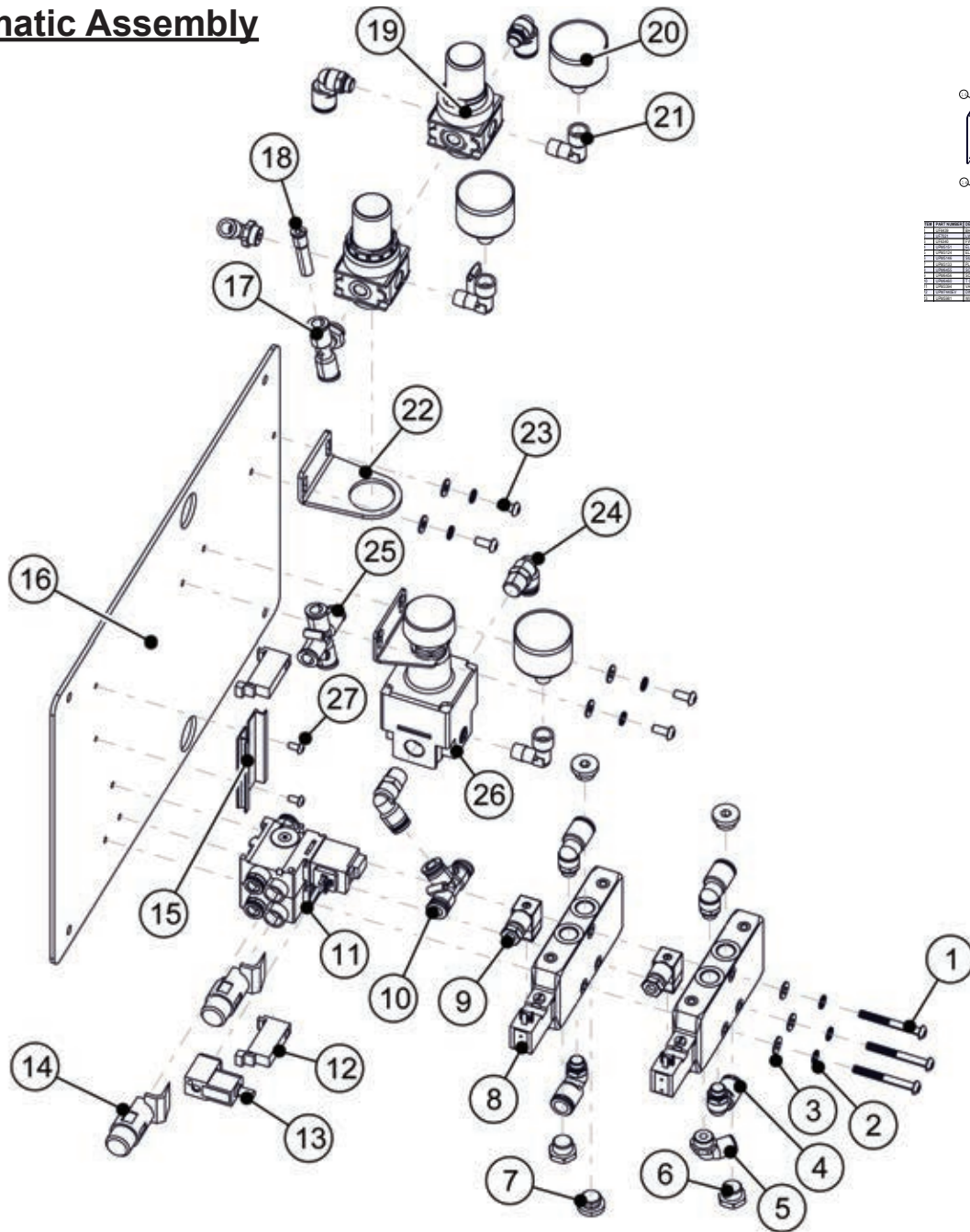


ITEM	PART NUMBER	DESCRIPTION	QTY
1	UPM6178	MAIN POWER SWITCH	1
2	UPM7440EV	DIN RAIL ANCHOR	6
3	UPM6513	FUSE TIME-DELAY 15A	2
4	UPM6511	CC FUSE BLOCK 2P	1
5	UPM6186	FILTER	1
6	UPM8060	STEPPER MOTOR DRIVER	1
7	UPM4912	POWER SUPPLY 240W	1
8	UPM6187	SAFETY MODULE	1
9	UPM6839	120V VFD	1
10	UPM6188	MOTOR STARTER 24VDC	1
11	UPM4459	RELAY 24V 11 PINS	1
12	UPM9726	RELAY SOCKET	1
13	UPM7635	LOOP PROTECTOR 7A	1
14	UPM7766	LOOP PROTECTOR 3A	1

ITEM	PART NUMBER	DESCRIPTION	QTY
15	UPM6510	2P, 8A CIRCUIT BREAKER	1
16	UPM8141	D TO A MODULE	1
17	UPM8139	PLC	1
18	UPM8140	FX5-C32ET/DSS-TS	1
19	UPM4915	PCB POWER RELAYS	24
20	UPM4922	RELAY OUTPUT TERMINAL BLOCK	6
21	UPM6194	TERMINAL BLOCK, GROUND	4
22	UPM6193	DOUBLE LEVEL TERMINAL BLOCK	50
23	UPM6195	END COVER	6
24	UPM6197	2 PIN BRIDGE	3
25	UPM6199	10 PIN BRIDGE	2
26	UPM6198	5 PIN BRIDGE	4

# APPENDIX B

## Main Pneumatic Assembly



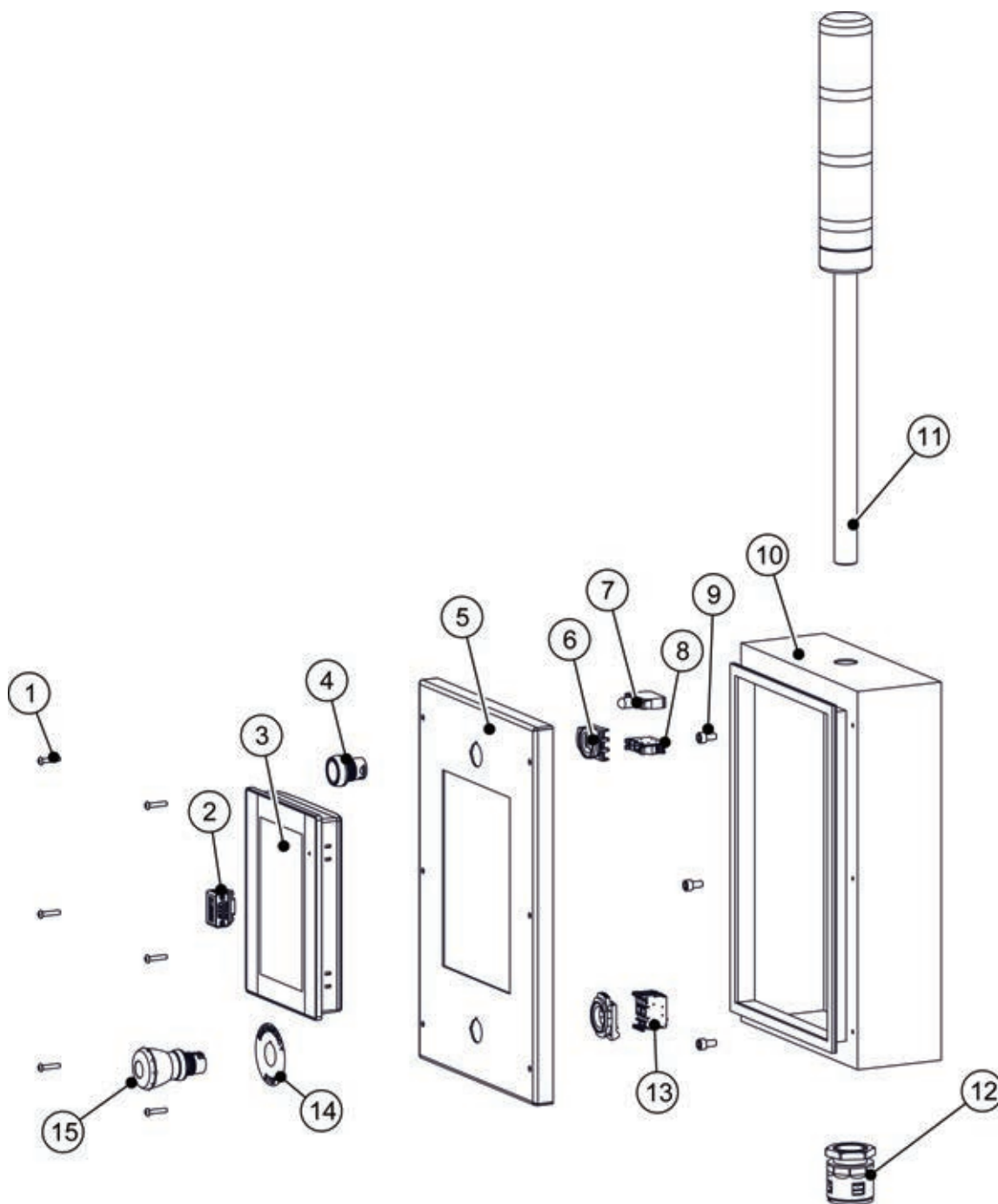
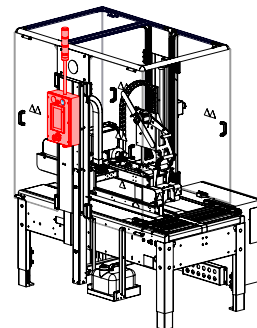
ITEM	PART NUMBER	DESCRIPTION	QTY
1	UF6439	BHCS M5-0.8 x 45mm	3
2	UF7021	LW M5	7
3	UF6340	FW M5	7
4	UPM5151	ELBOW FITTING, 10 ID	6
5	UPM3124	ELBOW FTG.SWVL G1/4	2
6	UPM5146	SILENCER	2
7	UPM3133	PLUG G1/4"	3
8	UPM6455	SOLENOID VALVE	2
9	UPM6456	SOLENOID CONNECTOR	2
10	UPM6460	T QUICK CONECTOR 8mm	1
11	UPM3394	VALVE 5/2 MAN. ADJUSTABLE 24V	1
12	UPM7440EV	DIN RAIL ANCHOR	2
13	UPM5981	WIRE CONNECTOR	1
14	UPM3391	SILENCER VALVE	2
15	UPM0407	DIN RAIL	1
16	UPM7158	MAIN PNEUMATICS PLATE	1
17	UPM8119	T UNION	1
18	UPM6872	STRAIGHT REDUCER	1
19	UPM3268	PRESSURE REGULATOR	2
20	UPM3273	PRESSURE GAUGE G1/8	3
21	UPM7736	BRASS ELBOW	3
22	UPM3271	MOUNTING BRACKET	1
23	UF3687	BHCS M5-0.8 x 12mm	4
24	UPM6467	90° QUICK CONNECTOR	2
25	UPM8120	8mm X-PLUG FITTING	1
26	UPM6457	PRECISION PRESSURE REGULATOR	1
27	UF3685	BHCS M4-0.7 x 8mm	2

ITEM	PART NUMBER	DESCRIPTION	QTY
1	UF6439	BHCS M5-0.8 x 45mm	3
2	UF7021	LW M5	7
3	UF6340	FW M5	7
4	UPM5151	ELBOW FITTING, 10 ID	6
5	UPM3124	ELBOW FTG.SWVL G1/4	2
6	UPM5146	SILENCER	2
7	UPM3133	PLUG G1/4"	3
8	UPM6455	SOLENOID VALVE	2
9	UPM6456	SOLENOID CONNECTOR	2
10	UPM6460	T QUICK CONECTOR 8mm	1
11	UPM3394	VALVE 5/2 MAN. ADJUSTABLE 24V	1
12	UPM7440EV	DIN RAIL ANCHOR	2
13	UPM5981	WIRE CONNECTOR	1
14	UPM3391	SILENCER VALVE	2

ITEM	PART NUMBER	DESCRIPTION	QTY
15	UPM0407	DIN RAIL	1
16	UPM7158	MAIN PNEUMATICS PLATE	1
17	UPM8119	T UNION	1
18	UPM6872	STRAIGHT REDUCER	1
19	UPM3268	PRESSURE REGULATOR	2
20	UPM3273	PRESSURE GAUGE G1/8	3
21	UPM7736	BRASS ELBOW	3
22	UPM3271	MOUNTING BRACKET	1
23	UF3687	BHCS M5-0.8 x 12mm	4
24	UPM6467	90° QUICK CONNECTOR	2
25	UPM8120	8mm X-PLUG FITTING	1
26	UPM6457	PRECISION PRESSURE REGULATOR	1
27	UF3685	BHCS M4-0.7 x 8mm	2

# APPENDIX B

## Operator Controls

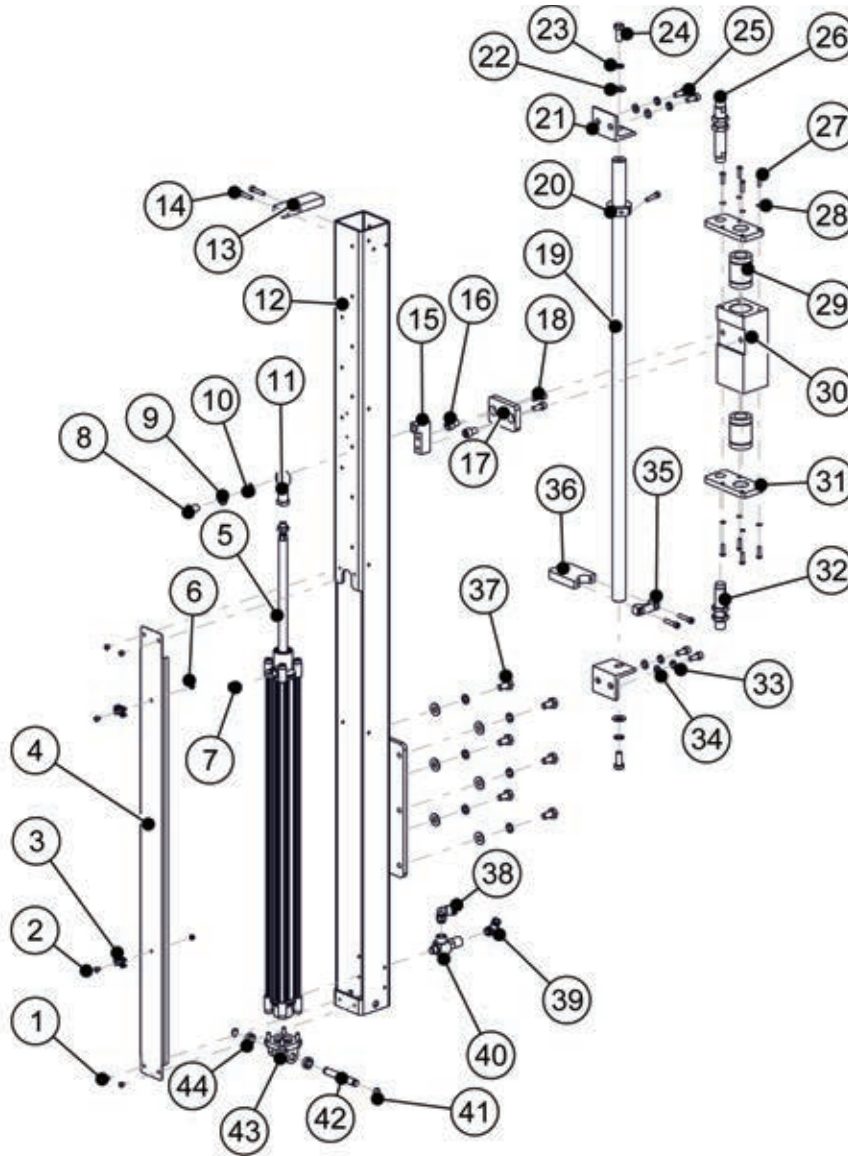
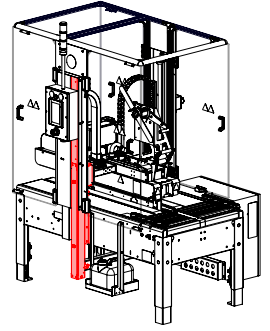


ITEM	PART NUMBER	DESCRIPTION	QTY
1	UF4325	BHCS M4-0.7 x 20mm	6
2	UPM6884	DB9 RIGHT ANGLE ADAPTER	1
3	UPM4906	HMI TOUCH PANEL	1
4	UPM6047	BUTTON, BLUE ILLUMINATED	1
5	UPM6948	CONTROL BOX COVER	1
6	UPM7630	LATCH	2
7	UPM8149	LAMP MODULE, LATCH MOUNT	1
8	UPM7631	NO CONTACT	1

ITEM	PART NUMBER	DESCRIPTION	QTY
9	UF0820	SHCS M6-1 x 12mm	3
10	UPM6947	CONTROL BOX	1
11	UPM5573	STATUS BAR	1
12	UPM4905	CORD GRIP	3
13	UPM4720	NC CONTACT	2
14	UPM6045	E-STOP LABEL	1
15	UPM3892	EMERGENCY STOP BUTTON	1

# APPENDIX B

## Left Column

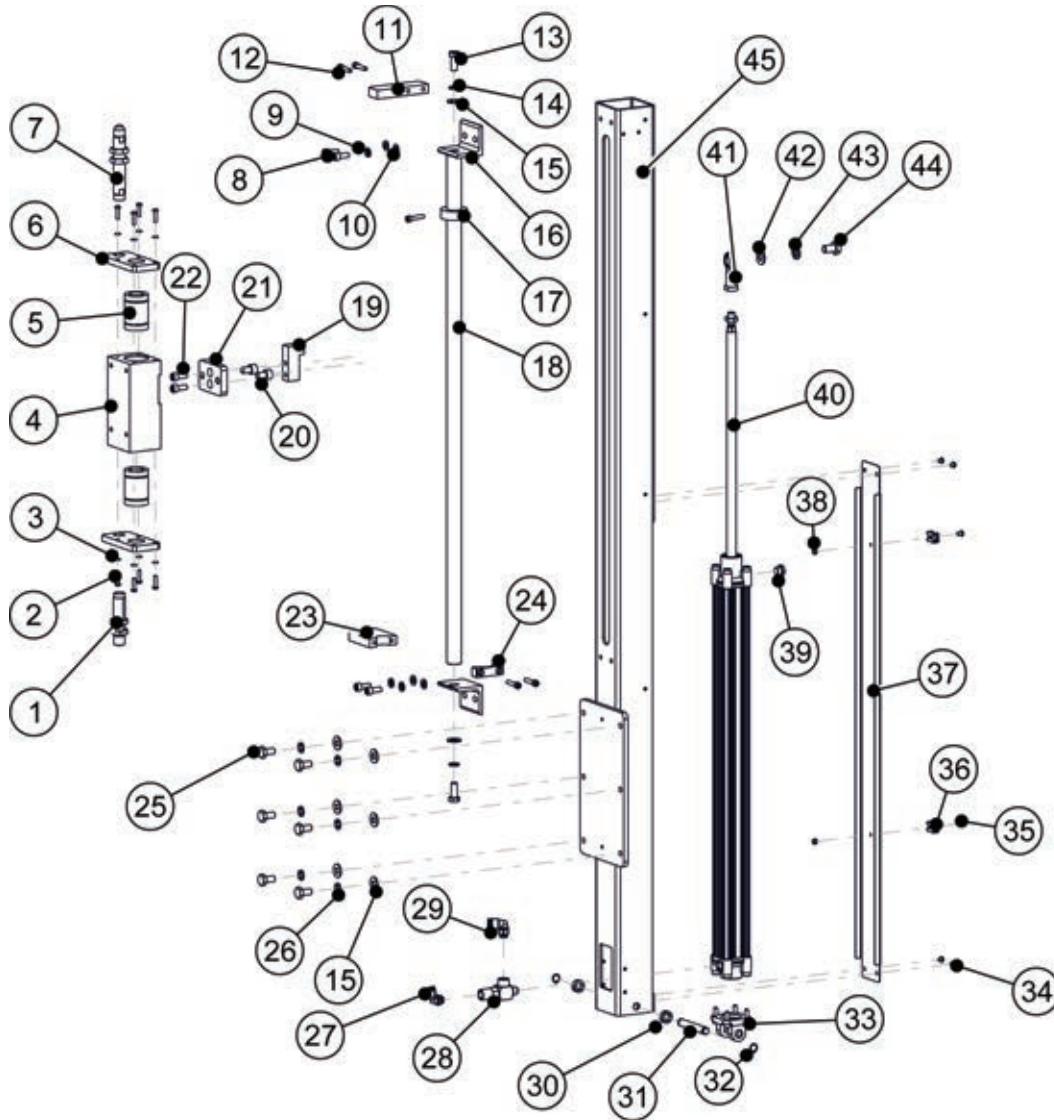


ITEM	PART NUMBER	DESCRIPTION	QTY
1	UF5601	BHCS M5 X 0.8 X 6mm	4
2	UF7010	BHCS M5-0.8 x 8 mm	2
3	UPM8117	CABLE TIE MOUNT	2
4	UPM6946	COLUMN COVER	1
5	UPM6421	AIR CYLINDER 600MM	1
6	UF3394	SS NYLON LOCKNUT M5	2
7	UPM5146	SILENCER	1
8	UF0061	HHCS M12-1.75 x 20mm	1
9	UF3733	LW M12	1
10	UF4231	FW M12	1
11	UPM6420	12MM ROD END BEARING	1
12	UPM6945	COLUMN	1
13	UPM6951	UPPER STOP BLOCK	1
14	UF4236	SHCS M6-1 X 30mm	5
15	UPM6413	LIFT CONNECTION BLOCK	1
16	UF3648	SHCS M10-1.5 x 16mm	2
17	UPM6417	SLIDER CONNECTING PLATE	1
18	UF3755	SHCS M8-1.25 x 20mm	2
19	UPM6419	LINEAR AXIS ROD	1
20	UPM1912	SHAFT COLLAR 25mm	1
21	UPM6415	MANDREL FIXING PLATE	2
22	UF3680	FW M10	8
23	UF6371	LW M10	8

ITEM	PART NUMBER	DESCRIPTION	QTY
24	UF6382	HHCS M10-1.5 x 25 mm	2
25	UF3755	SHCS M8-1.25 x 20mm	4
26	UPM6424	SHOCK ABSORBER UPPER	1
27	UF5603	BHCS M5-0.8 x 20mm	8
28	UF7023	LW M5	8
29	UPM4986	LINEAR BEARING 25 mm	2
30	UPM6416	LINEAR BEARING SLIDER	1
31	UPM6950	SHOCK ABSORBER MOUNT	2
32	UPM6423	SHOCK ABSORBER LOWER	1
33	UF0867	LW M8	4
34	UF1821	FW M8	4
35	UPM6406	LOCK BLOCK	1
36	UPM6949	LOWER STOP BLOCK	1
37	UF0458	HHCS M10-1.5 x 20mm	6
38	UPM6428	90° QUICK CONNECTOR	1
39	UPM3124	90° QUICK CONNECTOR	1
40	UPM6426	CHECK VALVE	1
41	UF6300	RETAINING RING 12mm	2
42	UPM6403	CYLINDER PIN	1
43	UPM6422	CYLINDER MOUNT	1
44	UPM6425	20mm X 12.5mm X 7mm SPACER	2

# APPENDIX B

## Right Column

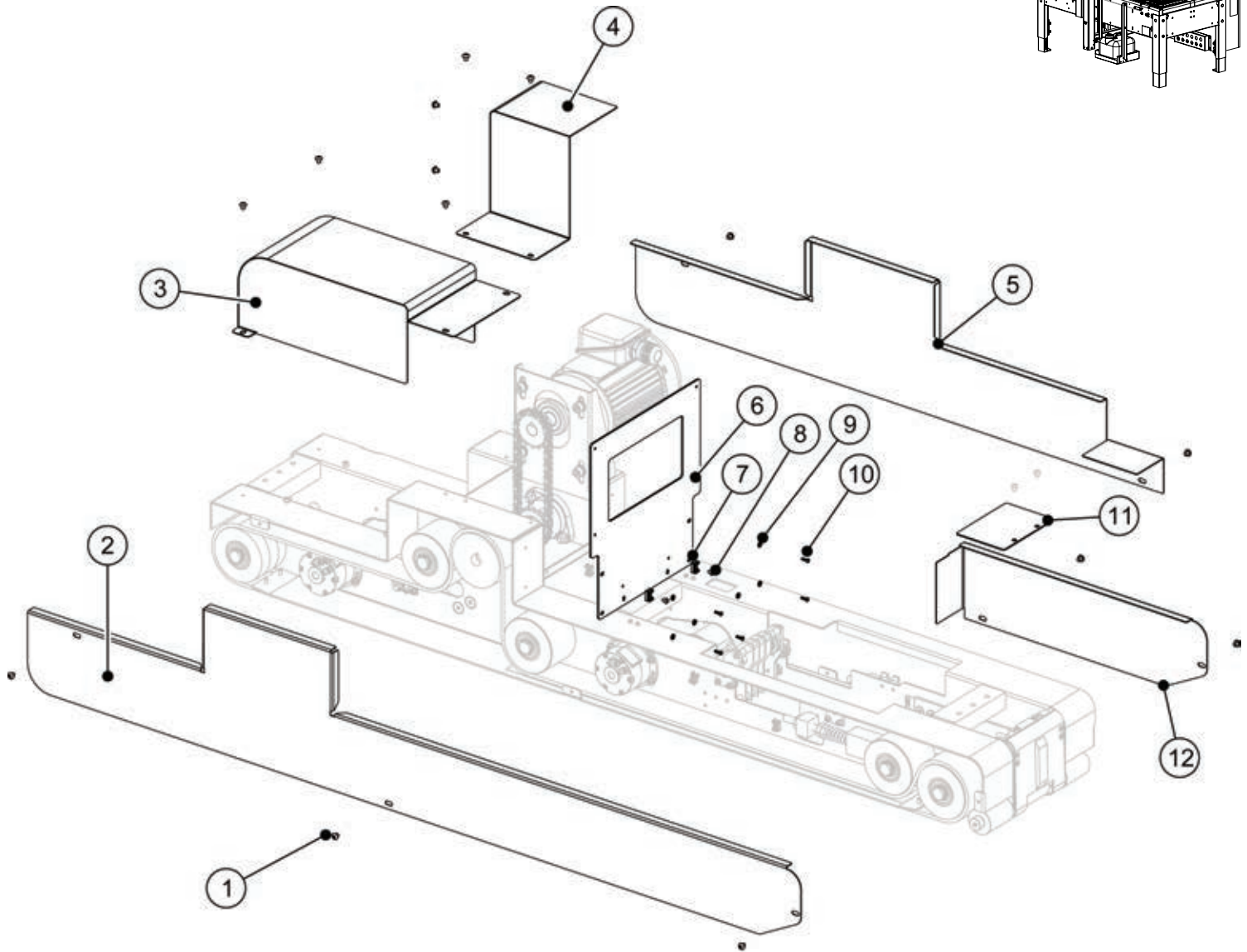
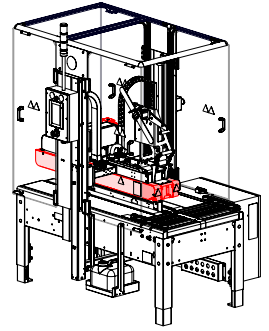


ITEM	PART NUMBER	DESCRIPTION	QTY
1	UPM6423	SHOCK ABSORBER LOWER	1
2	UF5603	BHCS M5-0.8 x 20mm	8
3	UF7023	LW M5	8
4	UPM6416	LINEAR BEARING SLIDER	1
5	UPM4986	LINEAR BEARING 25 mm	2
6	UPM6950	SHOCK ABSORBER MOUNT	2
7	UPM6424	SHOCK ABSORBER UPPER	1
8	UF3755	SHCS M8-1.25 x 20mm	4
9	UF0867	LW M8	4
10	UF1821	FW M8	4
11	UPM6951	UPPER STOP BLOCK	1
12	UF4236	SHCS M6-1 X 30mm	5
13	UF6382	HHCS M10-1.5 x 25 mm	2
14	UF6371	LW M10	2
15	UF3860	FW M10	8
16	UPM6415	MANDREL FIXING PLATE	2
17	UPM1912	SHAFT COLLAR METRIC 25mm	1
18	UPM6419	LINEAR AXIS ROD	1
19	UPM6413	LIFT CONNECTION BLOCK	1
20	UF3648	SHCS M10-1.5 x 16mm	2
21	UPM6417	SLIDER CONNECTING PLATE	1
22	UF3755	SHCS M8-1.25 x 20mm	2
23	UPM6949	LOWER STOP BLOCK	1

ITEM	PART NUMBER	DESCRIPTION	QTY
24	UPM6406	LOCK BLOCK	1
25	UF0457	BHCS M10-1.5 x 20mm	6
26	UF6371	LW M10	6
27	UPM3124	90° QUICK CONNECTOR	1
28	UPM6426	CHECK VALVE	1
29	UPM6428	90° QUICK CONNECTOR	1
30	UPM6425	20MM X 12.5MM X 7MM SPACER	2
31	UPM6403	CYLINDER PIN	1
32	UF6300	RETAINING RING	2
33	UPM6422	CYLINDER MOUNT	1
34	UF5601	BHCS M5 X 0.8 X 6mm	4
35	UF7010	BHCS M5-0.8 x 8 mm	2
36	UPM8117	Cable Tie Mount	2
37	UPM6946	COLUMN COVER	1
38	UF3394	LOCKNUT M5	2
39	UPM5146	SILENCER	1
40	UPM6421	AIR CYLINDER 600MM	1
41	UPM6420	12MM ROD END BEARING RH	1
42	UF4231	FW M12	1
43	UF3733	LW M12	1
44	UF0061	HHCS M12-1.75 x 20mm	1
45	UPM6945	COLUMN	1

# APPENDIX B

## Bridge Cover Panels

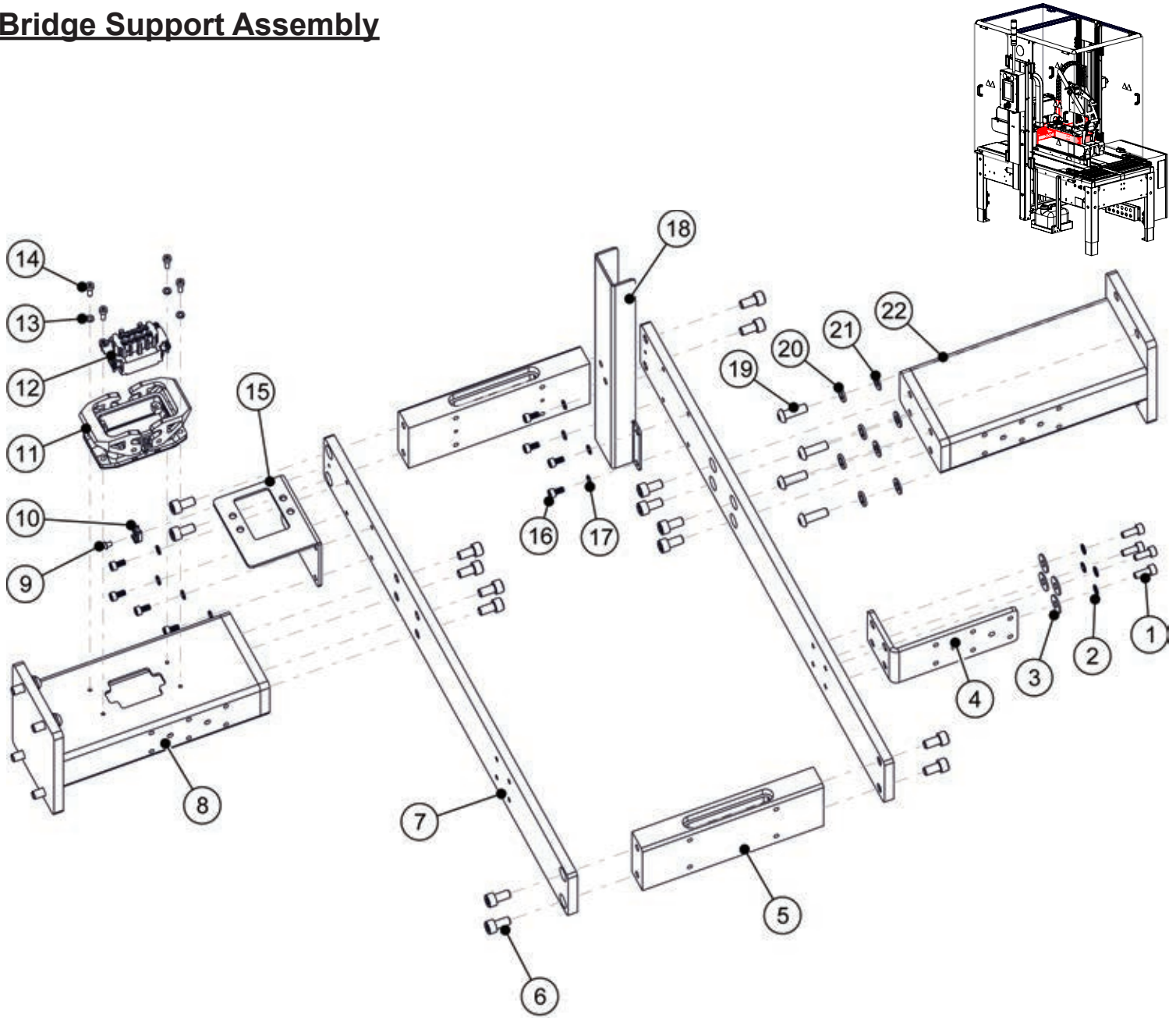


ITEM	PART NUMBER	DESCRIPTION	QTY
1	UF3276	BHCS M5-0.8 x 6mm	16
2	UPM6970	UPPER LEFT BELT COVER	1
3	UPM6971	UPPER REAR COVER	1
4	UPM6959	UPPER CHAIN COVER	1
5	UPM6975	UPPER RIGHT BELT COVER - REAR	1
6	UPM6985	UPPER ELEC BOX MOUNT	1
7	UPM6808	CABLE TIE MOUNT	2

ITEM	PART NUMBER	DESCRIPTION	QTY
8	UF7008	BHCS M4-0.7 x 6mm	2
9	UF3749	LW M4	6
10	UF6365	BHCS M4-0.7 x 10mm	6
11	UPM7453	UPPER FRONT COVER	1
12	UPM6974	UPPER RIGHT BELT COVER - FRONT	1

# APPENDIX B

## Bridge Support Assembly

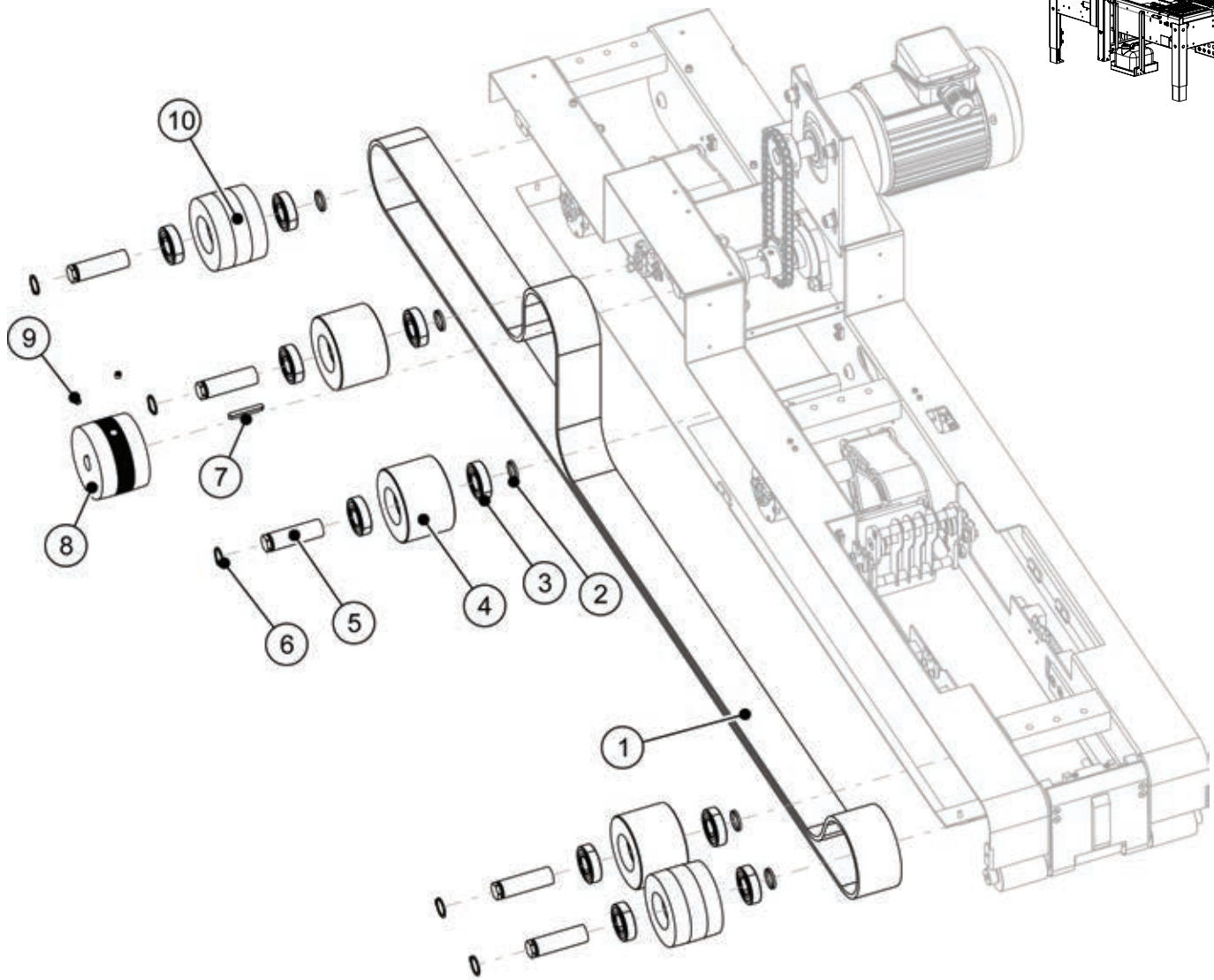
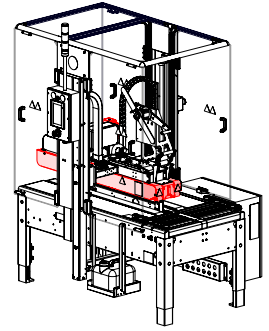


ITEM	PART NUMBER	DESCRIPTION	QTY
1	UF3187	SHCS M6-1 x 16 mm	4
2	UF6411	LW M6	4
3	UF1890	FLAT WASHER	4
4	UPM6979	UPPER MANDREL MOUNT SUPPORT	1
5	UPM6955	BRIDGE FRAME CROSS BAR	2
6	UF6367	SHCS M8-1.25 x 16mm	16
7	UPM6958	BRIDGE FRAME SIDE PLATE	2
8	UPM6956	BRIDGE FRAME LEFT ARM	1
9	UF7008	BHCS M4-0.7 x 6mm	1
10	UPM6808	CABLE TIE MOUNT	1
11	UPM6886	10 POS HEAVY DUTY MOUNT BASE	1
12	UPM6885	10 POS HEAVY DUTY SOCKET	1

ITEM	PART NUMBER	DESCRIPTION	QTY
13	UF3681	LW M4	4
14	UF3801	SHCS M4-0.7 x 12mm	4
15	UPM6972	POWER E-CHAIN BRIDGE MOUNT	1
16	UF5201	SHCS M5-0.8 x 10mm	8
17	UF7023	LW M5	8
18	UPM6952	AIR E-CHAIN BRIDGE MOUNT	1
19	UF3763	BHCS M8-1.25 x 25mm	8
20	UF0867	LW M8	8
21	UF1821	FW M8	8
22	UPM6957	BRIDGE FRAME RIGHT ARM	1

# APPENDIX B

## Top Left Drive

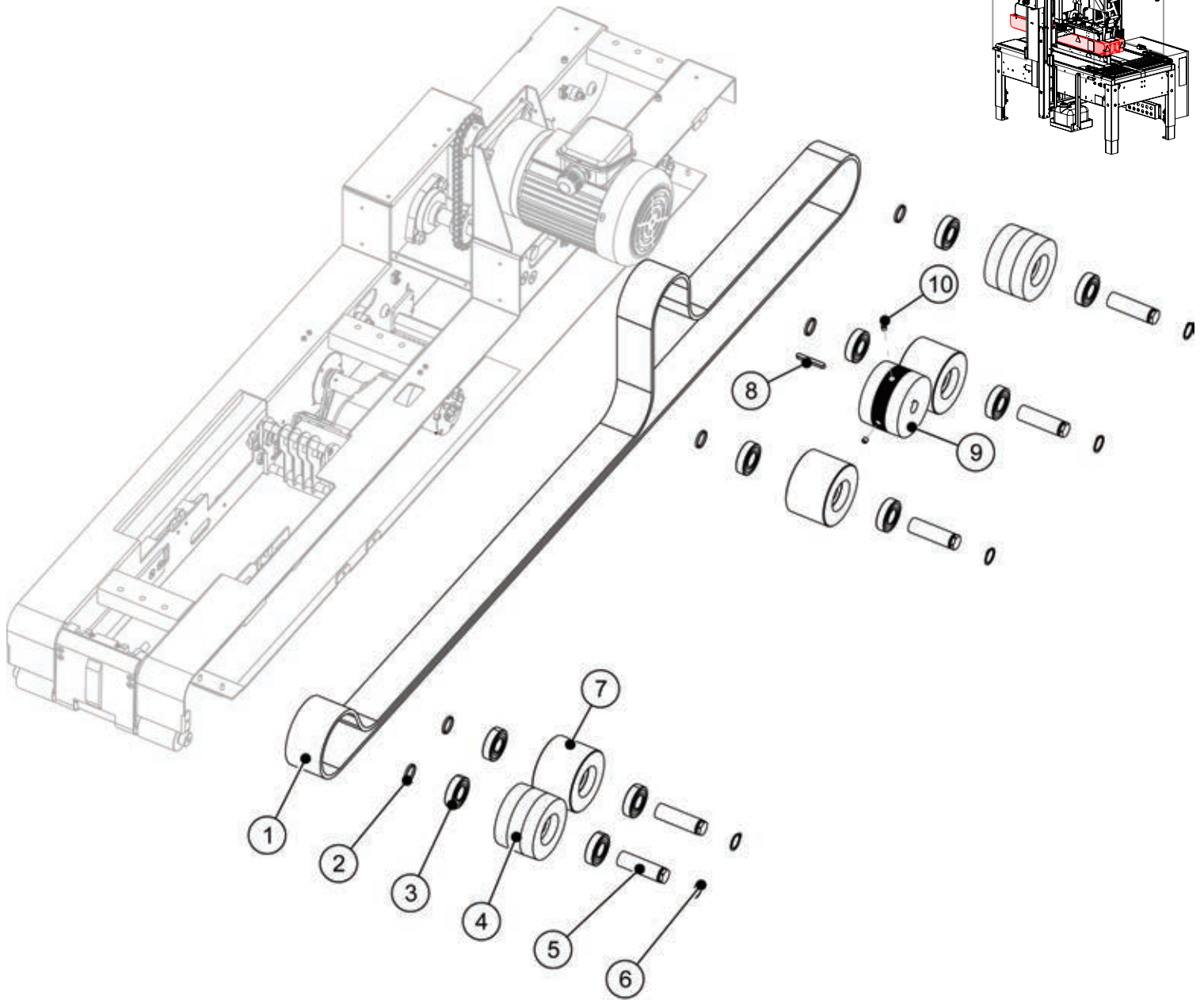


ITEM	PART NUMBER	DESCRIPTION	QTY
1	UPM6888	BELT 50mm X 2896mm	1
2	UPM6317	SPACER	5
3	UPM0324	BALL BEARING	10
4	UPM6991	BACKFLEX IDLER PULLEY	3
5	UPM6986	IDLER SHAFT	5
6	UF2220EV	EXT RET'G RING	5

ITEM	PART NUMBER	DESCRIPTION	QTY
7	UF0194	KEY 5x5-40mm	1
8	UPM4450	DRIVE PULLEY	1
9	UF1411	SSS M6 X 6mm	2
10	UPM0259	IDLER PULLEY	2

# APPENDIX B

## Top Right Drive

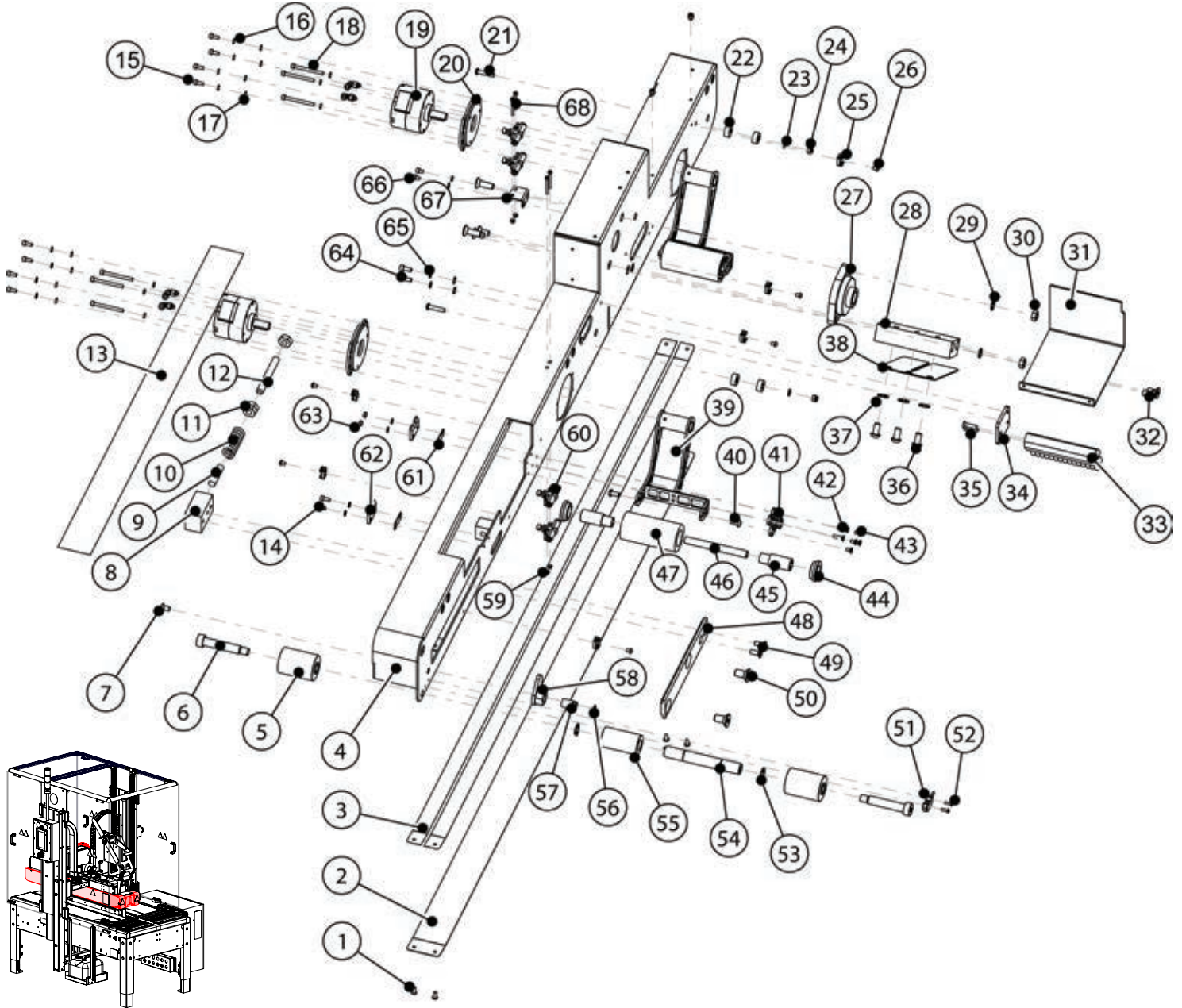


ITEM	PART NUMBER	DESCRIPTION	QTY
1	UPM6888	BELT 50mm X 2896mm	1
2	UPM6317	SPACER	5
3	UPM0324	BALL BEARING	10
4	UPM0259	IDLER PULLEY	2
5	UPM6986	IDLER SHAFT	5
6	UF2220EV	RETAINING RING	5

ITEM	PART NUMBER	DESCRIPTION	QTY
7	UPM6991	BACKFLEX IDLER PULLEY	3
8	UF0194	KEY 5x5-40mm	1
9	UPM4450	DRIVE PULLEY	1
10	UF1411	SSS M6 x 6mm	2

# APPENDIX B

## Top Left Drive Frame



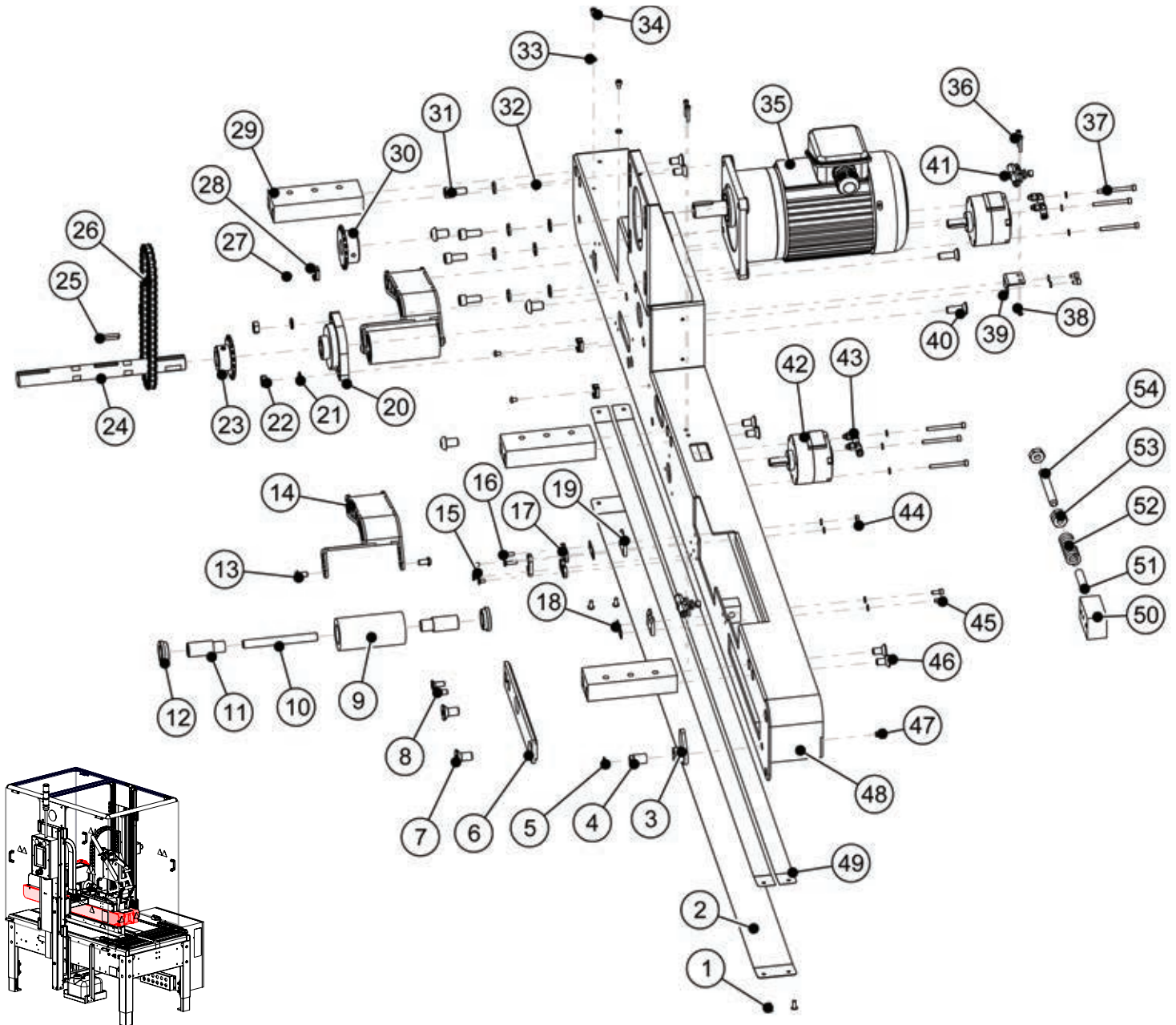
ITEM	PART NUMBER	DESCRIPTION	QTY
1	UF3691	POP RIVET 4mm	4
2	UPM6976	BELT GUIDE STRIP	1
3	UF6438	ADHESIVE STRIP	2
4	UPM6987	LEFT DRIVE FRAME	1
5	UPM6332	SIDE ROLLER SENSOR PLATE	2
6	UF0123	M12 SHOULDER SCREW	2
7	UF6353	FHCS M6-1.0 x 12mm	1
8	UPM1234	BELT TENSION BLOCK	1
9	UPM0112	SPRING LOCATOR PIN	1
10	UPM0038	DIE SPRING (DRIVE BASE)	1
11	UF1540	HNR 3/8" -16	3
12	UF1400	TENSIONER ROD	1
13	UPM8118	BELT INNER GUIDE TAPE	1
14	UF9148	SHCS M4-0.7 x 10mm	2
15	UF3759	SHCS M4-0.7 x 10mm	8
16	UF3749	LW M4	20
17	UPH4905	ELBOW FITTING	12
18	UF0173	SHCS M4-0.7 x 45mm	6
19	WET0343	ROTARY ACTUATOR	2
20	WET0283	FRONT ARM ACTUATOR MOUNT	2
21	UF3279	BHCS M5-0.8 X 25mm	2
22	UPH4613	KNIFE ARM BUMPER	4
23	UF0263	FW M5	4

ITEM	PART NUMBER	DESCRIPTION	QTY
24	UF3394	LOCK NUT M5-0.8	2
25	UPM6808	CABLE TIE MOUNT	6
26	UF7008	BHCS M4-0.7 x 6mm	6
27	UPM0069	FLANGE BEARING	1
28	UPM6983	DRIVE SPACER	1
29	UF3640	LW M8	2
30	UF0866	HEX NUT M8	2
31	UPM6960	UPPER CHAIN GUARD	1
32	UF3684	FHCS M8-1.25 x 16mm	4
33	UPH4004	BRUSH	1
34	UPM6981	UPPER BRUSH MOUNT	1
35	UF3721	FHCS M5-0.8 x 20mm	2
36	UF0252	BHCS M8-1.25 x 16 mm	3
37	UF1821	FW M8	3
38	UPM6926	DEFLECTOR	1
39	WET0284	BOTTOM ROLLER ARM	1
40	UF3278	BHCS M6-1 x 12 mm	2
41	WET0255	TAPE CHUTE DETENT	3
42	UF5454	FHCS M4-0.7 x 16mm	2
43	UF3274	FHCS M4-0.7 x 8 mm	4
44	WET0202	COLLAR	2
45	WET0201	ROLLER CORE	2
46	WET0203	SHAFT, dia 10	1

ITEM	PART NUMBER	DESCRIPTION	QTY
47	WET0005	WIPE ARM ROLLER REAR	1
48	UPM6988	LEFT TENSIONER SLIDE	1
49	UF3261	FHCS M6-1.0 x 16mm	2
50	UF6397	FHCS M10-1.5 x 20mm	2
51	UPM7452	PHOTOEYE	1
52	UF4318	BHCS M3-0.5 x 10mm	2
53	UF4314	RETAINING RING	2
54	UPM6328	SPINDLE ROLLER	1
55	UPM6331	ROLLER SENSOR PLATE	1
56	UF3558	RETAINING RING	1
57	UPM6316	ADJUSTER MANDREL	1
58	UPM6314	BELT TENSIONER LH	1
59	UF0165	LOCK NUT M3-0.5	4
60	UPM7456	INLINE FLOW CONTROL	4
61	UPM6954	TAPEHEAD GUIDE SPACER	2
62	UPM6953	TAPEHEAD GUIDE	2
63	UF4237	HEX NUT M4-0.7	2
64	UF9154	SHCS M5-0.8 x 12mm	2
65	UF7023	LW M5	2
66	UF4312	SHCS M4-0.7 x 6mm	2
67	UPM6969	FLOW CONTROL	1
68	UF4307	SHCS M3-0.5 x 30mm	4

# APPENDIX B

## Top Right Drive Frame



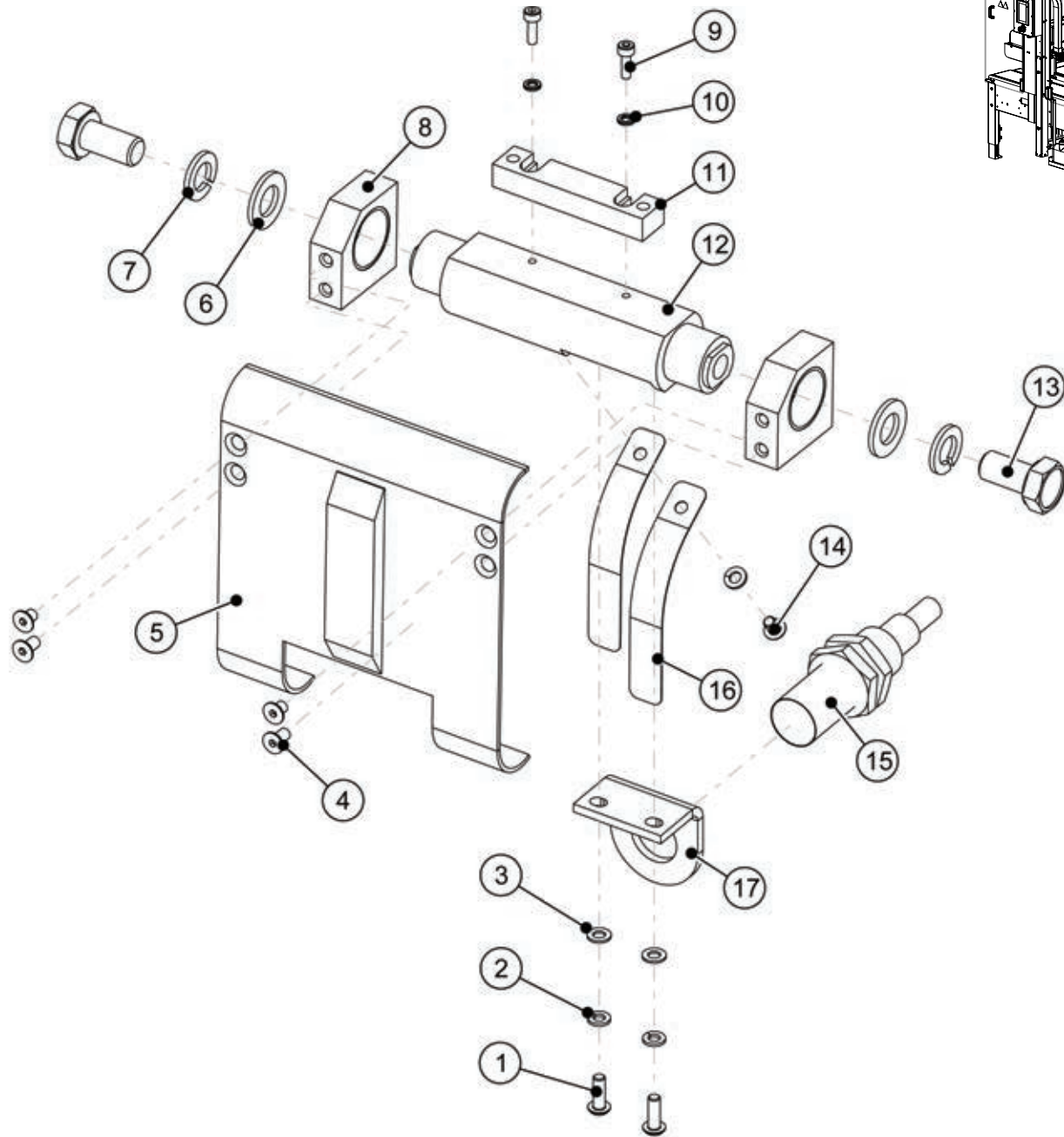
ITEM	PART NUMBER	DESCRIPTION	QTY
1	UF3691	POP RIVET 4mm	4
2	UPM6976	UPPER BELT GUIDE STRIP	1
3	UPM6315	BELT ADJUSTER RH	1
4	UPM6316	ADJUSTER MANDREL	1
5	UF3558	RETAINING RING	1
6	UPM6990	RIGHT TENSIONER SLIDE	1
7	UF1191	FHCS M10-1.5 x 20mm	2
8	UF1192	FHCS M6-1.0 x 16mm	2
9	WET0005	WIPE ARM ROLLER REAR	1
10	WET0203	SHAFT, dia 10	1
11	WET0201	ROLLER CORE	2
12	WET0202	COLLAR	2
13	UF3278	BHCS M6-1 x 12 mm	4
14	WET0284	BOTTOM ROLLER ARM	2
15	UF3274	FHCS M4-0.7 x 8 mm	4
16	UF4500	FHCS M4-0.7 X 16mm	2
17	WET0255	TAPE CHUTE DETENT	3
18	UPM6954	TOP GUIDE SPACER	2
19	UPM6953	TAPEHEAD GUIDE	2

ITEM	PART NUMBER	DESCRIPTION	QTY
20	UPM0069	FLANGE BEARING 3/4" ID	1
21	UF0867	LW M8	6
22	UF3735	HNR M8-1.25	2
23	UPM6319	SPROCKET	1
24	UPM6984	UPPER DRIVE SHAFT	1
25	UF0194	KEY 5x5-30mm	1
26	UPM6982	UPPER DRIVE CHAIN	1
27	UF7008	BHCS M4-0.7 x 6mm	3
28	UPM6808	CABLE TIE MOUNT	3
29	UPM6983	UPPER DRIVE SPACER	3
30	UPM6318	DRIVE SPROKET	1
31	UF3755	SHCS M8-1.25 x 20mm	4
32	UF1821	FW M8	4
33	UF3749	LW M4	12
34	UF4312	SHCS M4-0.7 x 6mm	4
35	UPM6789	MOTOR	1
36	UF3790	SHCS M3-0.5 x 20mm	4
37	UF0173	SHCS M4-0.7 x 45mm	6
38	UF0165	M3-0.5 LOCK NUT	2

ITEM	PART NUMBER	DESCRIPTION	QTY
39	UPM6969	FLOW CONTROL MOUNT	1
40	UF0091	FHCS M8-1.25 x 25mm	2
41	UPM7456	FLOW CONTROL	2
42	WET0343	ROTARY ACTUATOR	2
43	UPH4905	M5 x 4mm ELBOW FITTING	4
44	UF4237	HEX NUT M4-0.7	2
45	UF9148	SHCS M4-0.7 x 10mm	2
46	UF3684	FHCS M8-1.25 x 16mm	6
47	UF1042	FHCS M6-1.0 x 12mm	1
48	UPM6989	UPPER RIGHT DRIVE FRAME	1
49	UF6438	ADHESIVE TAPE	2
50	UPM1234	TENSION BLOCK	1
51	UPM0112	SPRING LOCATOR PIN	1
52	UPM0038	DIE SPRING	1
53	UF1540	NUT 3/8"-16	3
54	UF1400	SSS 3.8-16 x 3.0"	1

# APPENDIX B

## Front Paddle

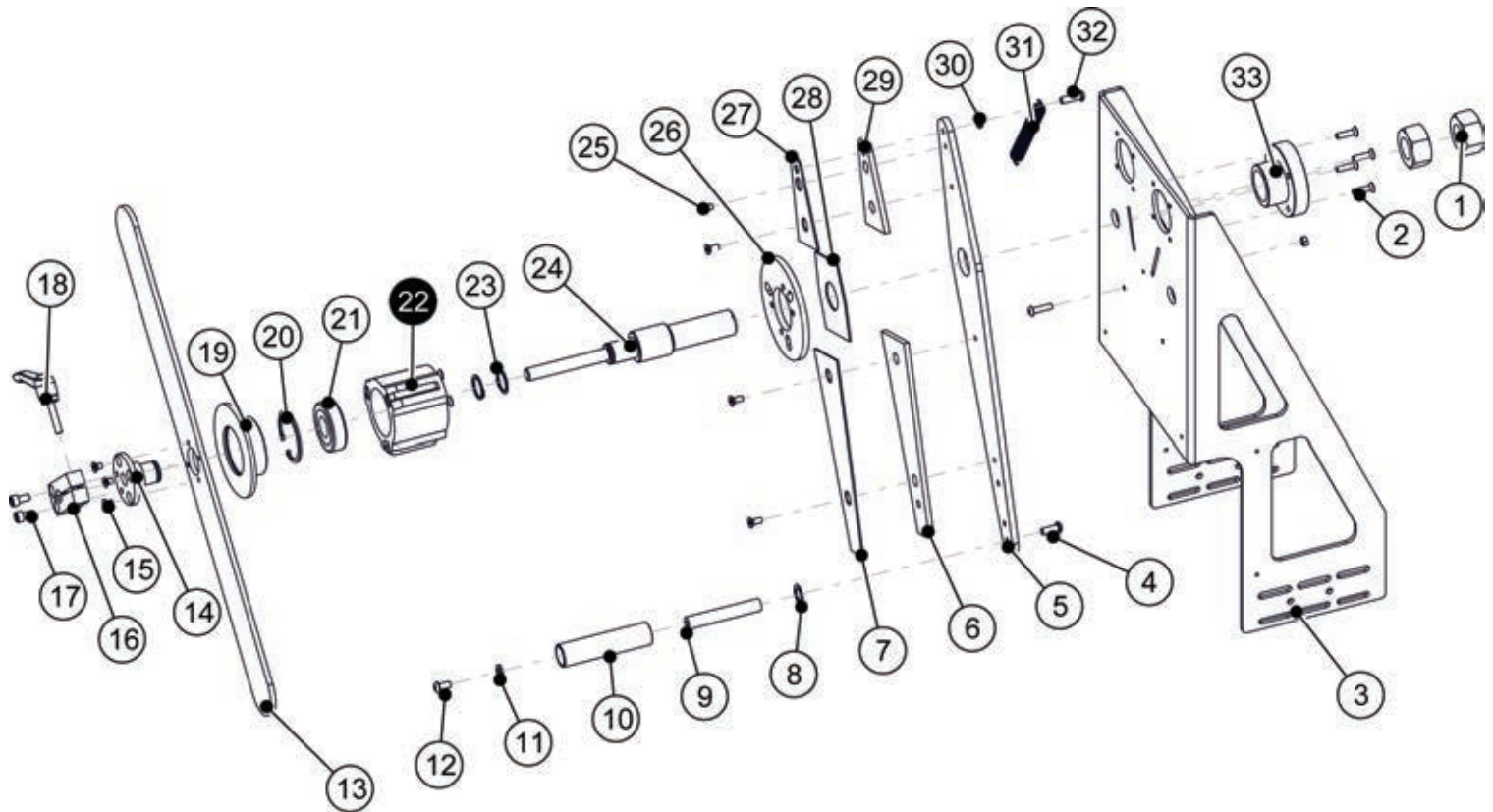
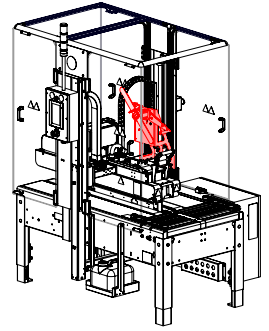


ITEM	PART NUMBER	DESCRIPTION	QTY
1	UF3649	BHCS M4-0.7 x 12mm	2
2	UF3681	LW M4	3
3	UF6339	FW M4	2
4	UF5401	FHCS M4-0.7 x 6 mm	4
5	UPM6329	SENSOR PLATE	1
6	UF3680	FW M10	2
7	UF6371	LW M10	2
8	UPM2129	SENSOR PIVOT BLOCK	2
9	UF5200	SHCS M3-0.5 x 10mm	2

ITEM	PART NUMBER	DESCRIPTION	QTY
10	UF3718	LW M3	2
11	UPM6333	CONTACT BLOCK	1
12	UPM6330	SENSOR PLATE SHAFT	1
13	UF3679	HHCS M10-1.5 x 20mm	2
14	UF6374	BHCS M4-0.7 x 6mm	1
15	UPM8097	PROXIMITY SENSOR NPN	1
16	UPM0011	SPRING BLADE	2
17	UPM0733	MOUNTING BRACKET	1

# APPENDIX B

## Top Tape Mandrel

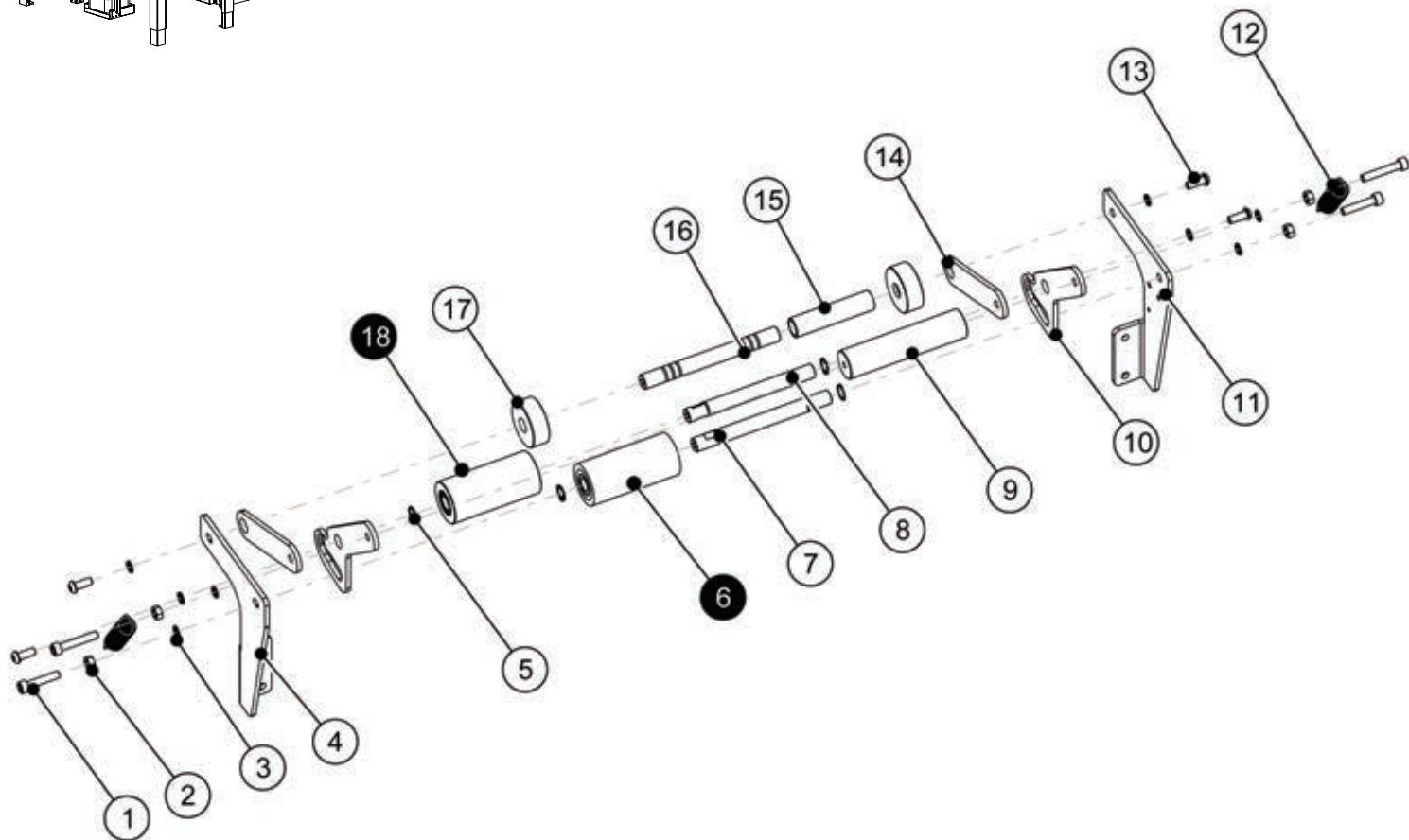
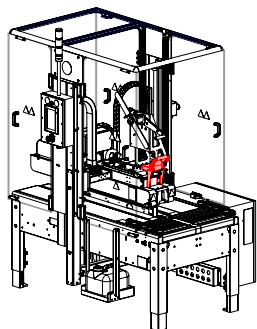


ITEM	PART NUMBER	DESCRIPTION	QTY
1	UF3816	HEX NUT M24-1.5	2
2	UF3721	FHCS M5-0.8 x 20mm	4
3	UPM6978	UPPER MANDREL MOUNT	1
4	UF6414	BHCS M6-1 x 16mm	1
5	UPM6964	BRAKE ARM - RIGHT HAND	1
6	UPM6965	BRAKE ARM - FRONT SPACER	1
7	UPM6966	BRAKE ARM - FRONT PAD	1
8	UF6336	FW PTFE	1
9	UPH0949	GUIDE ROLLER SHAFT	1
10	UPH9059	PEEL OFF ROLLER	1
11	UF6341	FW M6	1
12	UF3278	BHCS M6-1 x 12 mm	1
13	UPM5108	CROSS BAR	1
14	UPM5106	RETAINER	1
15	UF7024	FHCS M5-0.8 x 8mm	3
16	UPM5107	CLAMPING	1
17	UF3183	SHCS M6-1 x 12mm	2

ITEM	PART NUMBER	DESCRIPTION	QTY
18	UPM4889	HANDLE	1
19	UPM5104	FLANGE MANDREL	1
20	UF0276	RETAINING RING	1
21	UPM4888	BALL BEARING	1
22	UAM0195	MANDREL HUB	1
23	UF3815	RETAINING RING	2
24	UPM5109	STEPPED SHAFT	1
25	UF3282	FHCS M5-0.8 x 12mm	4
26	UPM6977	MANDREL BRAKE DISK	1
27	UPM6968	BRAKE ARM - REAR PAD	1
28	UPM9802	BREAK PAD	1
29	UPM6967	BRAKE ARM - REAR SPACER	1
30	UF6307	HEX NUT M5-0.8	2
31	UPM4498	EXTENSION SPRING	1
32	UF6325	BHCS M6-1 x 20mm	2
33	UPM5114	HUB	1

# APPENDIX B

## Top Clutch Assembly

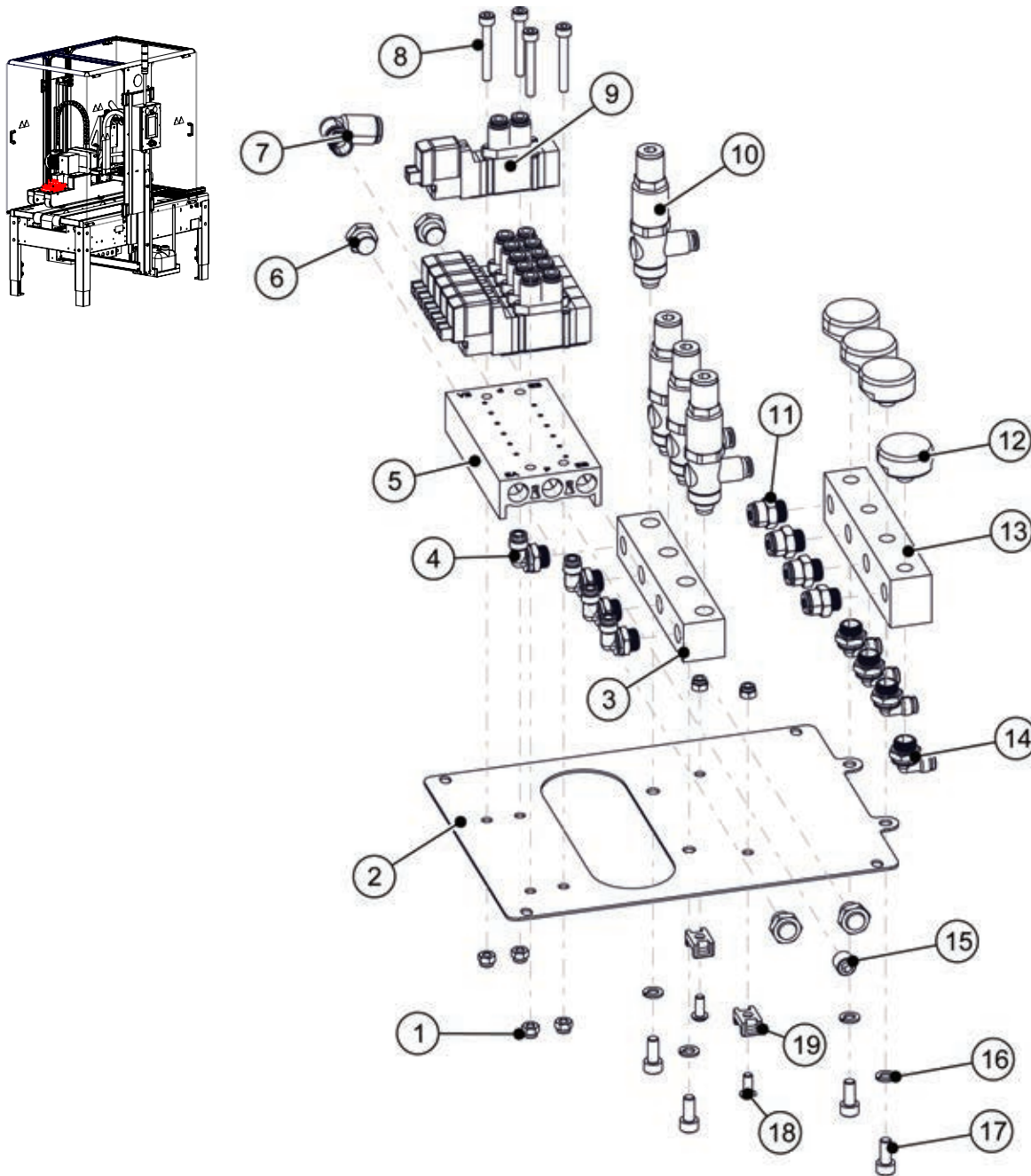


ITEM	PART NUMBER	DESCRIPTION	QTY
1	UF0850	SHCS M6-1 X 35mm	4
2	UF3637	HNR M6-1.0	4
3	UF6363	LW M6	8
4	UPM6961	CLUTCH BRACKET LEFT	1
5	UF6300	RETAINING RING	4
6	UAM0033	CLUTCH ROLLER	1
7	UPM5906	CLUTCH ROLLER SHAFT	1
8	UPM5907	PINCH ROLLER SHAFT	1
9	UPM5909	CLAMP ARM HANDLE	1
10	UPM5910	CLAMP ARM	2

ITEM	PART NUMBER	DESCRIPTION	QTY
11	UPM6962	CLUTCH BRACKET RIGHT	1
12	UPM5999	SPRING	2
13	UF6414	BHCS M6-1 x 16mm	4
14	UPM5908	PIVOT ARM	2
15	UPM4667	IDLER ROLLER	1
16	UPM5903	PIVOT SHAFT	1
17	UPM2485	ADJUSTMENT RING	2
18	UAM0034	PINCH ROLLER	1

# APPENDIX B

## Top Pneumatic Valve Assembly

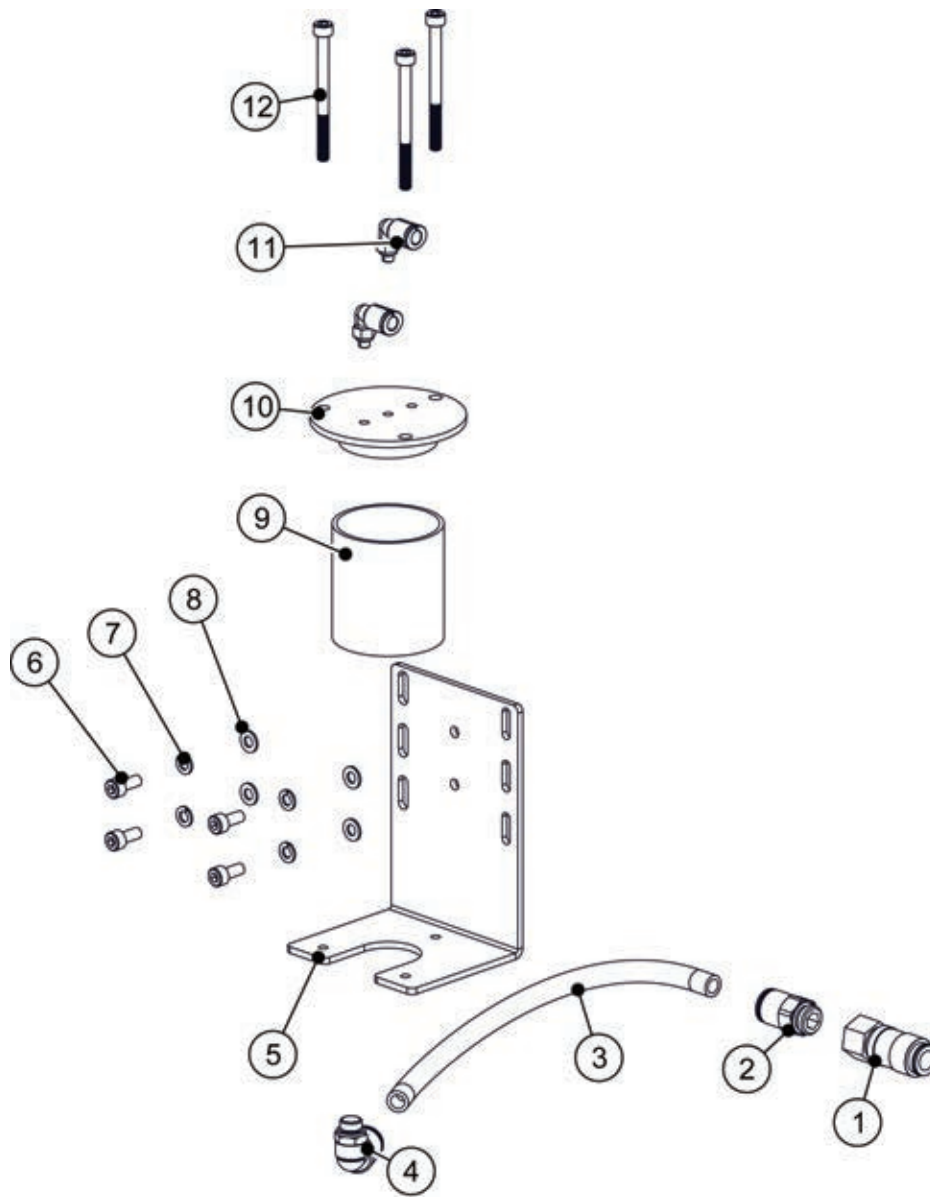
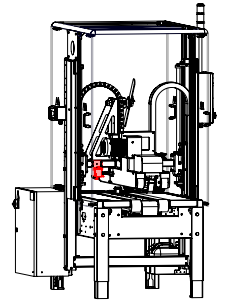


ITEM	PART NUMBER	DESCRIPTION	QTY
1	UF6376	LOCKNUT M4	6
2	UPM6993	UPPER MANIFOLD MOUNT	1
3	UPM6994	REGULATOR MANIFOLD	1
4	UPM6875	ELBOW 1/8G X 4mm	4
5	UPM6881	MANIFOLD 6 POS	1
6	UPH4903	FLAT MUFFLER G1/8	4
7	UPM6876	ELBOW FITTING 8MM X 1/8BSPT	1
8	UF9156	SHCS M4-0.7 x 30mm	4
9	WET0344	VALVE	6
10	WET0211	PRESSURE REGULATOR	4

ITEM	PART NUMBER	DESCRIPTION	QTY
11	UPM6877	STRAIGHT FITTING 1/8G X 4mm	4
12	UPM6880	PRESSURE GAUGE R1/16	4
13	UPM6992	GAUGE MANIFOLD	1
14	UPM6875	ELBOW 1/8G X 4mm	4
15	UPM8001	PLUG, 1/8" BSPT	1
16	UF7023	LW M5	4
17	UF9154	SHCS M5-0.8 X 12	4
18	UF6364	BHCS M4 x 0.7 x 10mm	2
19	UPM6808	CABLE TIE MOUNT	2

# APPENDIX B

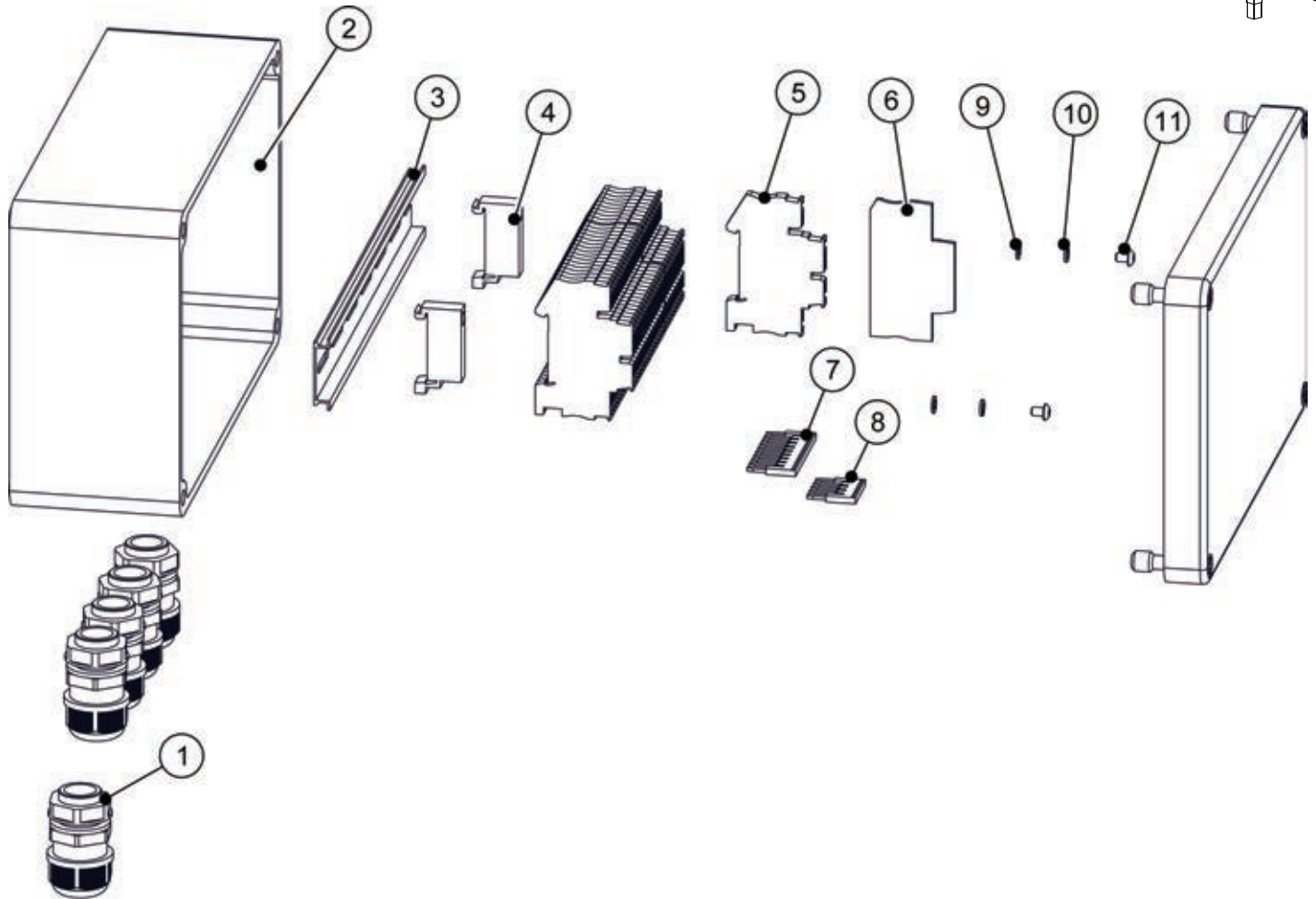
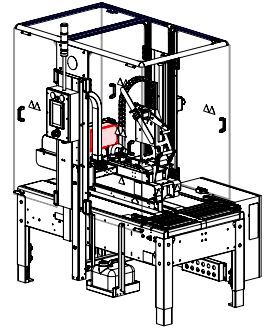
## Top Water Cup



ITEM	PART NUMBER	DESCRIPTION	QTY
1	UPH4921	FEMALE DISCONNECT COUPLING H2O	1
2	UPM5543	10mm TUBE X 1/4G STR FITTING	1
3	UPM8177	WATER TUBE TOP	1
4	UPM5151	ELBOW FITTING, 10 ID	1
5	UPM6915	RESERVOIR BRACKET	1
6	UF9154	SHCS M5-0.8 x 12mm	4
7	UF7023	LW M5	4
8	UF6340	FW M5	4
9	UPM5536	RESERVOIR CUP - 10mm TUBE	1
10	UPM6916	RESERVOIR CAP	1
11	UPM6874	ELBOW FITTING 5mm X 6mm	2
12	UF0262	SHCS, M5-0.8 x 60mm	3

# APPENDIX B

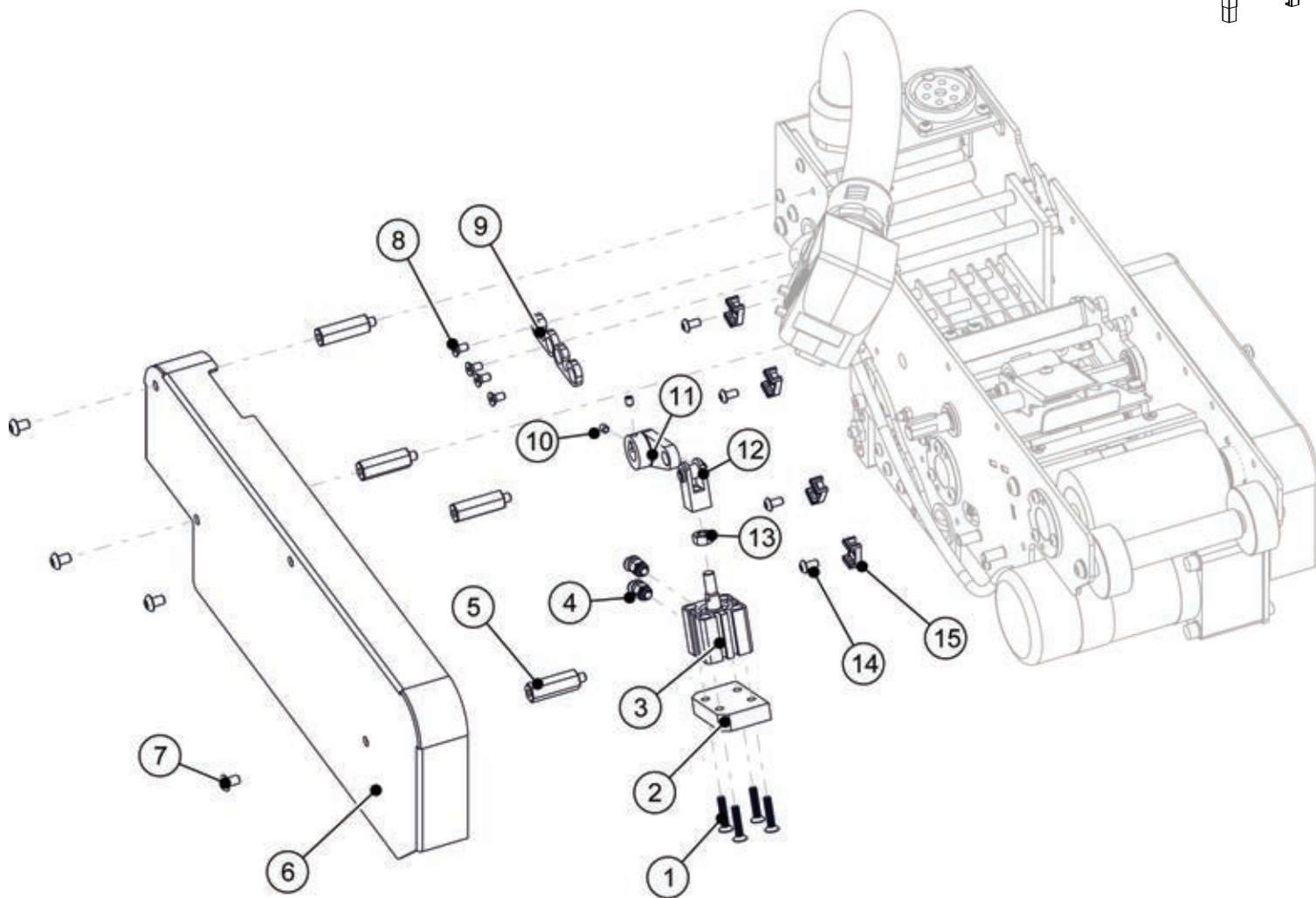
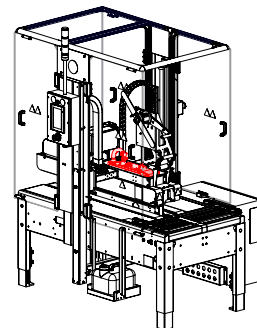
## Top Sub-Electrical Box



ITEM	PART NUMBER	DESCRIPTION	QTY
1	UPM5873	CABLE GLANDS	5
2	UPM8061	ELECTRICAL BOX	1
3	UPM6904	ELEC BOX DIN RAIL	1
4	UPM7440EV	DIN RAIL ANCHOR	2
5	UPM6193	DOUBLE LEVEL TERMINAL BLOCK	25
6	UPM6195	END COVER	2
7	UPM6199	10 PIN BRIDGE	1
8	UPM6198	5 PIN BRIDGE	1
9	UF3710	FW M4	2
10	UF3749	LW M4	2
11	UF6374	BHCS M4-0.7 x 6mm	2

# APPENDIX B

## Top Tapehead Left Hardware 1

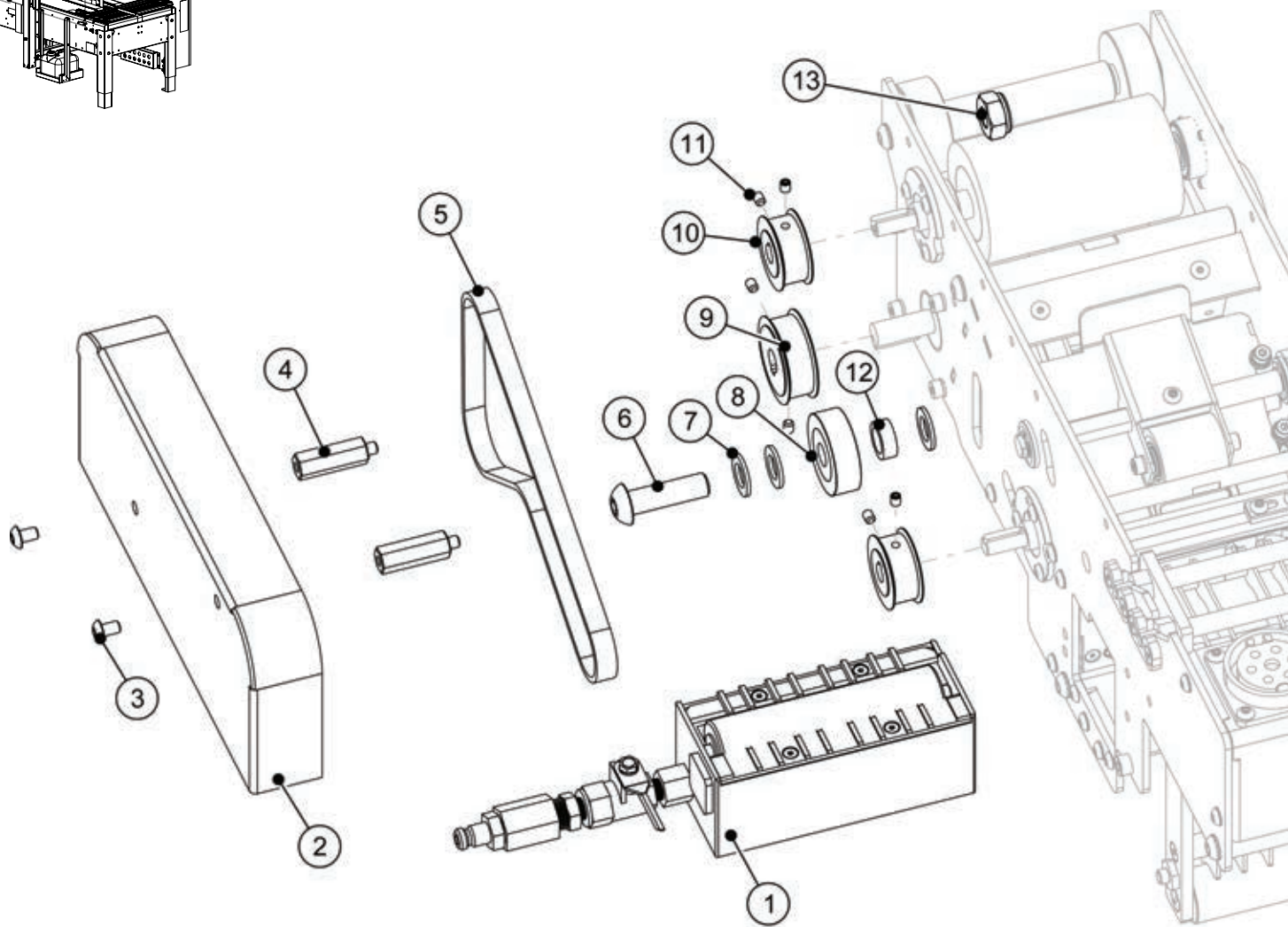
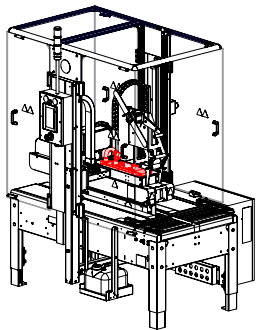


ITEM	PART NUMBER	DESCRIPTION	QTY
1	UF0169	FHCS M4-0.7 x 20mm	4
2	WET0280	CYLINDER SUPPORT	1
3	WET0151	CYLINDER	1
4	UPH4906	STRAIGHT FITTING	2
5	WET0216	ADAPTOR, 30L	4
6	WET0322	TOP TAPEHEAD LEFT COVER	1
7	UF7010	BHCS M5-0.8 x 8 mm	4
8	UF3274	FHCS M4-0.7 x 8 mm	4

ITEM	PART NUMBER	DESCRIPTION	QTY
9	WET0255	TAPE CHUTE DETENT	2
10	UF0171	SSS M4-0.7 x 5mm	2
11	WET0282	TOP PIVOT ARM	1
12	WET0152	CLEVIS	1
13	UF3638	HNR M6-1.0	1
14	UF7009	BHCS M4-0.7 x 8mm	4
15	UPM6808	CABLE TIE MOUNT	4

# APPENDIX B

## Top Tapehead Belt Assembly

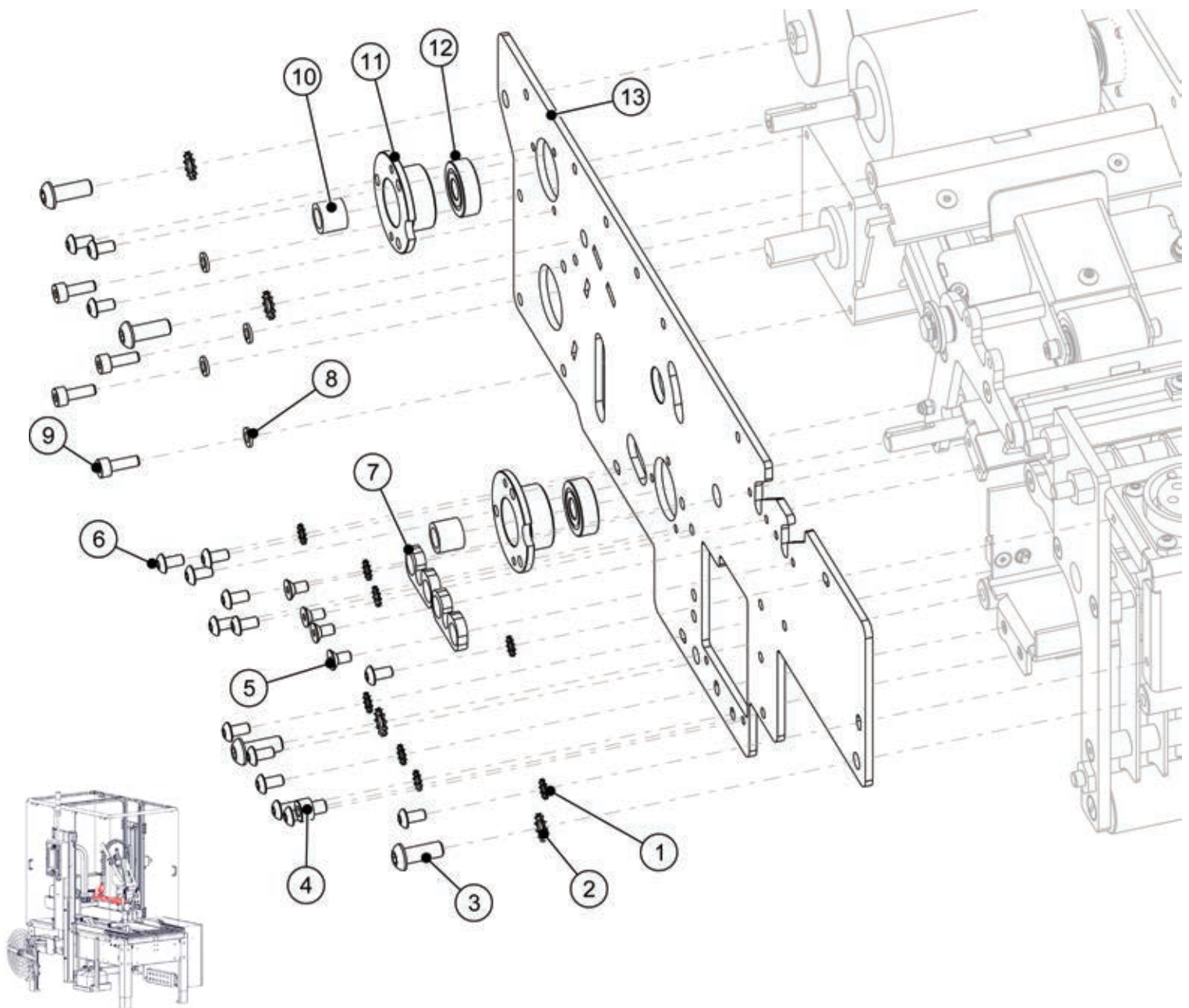


ITEM	PART NUMBER	DESCRIPTION	QTY
1	WST0142	TOP WATER POT TB	1
2	WET0321	TOP TAPEHEAD RIGHT COVER	1
3	UF7010	BHCS M5-0.8 x 8 mm	2
4	WET0216	ADAPTOR, 30L	2
5	WET0250	TIMING BELT 477-3M-9	1
6	UF0072	BHCS M10-1.5 x 35mm	1
7	UF0175	FW M10	3

ITEM	PART NUMBER	DESCRIPTION	QTY
8	UPH4919	BALL BEARING	1
9	WET0368	36 TOOTH TIMING BELT PULLEY	1
10	WET0388	30 TOOTH TIMING BELT PULLEY	2
11	UF0171	SSS M4-0.7 x 12mm	6
12	WET0194	SPACER, dia 16,6L	1
13	UF0224	LOCK NUT M10-1.5	1

# APPENDIX B

## Top Tapehead Right Hardware

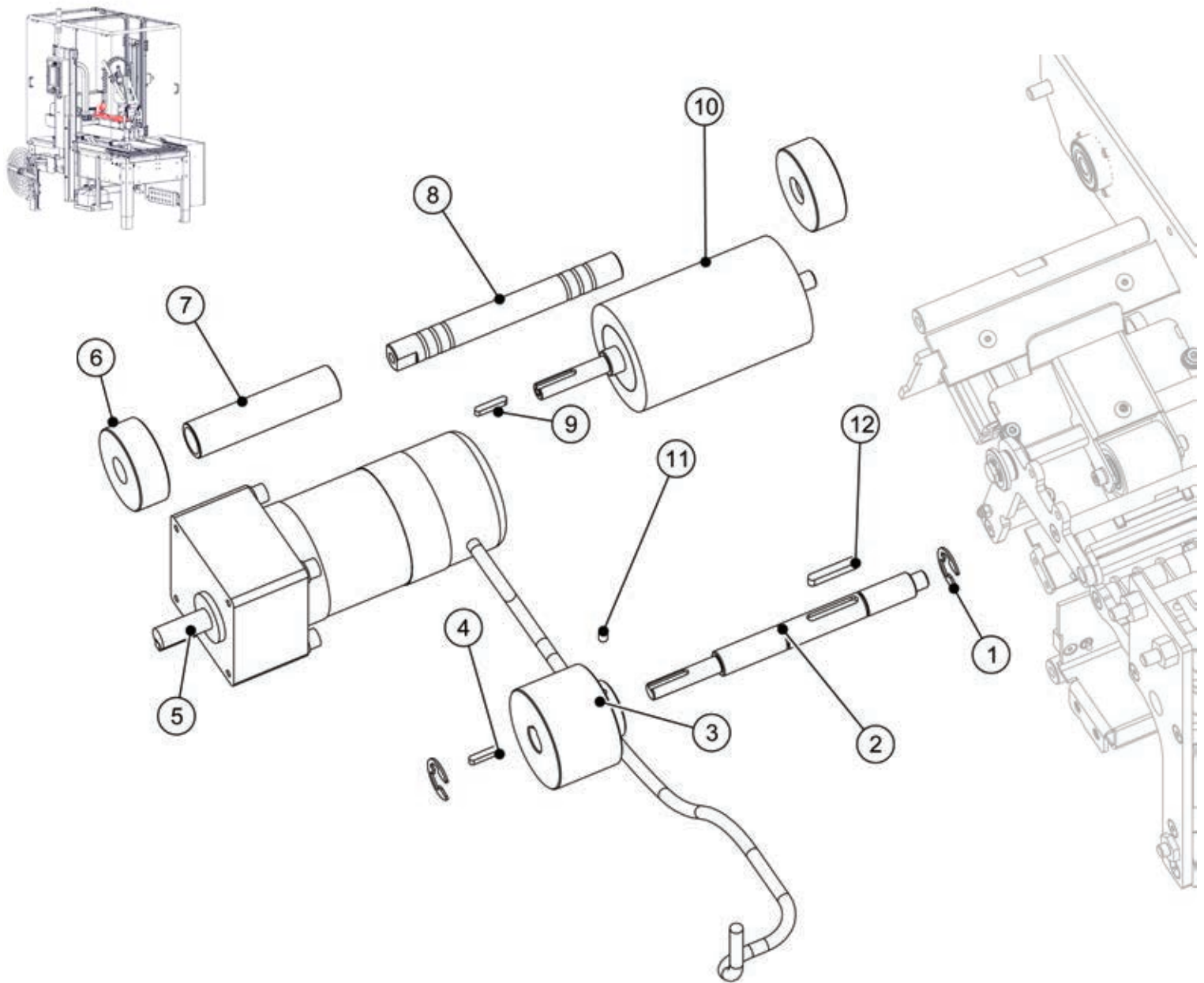


ITEM	PART NUMBER	DESCRIPTION	QTY
1	UF0166	EXTERNAL TOOTH LW M4	8
2	UF0168	EXTERNAL TOOTH LW M6	4
3	UF6414	BHCS M6-1 x 16mm	4
4	UF3149	SHCS M5-0.8 x 6mm	1
5	UF3274	FHCS M4-0.7 x 8mm	4
6	UF7009	BHCS M4-0.7 x 8mm	16
7	WET0255	TAPE CHUTE DETENT	2

ITEM	PART NUMBER	DESCRIPTION	QTY
8	UF3749	LW M4	4
9	UF3801	SHCS M4-0.7 x 12mm	4
10	WET0355	DRIVE SHAFT SPACER	2
11	WET0253	BEARING MOUNT	2
12	WET0341	BALL BEARING	2
13	WET0313	TOP RIGHT FRAME PLATE	1

# APPENDIX B

## Top Tapehead Drive Assembly

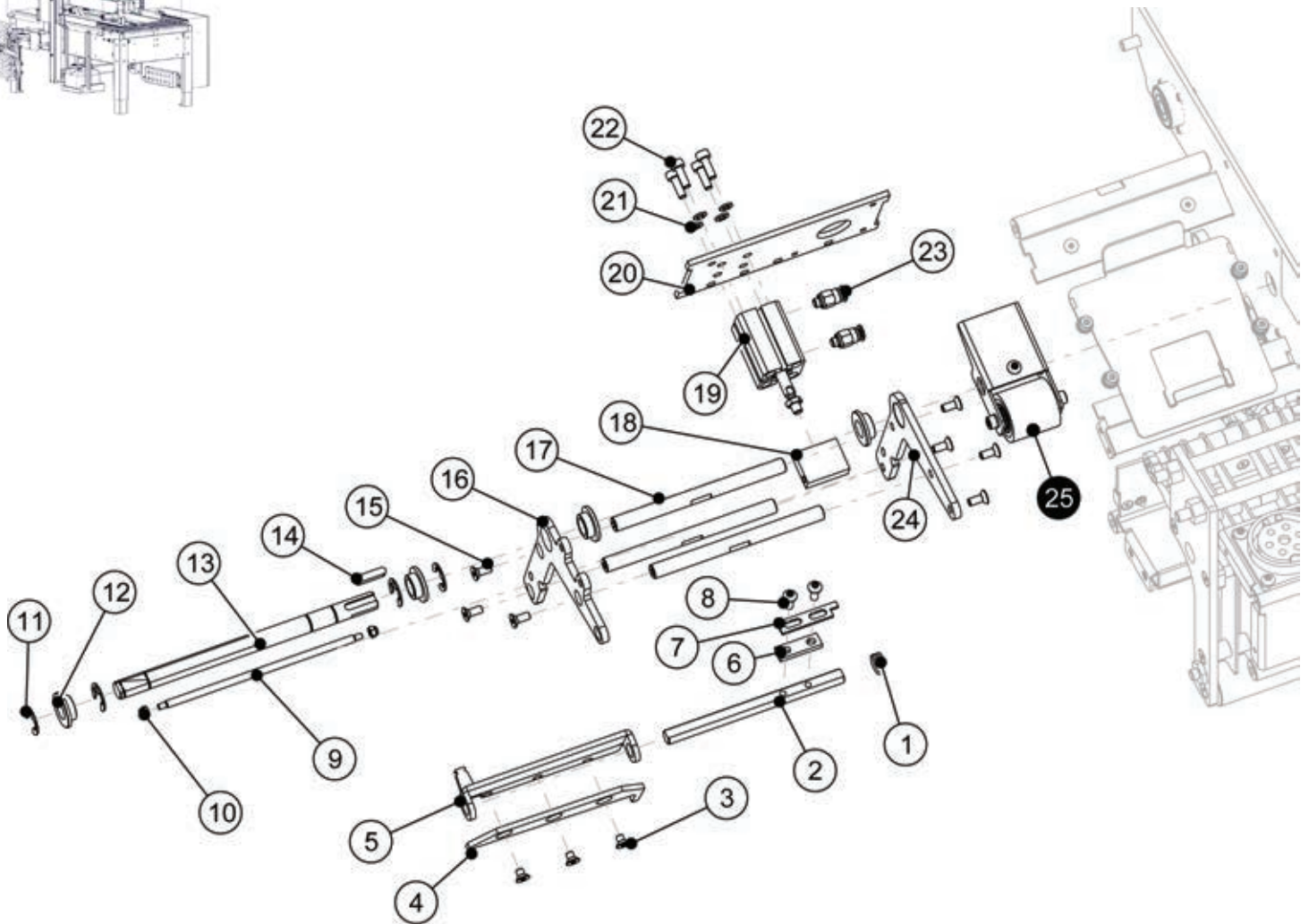
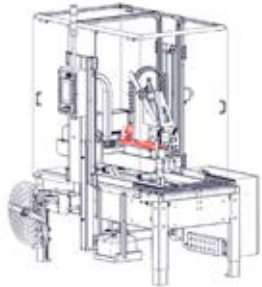


ITEM	PART NUMBER	DESCRIPTION	QTY
1	UF0189	E-RING 12mm	2
2	WET0262	DRIVE SHAFT	1
3	WET0354	DRIVE ROLLER	1
4	UF0248	KEY - M3 x 16mm	1
5	WET0247	WAT TAPEHEAD MOTOR	1
6	WET0188	GUIDE ROLLER	2
7	WET0189	ROLLER	1

ITEM	PART NUMBER	DESCRIPTION	QTY
8	WET0278	GUIDE ROLLER SHAFT	1
9	UF0248	KEY - M3 x 16mm	1
10	WST0113	ASSIST ROLLER	1
11	UF6413	SSS M4-0.7 x 12mm	1
12	UF0167	KEY - M4 x 25mm	1

# APPENDIX B

## Top Tapehead Cutting Assembly

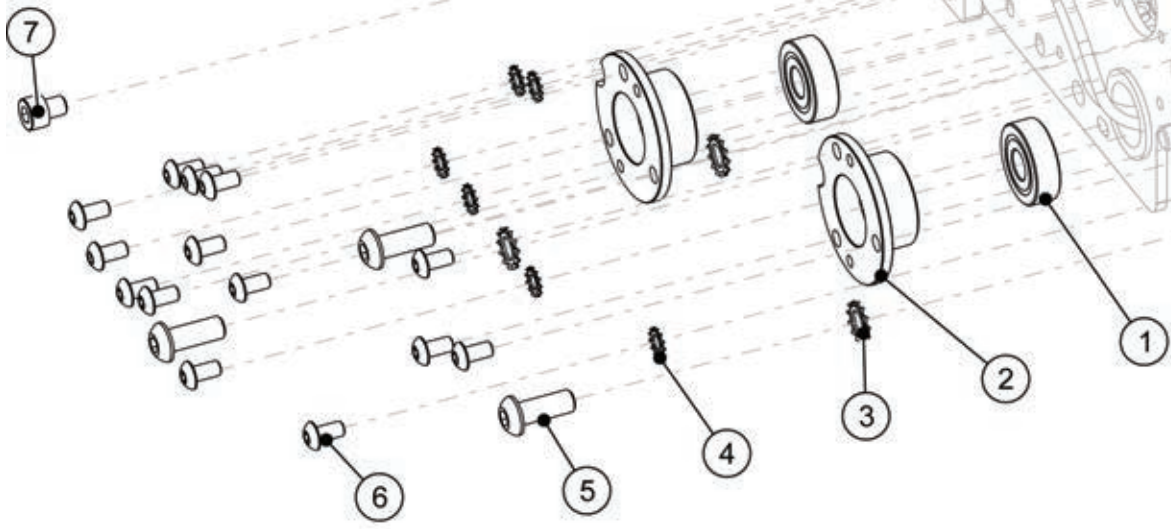
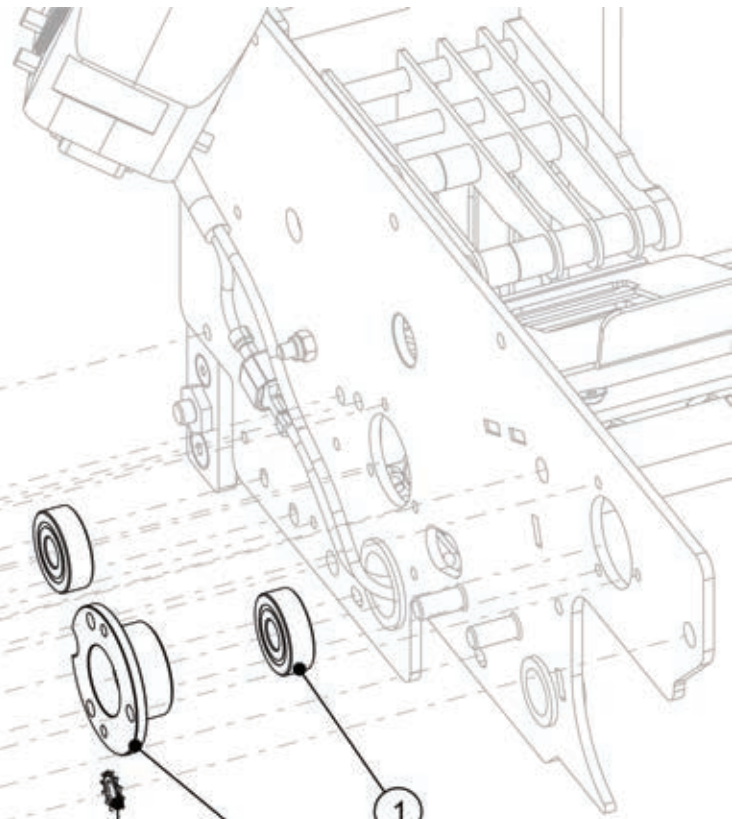
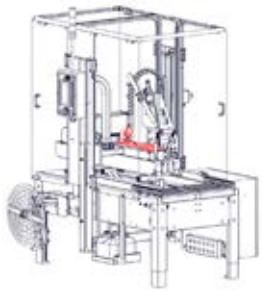


ITEM	PART NUMBER	DESCRIPTION	QTY
1	WET0347	TORSION SPRING	1
2	WET0265	KNIFE ARM TORSION SHAFT	1
3	UF6351	FHCS M4-0.7 x 6 mm	3
4	WPT0050	WT CUTTER BLADE	1
5	WPT0049	WT CUTTER BLADE SUPPORT	1
6	WET0268	TORSION SPRING STOP SPACER	1
7	WET0269	TORSION SPRING STOP	1
8	UF6364	BHCS M4 x 0.7 x 10mm	2
9	WET0277	SOLENOID COUPLING PIN	1
10	UF0165	LOCK NUT M3	2
11	UF7019	RETAINING RING	4
12	WPT0004	OILITE FLANGE BEARING 10mm	4
13	WET0276	PINCH ROLLER PIVOT SHAFT	1

ITEM	PART NUMBER	DESCRIPTION	QTY
14	UF0172	KEY M4 x 18mm	1
15	UF4514	FHCS M4-0.7 x 10mm	7
16	WET0267	LEFT KNIFE ARM	1
17	WET0266	KNIFE ARM CROSS SHAFT	3
18	WET0373	CUTTER YOKE	1
19	WET0375	CYLINDER 12mm x 20mm	1
20	WET0274	SOLENOID MOUNT	1
21	UF3749	LW M4	4
22	UF3801	SHCS M4-0.7 x 12mm	4
23	UPH4906	STRAIGHT FITTING	2
24	WET0264	RIGHT KNIFE ARM	1
25	WST0073	PINCH ROLLER ASSEM	1

# APPENDIX B

## Top Tapehead Left Hardware 2

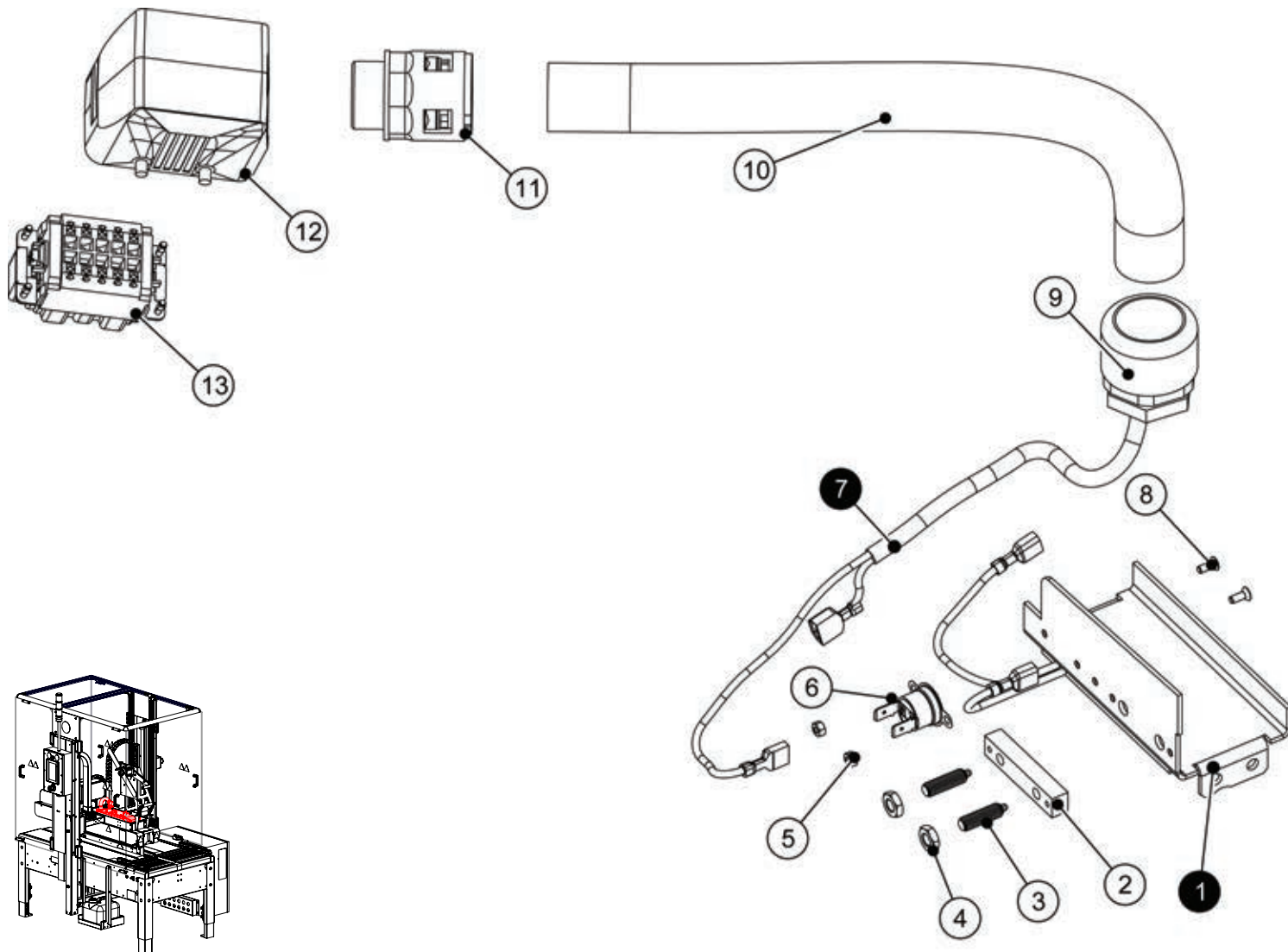


ITEM	PART NUMBER	DESCRIPTION	QTY
1	WET0341	BALL BEARING	2
2	WET0253	BEARING MOUNT	2
3	UF0168	EXTERNAL TOOTH LW M6	3
4	UF0166	EXTERNAL TOOTH LW M4	6

ITEM	PART NUMBER	DESCRIPTION	QTY
5	UF6414	BHCS M6-1 x 16mm	3
6	UF7009	BHCS M4-0.7 x 8mm	14
7	UF3149	SHCS M5-0.8 x 6mm	1

# APPENDIX B

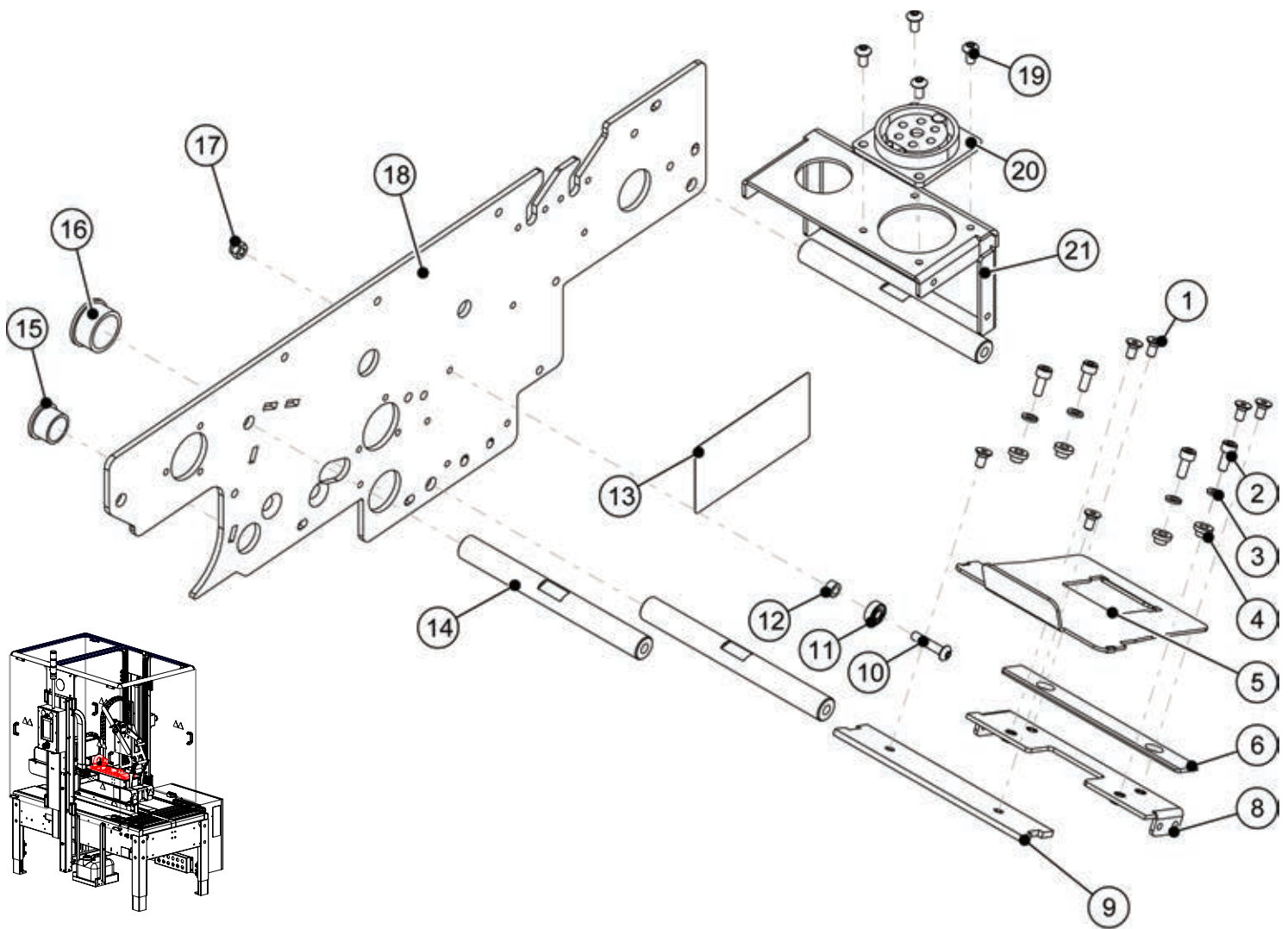
## Top Tapehead Electrical Assembly



ITEM	PART NUMBER	DESCRIPTION	QTY
1	WST0119	HEATER ASSEM 24V	1
2	WET0260	SPRING PLUNGER MOUNT	1
3	WET0342	LONG-NOSE SPRING PLUNGER	2
4	UF3361	JAM NUT M6	2
5	UF3717	HEX NUT M3-0.5	2
6	WET0185	THERMOSTAT	1
7	WET0403	TOP TAPEHEAD WIRE HARNESS	1
8	UF6350	FHCS M3-0.5 x 8 mm	2
9	WET0241	CORD GRIP	1
10	UPM6231	CORD	1
11	UPM4905	CORD GRIP	1
12	WET0382	10 POS HEAVY DUTY HOUSING	1
13	WET0381	10 POS HEAVY DUTY PLUG	1

# APPENDIX B

## Top Tapehead Frames

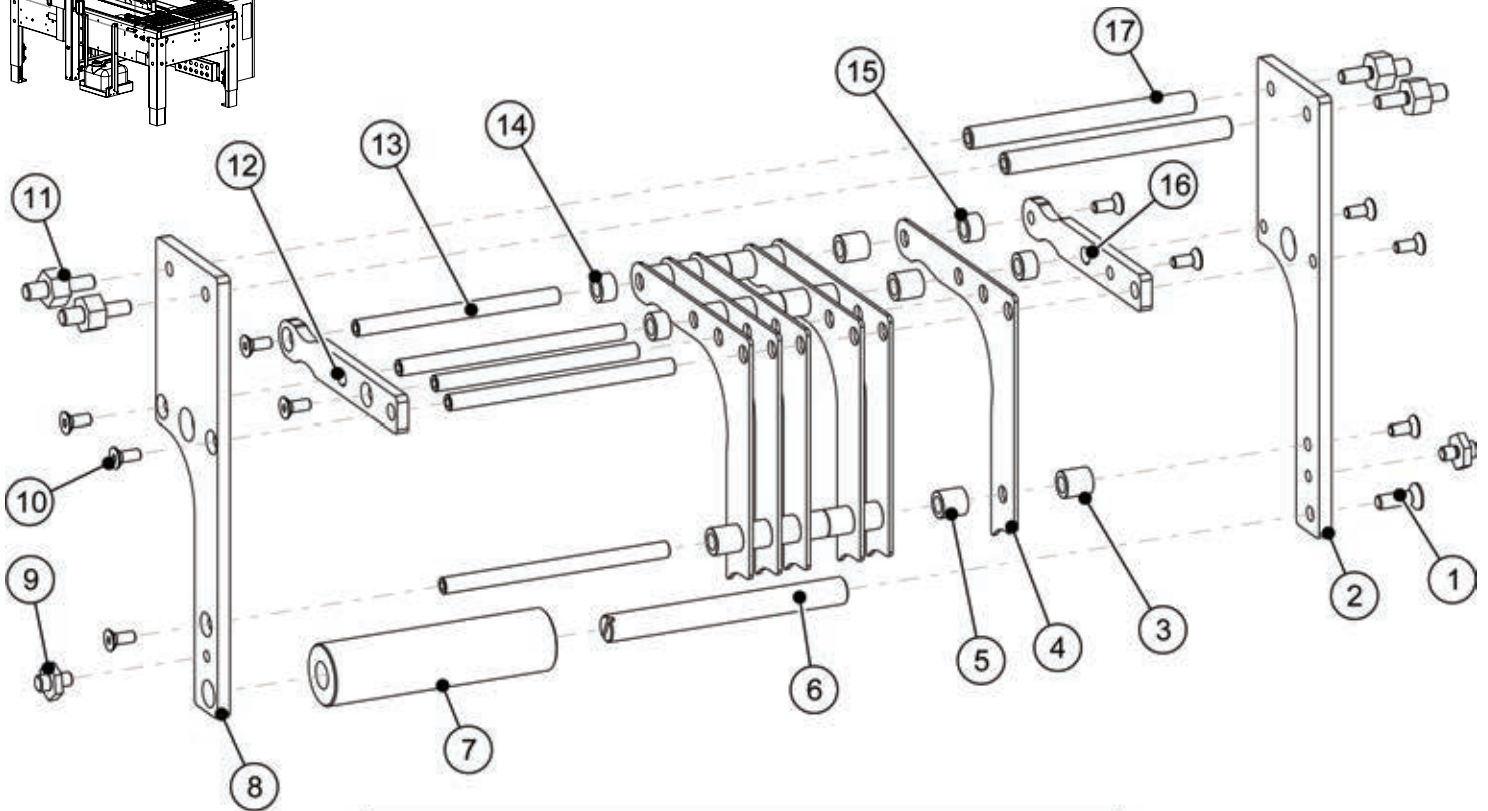
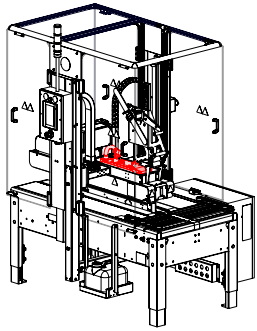


ITEM	PART NUMBER	DESCRIPTION	QTY
1	UF3274	FHCS M4-0.7 x 8mm	6
2	UF3759	SHCS M4-0.7 x 10mm	4
3	UF3749	LW M4	4
4	WET0272	TAPE HOLD DOWN RETAINER	4
5	WET0273	TAPE HOLD DOWN	1
6	WPT0044	STRIKER PLATE	1
8	WET0353	TAPE GUIDE SUPPORT	1
9	WET0270	REAR TAPE GUIDE SUPPORT	1
10	UF4050EV	BHCS M4-0.7 x 20mm	1
11	UPH1501	BALL BEARING	1
12	UPH1502	SPACER, dia 7, 4L	1

ITEM	PART NUMBER	DESCRIPTION	QTY
13	UPM8174	BLADE HAZARD LABEL	1
14	WET0256	CROSS BRACE SHAFT	3
15	WET0405	BUSHING SB-16	1
16	WET0346	BUSHING SB-22	1
17	UF6376	LOCKNUT M4	1
18	WET0310	TOP LEFT FRAME PLATE	1
19	UF7009	BHCS M4-0.7 x 8mm	4
20	UPM6879	6 TUBE SOCKET	1
21	WET0404	TOP TAPHEAD FRONT COVER	1

# APPENDIX B

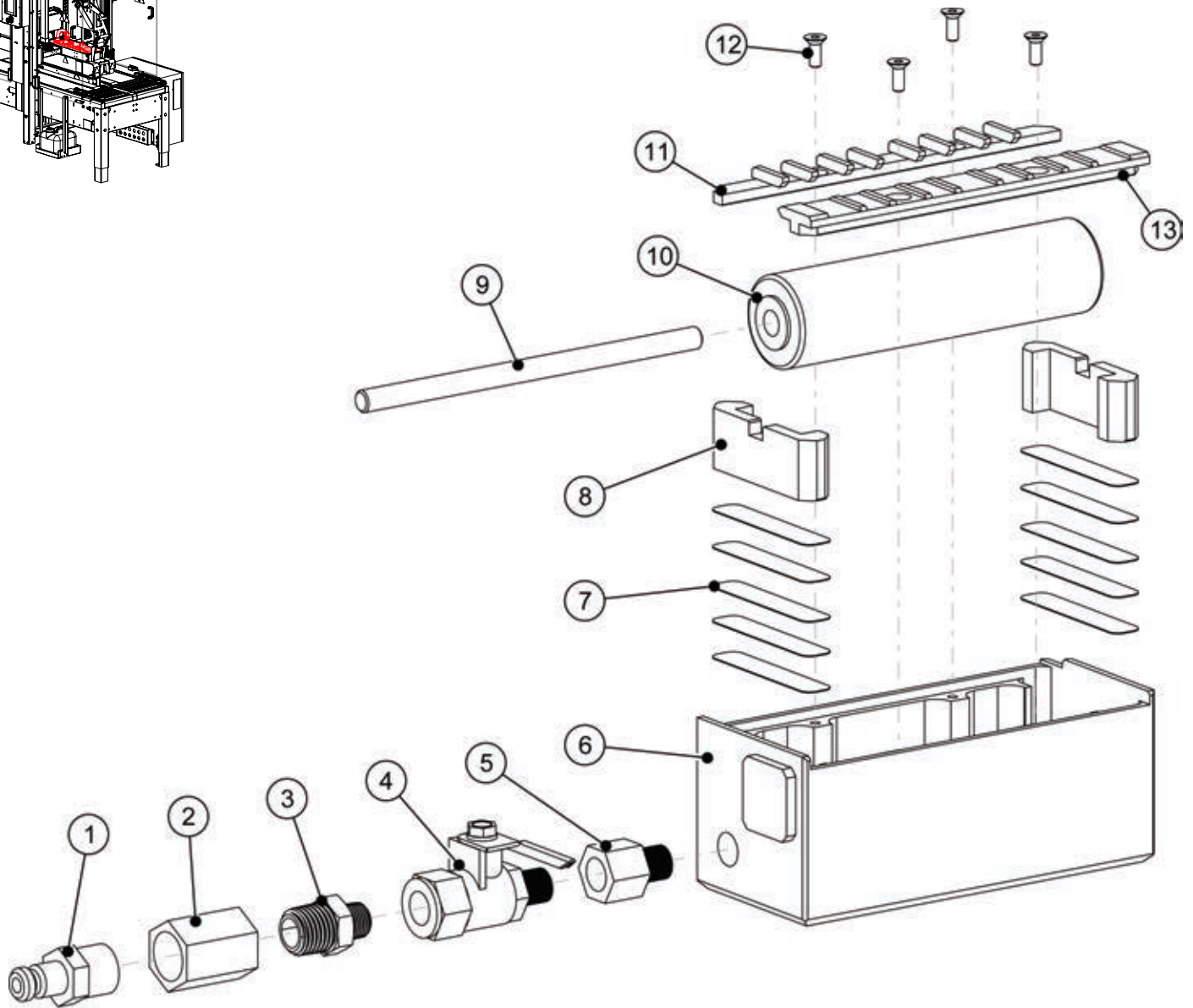
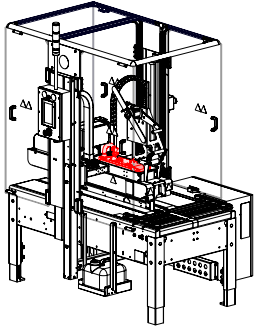
## Top Tape Chute



ITEM	PART NUMBER	DESCRIPTION	QTY
1	UF3277	FHCS M5-0.8 x 16 mm	1
2	WET0328	TOP OUTER TAPE CHUTE FRAME L	1
3	WET0377	SPACER, DIA 10, 10.5L	1
4	WET033	TOP OUTER TAPE CHUTE GUIDE	6
5	WET0180	SPACER, dia 10, 10L	18
6	WET0292	TAPE CHUTE ROLLER SHAFT	1
7	WET0376	TOP TAPE CHUTE ROLLER	1
8	WET0327	TOP OUTER TAPE CHUTE FRAME R	1
9	WET0295	GUIDE PIN	2
10	UF4514	FHCS M4-0.7 X 10mm	10
11	WET0191	HEX ADAPTER	4
12	WET0330	TOP OUTER TAPE CHUTE FRAME EXT	1
13	WET017	SHAFT, dia 6,	5
14	WET0181	SPACER, dia 10, 6L	2
15	WET0181	SPACER, dia 10, 6L	2
16	WET0330	TOP OUTER TAPE CHUTE FRAME EXT	1
17	WET0225	SHAFT, 90L	2

# APPENDIX B

## Top Water Pot

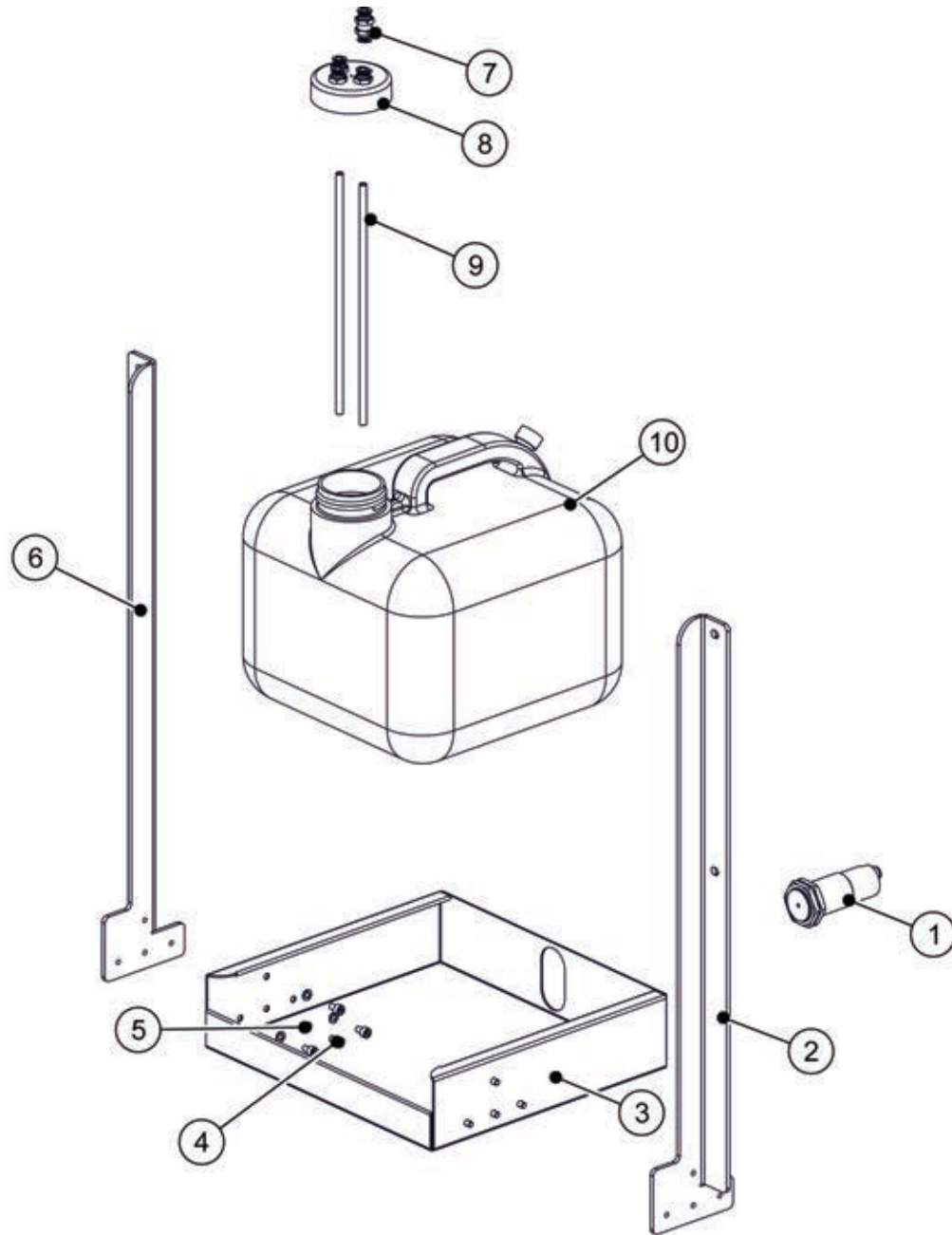
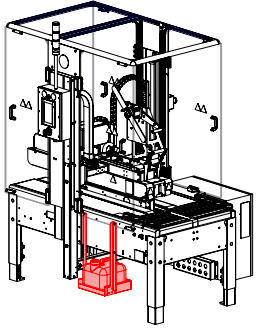


ITEM	PART NUMBER	DESCRIPTION	QTY
1	UPH1500	QUICK COUPLING PLUG	1
2	UPH1499	REDUCER	1
3	WET0385	REDUCER	1
4	UPH1497	BALL VALVE	1
5	UPH1496	REDUCER	1
6	WET0301	WATER POT BASE	1
7	WET0359	WATER POT SHIM	10

ITEM	PART NUMBER	DESCRIPTION	QTY
8	WET0302	WATER POT INSERT	2
9	WET0207	SHAFT, 6mm	1
10	WET0071	ROLLER	1
11	WET0303	WATER POT FRONT GUIDE	1
12	UF6350	FHCS M3-0.5 x 8mm	4
13	WET0304	WATER POT REAR GUIDE	1

# APPENDIX B

## Water Supply Assembly

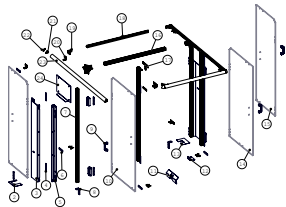


ITEM	PART NUMBER	DESCRIPTION	QTY
1	UPM8171	WATER SENSOR (OPTIONAL)	1
2	UPM8169	BRACKET CARBOY RIGHT	1
3	UPM8165	CARBOY SHELF WEDGE	1
4	UF7029	SHCS M5-0.8 x 12mm	8
5	UF7023	LW M5	8
6	UPM8166	BRACKET CARBOY LEFT	1

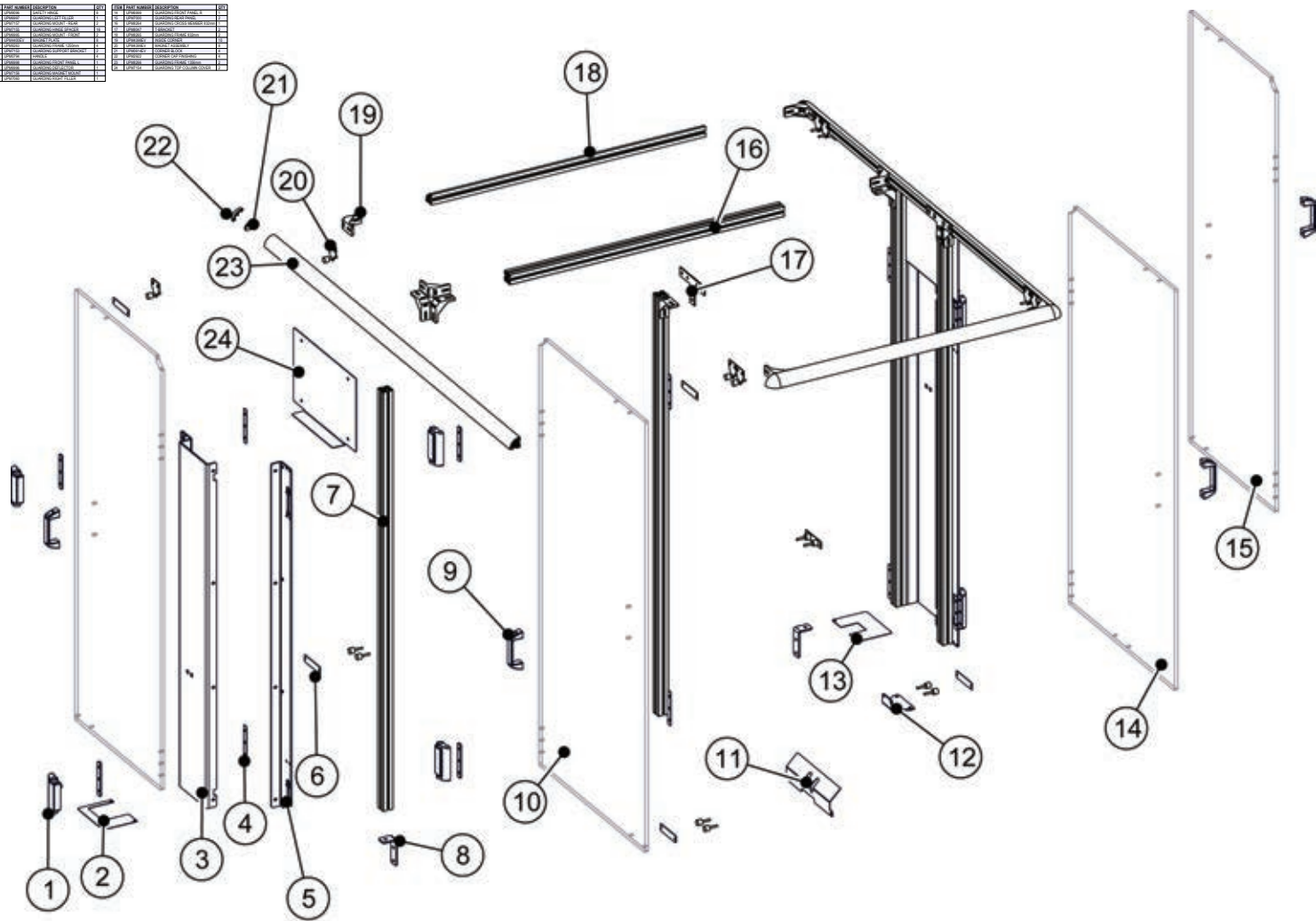
ITEM	PART NUMBER	DESCRIPTION	QTY
7	UPM8170	BULKHEAD PUSH-IN FITTING	4
8	UPM8163	CARBOY LID	1
9	UPM8164	CARBOY DIP TUBE	2
10	UPM8172	CARBOY	1

# APPENDIX B

## Guarding



ITEM	PART NUMBER	DESCRIPTION	QTY
1	UPM8096	SAFETY HINGE	8
2	UPM6997	GUARDING LEFT FILLER	1
3	UPM7157	GUARDING MOUNT - REAR	2
4	UPM7155	GUARDING HINGE SPACER	16
5	UPM6995	GUARDING MOUNT - FRONT	2
6	UPM4400EV	MAGNET PLATE	8
7	UPM8263	GUARDING FRAME 1250mm	4
8	UPM7153	GUARDING SUPPORT BRACKET	2
9	UPM0794	HANDLE	4
10	UPM6998	GUARDING FRONT PANEL L	1
11	UPM6996	GUARDING DEFLECTOR	1
12	UPM7156	GUARDING MAGNET MOUNT	1
13	UPM7060	GUARDING RIGHT FILLER	1
14	UPM6999	GUARDING FRONT PANEL R	1
15	UPM7000	GUARDING REAR PANEL	2
16	UPM8264	GUARDING CROSS MEMBER 832mm	1
17	UPM8047	T-BRACKET	2
18	UPM8265	GUARDING FRAME 832mm	2
19	UPM4398EV	INSIDE CORNER	10
20	UPM4399EV	MAGNET ASSEMBLY	8
21	UPM0614EV	CORNER BLOCK	4
22	UPM2922	CORNER CAP FINISHING	4
23	UPM8266	GUARDING FRAME 1356mm	2
24	UPM7154	GUARDING TOP COLUMN COVER	2



ITEM	PART NUMBER	DESCRIPTION	QTY
1	UPM8096	SAFETY HINGE	8
2	UPM6997	GUARDING LEFT FILLER	1
3	UPM7157	GUARDING MOUNT - REAR	2
4	UPM7155	GUARDING HINGE SPACER	16
5	UPM6995	GUARDING MOUNT - FRONT	2
6	UPM4400EV	MAGNET PLATE	8
7	UPM8263	GUARDING FRAME 1250mm	4
8	UPM7153	GUARDING SUPPORT BRACKET	2
9	UPM0794	HANDLE	4
10	UPM6998	GUARDING FRONT PANEL L	1
11	UPM6996	GUARDING DEFLECTOR	1
12	UPM7156	GUARDING MAGNET MOUNT	1
13	UPM7060	GUARDING RIGHT FILLER	1

ITEM	PART NUMBER	DESCRIPTION	QTY
14	UPM6999	GUARDING FRONT PANEL R	1
15	UPM7000	GUARDING REAR PANEL	2
16	UPM8264	GUARDING CROSS MEMBER 832mm	1
17	UPM8047	T-BRACKET	2
18	UPM8265	GUARDING FRAME 832mm	2
19	UPM4398EV	INSIDE CORNER	10
20	UPM4399EV	MAGNET ASSEMBLY	8
21	UPM0614EV	CORNER BLOCK	4
22	UPM2922	CORNER CAP FINISHING	4
23	UPM8266	GUARDING FRAME 1356mm	2
24	UPM7154	GUARDING TOP COLUMN COVER	2

